

TIFFIN MOTORHOMES, INC.

105 2nd Street NW ♦ Red Bay, Alabama 35582 U.S.A.

2020 PowerGlide® Owner's Manual



WARNING: Breathing diesel engine exhaust exposes you to chemicals known to the State of California to cause cancer and birth defects or other reproductive harm.

- Always start and operate the engine in a well-ventilated area.
- If in an enclosed area, vent the exhaust to the outside.
- Do not modify or tamper with the exhaust system.
- Do not idle the engine except as necessary.

For more information go to www.P65warnings.ca.gov/diesel.

TIFFIN MOTORHOMES, INC.

Red 340 Chassis Owner's Manual

© Tiffin Motorhomes, Inc.
105 2nd Street NW, Red Bay, AL 35582 U.S.A.
Telephone 256.356.8661 • Facsimile 256.356.8219
E-Mail: info@tiffinmotorhomes.com

DISCLAIMER

Many of the features and appliances described in this manual may or may not be reflected in the actual motor home purchased, depending on the options and models selected by the motorhome owner. All items, materials, instructions, and guidance described in this manual are as accurate as possible at the time of printing. However, because of Tiffin Motorhomes' ongoing and dedicated commitment to excellence, improvement of Tiffin motorhomes is a continuing process. Consequently, Tiffin Motorhomes reserves the right to make substitutions and improvements in its makes and models of motorhomes without prior notification. Substitutions of comparable or better materials, finishes, appliances, instrumentation, and instruction may be made at any time it is deemed prudent to provide the customer with the best possible motorhome meeting the customer's requirements.

Copyright © 2019 by Tiffin Motorhomes, Inc. -- all rights reserved

Printed in the United States of America: Sixth U.S. Printing: March, 2019

[20190301]

**Allegro Red 340 Tiffin PowerGlide Chassis
Customer Support
256-356-0261
Monday-Friday
6 a.m. - 4:30 p.m. CST**

If you should require chassis service, *you should first contact your nearest Tiffin Powerglide® Chassis service center.* If for some reason this is not possible or if you would like to call the manufacturers direct, you can contact them at the following telephone numbers:

TIFFIN POWERGLIDE CHASSIS

256-356-0261

(Please have your VIN# ready)

COACH-NET

(Nights and weekends)

1-866-590-5937

CUMMINS ENGINE COMPANY

1-800-DIESELS (800-343-7357)

ALLISON TRANSMISSIONS

1-800-524-2303

MICHELIN TIRE

800-TIRE-HELP (800-847-3435)

Visit our website at www.tiffinmotorhomes.com

Table of Contents

Chapter 1		Engine Shutdown	4-14
Tire Care		Diagnostic Fault Codes	4-15
Tire Care	1-2	Towing Hitch	4-15
Correct Tire Pressure	1-3		
Chapter 2		Chapter 5	
Allison Transmission Operation		Scheduled Maintenance	
Driving Considerations	2-2	Scheduled Maintenance Chart	5-2
Fluid Level Check	2-4	Fluids	5-5
		Lubrication Points	5-8
		Maintenance Parts	5-13
		Tiffin Assistance	5-14
Chapter 3		Chapter 6	
Brake System		Pre-Trip Inspection	
Brake System	3-2	Pre-Trip Inspection	6-2
Compressed Air System	3-4		
Air Dryer	3-6		
Engine Brake	3-7		
Chapter 4		Chapter 7	
Cummins Engine		Instruments & Controls	
EPA Mandates	4-3	Tiffin Instrument Panel	7-2
ATS Warning Lamps	4-4	Driver's Information Center	7-5
DPF Maintenance	4-4	Trip Reset and Average Fuel Economy	7-9
Aftertreatment Operation	4-5	Modes of Operation	7-10
Engine Indicator Lamps	4-7		
Engine Starting	4-11	Chapter 8	
Cold-Weather Starting	4-12	Air Supply	
Engine Braking (optional)	4-12	Air Supply	8-2
Cruise Control	4-13		

Chapter 9

Warranty

Chassis Warranties 10-2

Chapter 10

Allegro Club

Allegro Club Information 11-2

TIRE CARE

TIRE CARE

- What is the most important component of tire care?

- ✓ TIRE PRESSURE

- Why?
 - ✓ Improved Ride
 - ✓ Improved Tire Wear
 - ✓ Improved Road Handling
 - ✓ Improved Braking



Tire Care

Maintaining the proper tire inflation pressure is the most important thing you can do to maximize the life of your tires. An under-inflated tire can build up excessive heat that may go beyond the prescribed limits of endurance of the rubber and the radial cords. Over-inflation will reduce the tire's footprint on the road, reducing the traction, braking capacity, and handling of your vehicle. An over-inflated tire will also cause a harsh ride, uneven tire wear, and will be more susceptible to impact damage.

Keep in mind that the pressure rating on the side wall of your tire is the *maximum* pressure for that tire. This is not necessarily the *correct* pressure for the tires when installed on *your* vehicle. Maintaining the correct tire pressure for *your vehicle's loaded weight* is extremely important and must be a part of regular vehicle maintenance.

Correct Tire Pressure

- How to determine the correct pressure
 - ✓ Weigh each wheel position
 - ✓ Set tire pressure according to chart



* This Chart Shows Cold Inflation Pressures

255/80 R22.5 LRG - XRV

Load per Wheel-end
22.5 X 9.00" Wheel

		PSI=>									Max Load per Tire
		70	75	80	85	90	95	100	105	110	
		KPA=>									
		480	520	550	590	620	660	690	720	760	
Single	LBS	3,875	4,070	4,300	4,440	4,620	4,805	4,975	5,150	5,205	5,205
Dual	LBS	7,050	7410	7,720	8,080	8,410	8,820	9,050	9,370	9,610	4,805
Single	KG	1,760	1,850	1,950	2,010	2,100	2,180	2,260	2,340	2,360	2,360
Dual	KG	3,200	3,360	3,500	3,660	3,820	4,000	4,100	4,260	4,360	2,180

TIRE CARE

To determine the correct air pressure for your tires, load your motor home as you would normally travel, including water and fuel. Go to a truck scale as found at most major truck stops and weigh **each wheel position** independently, with driver and passenger(s) in the vehicle as described in the *Michelin Recreational Vehicle Tire Guide* (MWL43146 Rev. 03/12) to determine the correct air pressure for the weight on each wheel position. Then use the charts in the guide and adjust the pressure accordingly when the tires are cool or have not been driven for more than one mile. You may call 1-800-847-3435 for a copy of the *Michelin Recreational Vehicle Tire Guide*.

NOTE: Never reduce the air pressure in a hot tire.

REMEMBER: For control of your RV, it is critical that the tire pressure be the same on both sides of the axle.

Emissions and Fuel Efficiency Compliance

Your chassis was designed, and built, with components including, but not limited to, low rolling resistance tires specifically designed and manufactured to exacting standards for regulatory fuel efficiency and greenhouse gas emissions compliance. The vehicle owner is responsible for being sure these components are replaced with the same or equivalent components that maintain compliance with federal and local regulations.

For help with determining tires that are the same or equal in regards to rolling resistance for maintaining compliance with the regulatory standards, please contact Michelin at 1-800-947-3435.

Allison Transmission Operation

Operation

The Allegro Red 340 with the Powerglide Chassis is equipped with an Allison 2500MH transmission.

The display screen on the shift control pad will indicate the highest selected gear for the transmission. When mountainous or up-and-down terrain conditions are encountered, you should **manually select a lower gear**, preferably lower than 5th gear. This can be done at any road speed by pressing the down arrow repeatedly until the desired gear is indicated in the window of the shifter pad. When your road speed decreases to a safe point, the transmission will downshift at a higher **RPM** than normal. This will decrease the use of overdrive while pulling hills, which can result in excessive heat build-up in the transmission, and keeps the engine operating at peak horse power and performance.

When ascending a grade, maintain engine speed to within **400-500 RPM** of governed engine speed. Governed speed will be **2800 RPM** on the Cummins ISB engine model. Road speed may decrease, but the engine will be at its peak in the power curve.

It is especially pertinent to monitor your water temperature gauge when climbing steep grades. Keep in mind that it is not uncommon for the temperature to increase, especially in hot weather. If the gauge reaches 225°F or if the temperature warning light on the gauge panel should come on, reduce your road speed, shift to the next lower gear and keep your tachometer within **500 RPM** of engine governed speed. In many cases this will stabilize the water temperature. If the temperature gauge continues to rise, or if the stop engine light comes on, pull to the side of the road and shift the transmission into neutral. Bring the engine **RPM** to **1,700—2,000 RPM** until the temperature drops down into the normal range. This should occur in a relatively short period of time. If the temperature gauge does not begin to drop, stays in the red zone, or continues to rise, shut down the engine and allow it to cool. After the engine is allowed to cool check the fluid level in the reservoir and add coolant if needed.

A good “**rule of thumb**” for descending grades is to never use a higher gear than was used to climb the same or similar grade. Try to keep the engine within **500 RPM** of governed speed. This will give the best engine braking and reduce the need to use the service brakes. Select a gear that will keep you at a safe speed with minimal brake application. Never ride your brakes when descending a grade since excessive brake heat will build up and your brakes could fade, leaving you with little or no braking power.

Your vehicle is equipped with an engine brake. The engine brake will assist in slowing your vehicle on a downhill grade. With the engine brake switch in the on position, release the accelerator and depress the service brake to activate the engine brake. When the engine brake is activated the transmission will pre-select a lower gear to aid in braking. This is indicated by a “2” in the left hand pane of the transmission shift selector. The transmission will begin to down-shift as soon as the road and engine speed will safely allow. This will produce a slowing effect and will remain engaged until either the exhaust brake switch is turned off, the accelerator is pressed, or the engine speed drops to 800 RPM. If your initial speed is high, you may have to step on the brake to slow the vehicle before the transmission will down-shift from 6th gear to 5th gear. This is normal.

Always select (**N**) neutral on the transmission shift pad prior to turning off the vehicle engine.

Mode Button

The mode button is located on the keypad pushbutton shift selector. The mode button can be pressed at any time after engine start to activate the alternate shift schedule. There are two shift schedules, a primary and a secondary.

The primary shift schedule is normally used each time the vehicle is started and is specified in such a way to accommodate **“NORMAL”** vehicle operation. This shift schedule is also known as **“PERFORMANCE”** mode.

The secondary shift schedule is an alternate shift schedule that the TCM only uses upon request. This shift schedule is also known as **“ECONOMY”** mode.

“ECONOMY” mode will allow the transmission to make shift changes at a lower engine RPM, thus making it possible to get better fuel mileage. Factors such as terrain, driving habits, vehicle weight and towing will still have an impact on mileage.

Fluid Level Check

Use the transmission dipstick for best results in checking the transmission fluid level. The transmission will not reach operating temperature until the coach has been driven for at least 15 miles. Therefore, it may be best to check transmission fluid level at the end of your driving day.

Transmissions **do not** consume fluid. If your transmission shows to be low of fluid, it should be inspected for leaks.

The dipstick is marked with temperature bands for a COLD and HOT fluid level check. The fluid check marked COLD is designed to allow the fluid level to be checked from 61-140°F (16-60°C). The fluid check marked HOT is designed to allow the fluid level to be checked from 160-220°F (71-104°C).

Check the transmission fluid level with the following steps (**HOT CHECK PROCEDURE**):

Conditions that must be met for checking transmission fluid with the dipstick:

- Be sure transmission is at operating temperature (104° to 220° F)
- Vehicle is parked on level ground with the parking brake is set
- Transmission in neutral and park brake applied
- Engine is at low idle
- Wait until vehicle has been stationary for two minutes
- With the engine running, remove the dipstick from the tube and wipe the dipstick clean
- Insert the dipstick into the tube and remove. Check the fluid level reading. Repeat the check procedure to verify the reading.

Brake System

Brake System

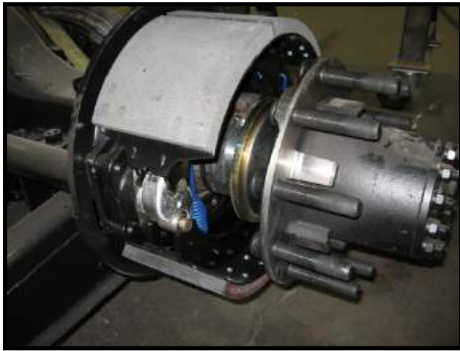

Figure 3-1: Rear Brakes

- Front brakes are air applied disc
- Rear brakes (Figure 3-1) double as parking brake
 - Park brakes are spring applied – air released
 - Two large drum brakes
 - Park brake remains applied even if air pressure is lost
- If air pressure is lost
 - A buzzer and warning lamp will alert you
- Chassis is equipped with automatic slack adjusters (Figure 3-2)
 - No brake adjustment required



Figure 3-2: Automatic Slack Adjuster

The rear brakes on the PowerGlide chassis are also used as the parking brakes. This provides you the holding power of two large drum brakes to prevent your coach from rolling, even when fully loaded on a 20% grade.

A decrease in air pressure while driving will **not** cause an immediate loss of brakes. If a significant leak develops in the air system, at approximately **60 PSI** you will be alerted by a lamp on the instrument panel, and by an audible alarm. As you apply the brakes, the air supply holding the park brakes in the released position will gradually be depleted. When system pressure drops to approximately **40 PSI** the rear brakes will set. This allows you sufficient time to pull over to the side of the road.

B R A K E S Y S T E M

NOTE: The rear brakes have dual chambers – one for the service brakes and one for the park brake. The service brakes are air applied and spring released. The park brake is spring applied and air released.

The brake system is equipped with automatic slack adjusters that avoid the need to manually adjust your brakes. Each time you step on the brake pedal, if adjustment is needed, the adjusters will take up the slack.

Compressed Air System



BRAKE SYSTEM



Compressed Air System

The compressed air system is comprised of **multi-air storage tanks**. The **primary tank** stores and supplies air for the **rear brakes**, the secondary tank stores and supplies air for the **front brakes**.

When air is compressed it becomes hot. As it cools, condensed moisture forms in the system. The air system is equipped with an air dryer to remove most of this moisture. The dryer has an automatic moisture ejector that releases the trapped moisture back into the atmosphere. However, some moisture will form in the system beyond the dryer, and make its way into the storage tanks. As moisture collects in the **primary** and **secondary** tanks, it displaces the area needed for air storage, thus requiring that the tanks be **drained periodically**.

The air system is equipped with **air tank drains** conveniently located in the compartment with the DEF tank. Each drain is attached to a different tank. These drains should be **opened regularly** for a few seconds to **remove** any moisture trapped in the tanks.

Air Dryer



Figure 3-3: Haldex Purest Air Dryer

The Tiffin PowerGlide chassis air brake system features a Haldex Purest air dryer (Figure 3-3), which removes the condensed moisture from compressed air. The air dryer is equipped with a desiccant cartridge that needs to be changed **every 36 months**. The dryer is located on the driver's side (LH) frame rail (behind the rear axle).

Warning

Air tanks should be bled of all pressure any time you perform work on the air system.

Engine Brake



Exhaust Brakes cannot be used on ISB engines with common rail fuel systems. The variable geometry turbocharger (VGT) takes the place of the exhaust brake and requires no maintenance. The VGT works in conjunction with the engine and transmission to provide an integrated braking system used to help slow the vehicle. This braking power is achieved by modulating the turbo sliding nozzle ring to restrict the flow of exhaust gases from the engine, which in turn creates a high back pressure on the engine. The high back pressure creates a high level of resistance to the motion of the pistons within the engine and this resistance is used to reduce engine speed and thus vehicle speed. The engine brake feature will only function when the driver turns the exhaust brake switch to the on position. Once the switch is in the on position and the vehicle is moving faster than 8 k/h (5 MPH); the exhaust brake will operate when the driver removes pressure from the throttle pedal allowing the engine to see 0% throttle and 0% fuel delivery and taps the service brake. Engine braking is most effective when the engine RPM is higher. The automatic transmission has been programmed to downshift more aggressively when the exhaust brake is enabled to increase brake performance.

As mentioned above:

The engine brake is activated when the following conditions are satisfied:

1. The engine brake switch is in the “ON” position
2. The accelerator pedal is released
3. The vehicle is moving faster than 8 k/h (5 mph)
4. The service brake is depressed momentarily

Cummins ISB Engine

Engine Model
ISB6.7 340

Advertised HP (kW) @ RPM
340 (254) @ 2600

Peak Torque LB-FT (N•M) @ RPM
700 (949) @ 1600



EPA Mandates

The Environmental Protection Agency (EPA) mandates that all engines built after December 31, 2009 must reduce the level of emissions exhausted by the engine to the following levels.

Nitrous Oxides (NO_x) – 0.2 g/bhp-hr

Particulate Matter (PM)- .01 g/bhp-hr

To meet EPA guidelines, diesel engines installed in Tiffin Motorhomes PowerGlide chassis for domicile in Canada and the USA use an after treatment system (ATS) with a diesel particulate filter (DPF) to reduce particulate matter, and selective catalytic reduction (SCR) technology to reduce NO_x downstream of the engine.

Notice

Using non-specification fluids can result in serious damage to the ATS. It is extremely important that the following guidelines be met for vehicles with EPA10 thru EPA2017 compliant engines, or damage may occur to the ATS, and the warranty may be compromised.

- Use "ultra-low sulfur diesel (ULSD)" with 15 ppm sulfur content or less.
- Do not use fuel blended with used engine lube oil or kerosene.
- Engine lube oil must have a sulfated ash level less than 1.0 wt %, currently referred to as CJ-4 oil.
- Use only API certified diesel exhaust fluid (DEF) in the DEF tank.

The ATS is comprised of a diesel oxidation catalyst (DOC), and a diesel particulate filter (DPF). The DPF traps soot particles, and exhaust heat converts the soot to ash in the DPF in a process called regeneration (re-gen). The harder an engine works, the better it disposes of soot. When the engine is running under load and re-gen occurs without input, it is called passive re-gen. If the engine isn't running hot enough, the electronic controls may initiate an active re-gen, whereby extra fuel is injected into the exhaust stream before the DPF, to superheat the soot trapped in the filter and burn it to ash. Both types of re-gen occur without driver input.

Operating at reduced engine load will allow soot to accumulate in the DPF. When this occurs, the DPF lamp  illuminates, indicating that a re-gen **must** be performed, and the driver **must** bring the vehicle up to highway speed to increase the load. Driving at highway speeds for 20 minutes should allow for a re-gen to take place, and turn off the DPF lamp.

After the exhaust stream passes through the DPF, it flows through a second canister housing which is the SCR device. A controlled quantity of diesel exhaust fluid (DEF) is injected into the exhaust stream where heat converts it to ammonia (NH₃) gas. This mixture flows through the SCR device where the ammonia

gas reacts with the NO_x in the exhaust to produce harmless nitrogen (N₂) and water vapor (H₂O), which then exits out of the tailpipe.

ATS Warning Lamps

Warning lamps in the driver's message center alert you of situations with the after-treatment system.

- An illuminated DPF lamp indicates a re-gen is needed.  Driving at highway speeds for 20 minutes should correct this condition.
 - A blinking DPF lamp indicates the need for a re-gen is more urgent. Again, driving the vehicle at highway speeds for 20 minutes should correct this condition.
 - A blinking DPF lamp along with a check engine light indicates that the engine is unable to effectively regenerate, and you should **immediately** seek service at the nearest Cummins Authorized Dealer.

- An illuminated High Exhaust Temperature (HEST) lamp alerts the operator of elevated exhaust temperatures while the engine is performing an active re-gen.  Do not operate, or park the vehicle near flammable objects while the HEST lamp is illuminated.

- An illuminated DEF warning lamp indicates that the DEF tank should be refilled at the next opportunity.  This light will illuminate when the tank level is at approximately 10%.
 - A blinking DEF warning lamp indicates the tank level has dropped to approximately 5%.
 - A blinking DEF lamp along with the check engine lamp indicates the tank level has dropped to approximately 2.5%. A 25% reduction in engine torque will be applied with this condition.
 - When the tank is empty the Stop Engine Light will be illuminated and the vehicle speed will be limited to 5 MPH. Filling the tank with new DEF will remedy this condition.

DPF Maintenance

Eventually ash will accumulate in the DPF and the filter will require servicing. DPF servicing must be performed by an authorized technician, following the engine manufacturer's instructions. DPF cleaning will be required at approximately 200,000 miles of service. A record must be maintained for warranty purposes, which includes:

- Date of cleaning or replacement
- Vehicle mileage
- Particulate filter part number and serial number

Aftertreatment Operation

Diesel Particulate Filter

Soot is composed of the partially burned particles of fuel that occur during normal engine operation (black smoke).

Ash is composed of the partially burned particles of engine oil that occur during normal engine operation.

Over time, both soot and ash accumulate in the DPF and must be removed. Soot is removed by a process called regeneration. Ash is removed by removing the DPF and cleaning it at specified intervals.

A vehicle with an ATS has up to four additional indicator lamps on the dashboard. These additional lamps, along with the check engine lamp, alert the operator of the status of the ATS.

Ultra low sulfur diesel fuel is required for an engine equipped with a DPF. If ultra low sulfur diesel is not used, the engine might not meet emissions regulations, and the DPF or DOC can be damaged.

To maximize the maintenance intervals of the DPF, Cummins Inc. recommends the use of a lubricating engine oil meeting Cummins Engineering Standard 20081. The use of oil meeting CES 20081 also requires the use of ultra low sulfur diesel fuel to maintain the specified oil drain interval without risk of engine damage.

Regeneration

Regeneration is the process of converting the soot collected in the DPF into ash.

Under some operating conditions, such as low speed, low load, or stop and go duty cycles, the engine may not have enough opportunity to regenerate the DPF during normal vehicle operation. When this occurs, the engine will illuminate the DPF lamp to inform the vehicle operator that assistance is required, typically in the form of operating the vehicle at highway speeds for approximately 20 minutes.

Heat is required for the regeneration process to occur. Regeneration can be classified into two different types: passive regeneration and active regeneration.

Passive Regeneration

Passive regeneration occurs when the exhaust temperatures are naturally high enough to oxidize the soot collected in the DPF faster than the soot is collected.

Passive regeneration typically occurs when the vehicle is driven at normal highway speeds and/or under heavy loads.

Active Regeneration

Active regeneration occurs when the exhaust temperatures are not naturally high enough to oxidize the soot in the DPF faster than it's collected.

Active regeneration requires assistance from the engine in to increase the exhaust temperature. This is typically accomplished by the engine injecting a small amount of diesel fuel into the exhaust stream, which is then oxidized by the DOC, and creates the heat needed to regenerate the DPF.

Active regeneration will occur more frequently in vehicles operated at low speed, low load, or stop and go duty cycles. Active regeneration only occurs if the engine ECM has detected that the DPF restriction has reached a specified limit, and may only occur if the vehicle is moving above a preset speed threshold. The engine ECM will activate and de-activate active regeneration as needed.

Active regeneration is largely transparent to the vehicle operator, the vehicle operator may notice an increase in turbocharger noise during an active regeneration event, and may notice that the high exhaust temperature lamp is illuminated, if the vehicle is so equipped.

During active regeneration, the exhaust temperature can be hotter than when the engine is operating at full load. The exhaust temperature during a normal active regeneration event could reach 1100°F, and possibly 1500°F under certain conditions.

Warning

Active regeneration can occur any time the vehicle is moving, and the exhaust temperature can remain hot after the vehicle has stopped moving. The exhaust temperature could reach 1500°F, which is hot enough to ignite or melt common materials, or to burn people. If the HEST lamp is illuminated do not operate or park the vehicle with the exhaust near people, or flammable materials.

Aftertreatment Warm-up

The ATS warm up function is used to help prevent the buildup of water condensation in the ATS during extended idle operation.

After approximately four hours of engine idle operation, the engine speed will increase to around 1100 RPM, and remain at this speed for 10 minutes. During this time the ATS is warmed up enough to evaporate any water that has condensed in the system.

The ATS warm-up function can be stopped by depressing the throttle, clutch, or brake pedal. If the engine continues to idle, the ATS warm-up function will try to raise the idle speed until the ATS temperatures are suitable.

Engine Indicator Lamps

General Information

The following engine indicator lamps cover only the lamps controlled by the engine ECM.

Wait to Start Lamp

The WAIT TO START lamp illuminates when the intake air heater needs to warm the intake air prior to starting the engine. The WAIT TO START lamp on time will vary depending on the ambient air temperature.

The WAIT TO START lamp is amber and looks similar to this:



Check Engine Lamp

The CHECK ENGINE lamp illuminates when the engine needs to be serviced at the first available opportunity.

The CHECK ENGINE lamp is amber, and looks similar to this:



Another function of the CHECK ENGINE lamp is to flash for 30 seconds at key-on when one of the following occurs. This flashing function is referred to as the MAINTENANCE lamp. The MAINTENANCE lamp could flash for any of the following reasons:

- Maintenance required (if the Maintenance Monitor is enabled).
- Water-in-fuel is detected.
- Coolant level is low.

Stop Engine Lamp

The STOP ENGINE lamp indicates, when illuminated, the need to stop the engine as soon as it can be safely done. The engine must remain shut down until the engine can be repaired.

For engines with the Engine Protection shutdown feature enabled, if the STOP ENGINE lamp begins to flash, the engine will automatically shut down after 30 seconds. The flashing STOP engine lamp alerts the operator to the impending shut down.

The STOP ENGINE lamp is red in color, and looks similar to this:



Malfunction Indicator Lamp (MIL)

The engine in this vehicle is required to conform to EPA Heavy Duty On-Board Diagnostic (OBD) regulations. OBD exist to make sure the engine is operating within the prescribed emissions limits. The OBD system monitors the ATS to detect malfunctions that adversely affect emissions. If a malfunction is detected the malfunction indicator lamp (MIL) will illuminate, and a diagnostic fault code will be logged in the engine control module.

The MIL lamp is amber, and looks similar to this:



Diesel Particulate Filter (DPF) Lamp

The DPF lamp indicates, when illuminated or flashing, that the DPF needs to be regenerated.

The DPF lamp is amber, and looks similar to this:



An illuminated DPF lamp indicates that the DPF needs to be regenerated at the next possible opportunity. This can be accomplished by:

1. Changing to a more challenging duty cycle, such as highway driving, for at least 20 minutes.
2. Have a Cummins authorized repair location perform a stationary regeneration.

NOTE: Stationary regeneration is considered a normal maintenance practice and is not covered by Cummins Inc. warranty.

A flashing DPF lamp indicates that the DPF needs to be regenerated at the next possible opportunity. Engine power may be reduced automatically.

When the DPF lamp is flashing, the operator should:

1. Change to a more challenging duty cycle, such as highway driving, for at least 20 minutes.
2. Have a Cummins authorized repair location perform a stationary regeneration.

A flashing DPF lamp combined with an illuminated CHECK ENGINE lamp indicates that the DPF needs be regenerated immediately. Engine power will be reduced automatically. When these lamps are illuminated together you should **immediately** seek service from a Cummins authorized repair location.

NOTE: If the engine is unable to complete a DPF regeneration cycle, the STOP ENGINE lamp will illuminate and the vehicle will have to be towed to a Cummins authorized repair location.

High Exhaust Temperature (HEST) Lamp



The HEST lamp is amber, and looks similar to this:

The HEST lamp indicates, when illuminated, that exhaust temperatures are high due to regeneration of the DPF. The lamp could illuminate during normal engine operation or during stationary regeneration.

NOTE: The OEM determines whether or not the HEST lamp is installed on the vehicle. The OEM also specifies the temperatures, vehicle speeds, and other conditions at which the lamp illuminates. Refer to the OEM service manual for additional information regarding this lamp.

When this lamp is illuminated, make sure the exhaust pipe outlet is not directed at any surface or material that will melt, burn, or explode.

- Keep the exhaust outlet away from people, and anything that can burn, melt, or explode.
- Nothing within 0.6 m [2ft] of the exhaust outlet
- Nothing that can burn, melt, or explode within 1.5 m [5ft] (such as gasoline, wood, paper, plastics, fabric, compressed gas containers, or hydraulic lines).
- In an emergency, turn off the engine to stop the flow of exhaust.

NOTE: The HEST lamp does not signify the need for any kind of vehicle or engine service; it merely alerts the vehicle operator to high exhaust temperatures, it will be common for the HEST lamp to illuminate on and off during normal vehicle operation as the engine completes regeneration.

Diesel Exhaust Fluid (DEF) Lamp



The DEF lamp is amber, and looks similar to this:

The DEF lamp indicates, when illuminated or flashing, that the diesel exhaust fluid level is low.

Diesel Exhaust Fluid (DEF) Lamp (cont.)

An illuminated DEF lamp indicates that the DEF level has fallen below the initial warning level. This can be corrected by filling the DEF tank with diesel exhaust fluid.

NOTE: It is recommended that the DEF tank be filled completely full of diesel exhaust fluid in order to correct any fault conditions.

A flashing DEF lamp indicates that the DEF level has fallen below the critical warning level. This can be corrected by filling the diesel exhaust fluid tank with diesel exhaust fluid.

NOTE: It is recommended that the DEF tank be filled completely full of diesel exhaust fluid in order to correct any fault conditions.

A flashing DEF lamp combined with an illuminated WARNING or CHECK ENGINE lamp indicates that the DEF level has fallen below the initial derate level. The engine power will be limited automatically. This can be corrected by filling the DEF tank with diesel exhaust fluid.

NOTE: It is recommended that the diesel exhaust fluid tank be filled completely full of diesel exhaust fluid in order to correct any fault conditions.

If the engine has been shut down, idled for 1 hour, or if fuel has been added after the DEF tank has been emptied, the STOP ENGINE lamp will also illuminate along with the flashing DEF lamp and illuminated CHECK ENGINE lamp. The engine vehicle speed will also be limited to 5 mph.

NOTE: In order to remove the 5 mph speed limit, the diesel exhaust fluid tank must be filled to at least 10 percent volume of the tank.

NOTE: It is recommended that the DEF tank be filled completely full of diesel exhaust fluid in order to correct any fault conditions.

Engine Starting

Warning

Do not use starting fluids with this engine. This engine is equipped with an intake air heater. Use of starting fluids could cause an explosion, fire, personal injury, severe damage to the engine, and property damage.

NOTE: For cold-weather starting, see “Cold-Weather Operation” in Section 1 of the Cummins Engine Owner’s Manual.

NOTE: Cummins electronic engines are run on a dynamometer before being shipped from the factory. They do not require a break-in period.

IMPORTANT: Special break-in oils are not recommended for new or rebuilt Cummins engines.

NOTICE

If a vehicle does not start on the first attempt, make sure that the engine has completely stopped rotating before reapplying the starter switch. Failure to do so can cause the pinion to release and re-engage, which could cause ring gear and starter pinion damage.

IMPORTANT: Ring gear and starter pinion damage caused by improper starting procedures is not warrantable.

NOTICE

Do not crank the engine for more than 30 seconds at a time. Wait two minutes after each try to allow the starter to cool. Failure to do so could cause starter damage.

NOTICE

If the engine is equipped with a turbocharger, protect the turbocharger during start-up by not opening the throttle or accelerating the engine above 1000 rpm until normal engine idle oil pressure registers on the gauge.

Starting

Set the parking brake.

1. Place the transmission in neutral.
2. Turn the key to the ON position.
3. Wait a minimum of 10 seconds. If the “Wait-to-Start” lamp is still illuminated after 10 seconds, continue to wait until the lamp is no longer illuminated. The wait to start lamp may stay illuminated for up to 30 seconds depending on ambient temperature.
4. Start the engine.
5. NOTE: See the Cummins Operation and Maintenance Manual for detailed information on starting procedures.

Cold-Weather Starting

Turn the ignition switch to the on position. If the Wait-To-Start lamp  is illuminated, wait until it goes out before trying to start the engine. The Wait-To-Start lamp will stay on for up to 30 seconds. The length of time it remains illuminated depends on the ambient temperature. Once the Wait-To-Start lamp goes off, turn the key to the start position. If the engine doesn't start after 30 seconds of cranking, turn the key to the off position and wait two minutes; then repeat the starting procedure. Once the engine is started, let it run at idle for 3 to 5 minutes before driving. If normal engine oil pressure doesn't show on the gauge within 15 seconds of starting, shut the engine off and contact your nearest Cummins authorized repair location for assistance.

If the unit is equipped with a block heater, start the block heater 2 to 4 hours before travel.

Engine Braking

Important: The engine brake is a vehicle slowing device, not a vehicle stopping device. It is not a substitute for the vehicle service brakes. Use of the engine brake for vehicle downhill control, and slowing down on level terrain will help the service brakes to remain cool and ready for an emergency. Engine braking is covered thoroughly in section 3.

Warning

Do not use the engine brake on wet, icy, or snow-covered roads. Using the engine brake could result in loss of vehicle control, possibly causing personal injury, death, or property damage.

Cruise Control

Warning

Do not use the cruise control system when driving conditions do not permit maintaining a constant speed, such as in heavy traffic or on roads that are winding, icy, snow covered, slippery, or roads with a loose driving surface. Failure to follow this precaution could cause a collision or loss of vehicle control, possibly resulting in personal injury, death, or property damage.

NOTICE

Cruise control allows you to automatically control the speed of the vehicle above 32 MPH (50 km/h).

Do not shift to Neutral (N) when using cruise control. This will cause the engine to over-speed, which can damage the engine.

Cruise On/Off

Press the cruise control ON/OFF switch to activate the cruise control or to turn it off.

Cruise Set

Press the cruise control SET switch to set the desired cruising speed.

Cruise Resume

Press the cruise control RESUME switch to resume cruise control activation.

Disengage Cruise

Disengage the cruise control by depressing the service brake, or by switching the cruise on/off switch to the off position.

Engine Shutdown

1. With the vehicle stopped, place the transmission in the Neutral (N) position, and set the parking brake using the parking brake control knob.
2. It is important to idle an engine for 3 to 5 minutes before shutting it down. This allows the lubricating oil and the water to carry heat away from the combustion chambers, bearings, shafts, etc. This is especially important with turbo-charged engines.
3. Do not idle the engine for long periods.
4. If the engine is not being used, shut it down by turning the ignition key to the OFF position.
5. Allow a minimum of 3 minutes after the engine is turned off before switching off the chassis battery disconnect.

Diagnostic Fault Codes

The engine control (ECM) monitors the engine sensors and parameters while the engine is in operation. The ECM can detect certain conditions that are outside of the normal operating parameters. The ECM will log diagnostic fault information, and illuminate the check engine light, stop engine light, or the malfunction indicator light to inform the operator of a problem. It will also log diagnostic fault information in the form of numeric codes to assist a technician in troubleshooting the concern.

Diagnostic fault codes fall into two categories; active faults, and historic faults. Active faults indicate the condition causing the fault is still present. Historic faults indicate the condition causing the fault is no longer present, but remain in the ECM memory to assist the technician when diagnosing the concern.

Active fault codes can be retrieved by the operator using the dash instrumentation. This can be helpful in determining if the condition is serious, and needs immediate attention, or if it is safe to continue operating the engine until it is convenient for the operator to have the service work performed.

Retrieve active fault codes using the following steps:

1. Simultaneously press both buttons at the base of the speedometer – release when you see “Setup” appear on the screen

CUMMINS ENGINES

2. Use the button labeled “Next” (left side) to scroll down the menu
3. Stop when “Active Fault Codes” is highlighted
4. Press the button labeled “Select” (right side)
5. Two pieces of information will be displayed
 - a. SPN followed by a 3 or 4 digit number
 - b. FMI followed by a 1 or 2 digit number

Provide these two pieces of information to a Tiffin phone tech, or the nearest Cummins authorized repair location for guidance on how you should proceed.

Towing

The Allegro Bay is capable of towing typical motor vehicles or trailers up to 7,500 lbs. The motor home is equipped with a towing hitch, and associated wiring connector. The total weight of the motor home and any vehicle towed must not exceed the Gross Combined Weight Rating (GCWR). When the motor home is weighed, remember to account for passengers and their locations in the motor home. Any vehicles or trailers to be towed by the motor home should have adequate active braking.

Scheduled Maintenance

SCHEDULED MAINTENANCE

Scheduled Maintenance

SERVICE INTERVAL (Miles x 1,000)	Annually	5	10	15	20	50	Required Fluids, Lubricants, and Procedures
Air System:							
Air Dryer		X					Inspect for leaks and blockage of purge valve (8)
Air Intake Screen		X					Inspect for blockage
Primary Air Tank Reservoir		X					Open drain to release excess moisture before and after each trip
Secondary Air Tank Reservoir		X					Open drain to release excess moisture before and after each trip
Brake Systems:							
ABS Sensors						X	Clean sensors & adjust into hub rings
Brake Pads, Rotors, Shoes & Drums					X		Inspect pads, shoes, rotors & drums for wear and cracks (1)
Slack Adjusters					X		Inspect slack adjuster for proper adjustment – lubricate w/ NGLI #2 grease
Brake Hoses/Whips, Front & Rear			X				Inspect for leaks, & cracking.
Cooling Systems:							
A/C Condenser Fins			X				Inspect for blockage and wash clean every 10k or as needed
Charge Air Cooler Fins			X				Inspect for blockage and wash clean every 10k or as needed
Fan & Fan Shroud					X		Inspect for blockage and cracks.
Radiator Fins/Grill			X				Inspect for blockage and wash clean every 10k or as needed
Radiator Hoses & Pipes			X				Inspect for kinks, chaffing wear and leaks.
Surge Tank Cap		X					Inspect for leak
Surge Tank Vent Lines		X					Inspect for kinks and leaks daily
Electrical Systems:							
Rear Electrical Compartment		X					Check for loose fuses and cables
Front Electrical Compartment		X					Check for loose fuses and cables
Generator Cables		X					Check for loose red & black cables connected to generator
Batteries		X					Inspect for leaks / check for loose lugs / remove any corrosion

SCHEDULED MAINTENANCE

SERVICE INTERVAL (Miles x 1,000)	Annually	5	10	15	20	50	Required Fluids, Lubricants, and Procedures
Engine Systems:							
Engine Oil Filter	X			X			Replace engine oil filter per engine manual (1)
Engine Oil	X			X			Change engine oil per engine manual (1)
Exhaust Muffler & Piping			X				Inspect for pinholes, rust and leaks
Engine Air Filter	X	X					Check restriction indicator - replace filter as needed (7)
Fuel Tank Vent Lines					X		Inspect for "P" traps that may cause air locks and slow filling
Fuel Tank & Lines			X				Inspect for leaks around fuel inlet nipples and hoses
Engine Coolant		X					Test coolant inhibitor level and freeze protection every 6 months (11)
Primary Fuel Filter	X			X			Replace fuel filter per engine manual (1)
Secondary Fuel Filter	X			X			Replace fuel filter per engine manual (1)
Air Intake Piping (filter to turbo)		X					Inspect for rubbing, holes, broken or loose clamps. Repair any problems immediately
Engine Crankcase Breather							Replace every 60,000 miles
Serpentine Belt				X			Inspect for cracks across belt section, replace if any are found. Check for correct tension and wear.
Steering Systems:							
Steering Gear			X				Inspect mount bolts for looseness & hydraulic hoses for leaks
Steering Gear Pump			X				Inspect for hydraulic hose leaks at fittings
Steering Shaft U-Joints			X				Inspect for loose fasteners
Steering Shaft Boot			X				Inspect for clearance between boot & shaft, lubricate w/ NGLI #2 grease
Steering Fluid			X				Check fluid level and inspect for leaks
Steering Fluid Change						X	Change fluid at 5 years or 50,000 miles (9)
Suspension & Axles:							
Coach Alignment				X			Align coach as needed (4)
Front Ride Height Adjust					X		Adjust to 8 ¾" measuring bottom of frame rail to center of hole in lower height control valve linkage bracket
Rear Ride Height Adjust					X		Adjust to 7" from bottom of rail to centerline of axle
Ride Height Valve Linkages					X		Grease linkage grommets w/D.A. Stewart Aqualube
Air Suspension Bags			X				Inspect for leaks at fittings and inspect bags for leaks or cracks
Front Axle Bearings					X		Inspect seals for leakage and repair as necessary
Front Axle Tie Rods - Inspect					X		Inspect for looseness
Front Axle King Pins					X		Lubricate W/NGLI #2 grease every 90 days or 25,000 miles
Front & Rear Shocks			X				Inspect for leaks on shock tube, replace as needed
Drive Axle Lube					X		Inspect for leaks & check fluid level. Use synthetic oil only 75W90 (3)
Wheel Lug Torque			X				Re-torque all wheels nuts - Torque 450-500 lbs (2)

SCHEDULED MAINTENANCE

SERVICE INTERVAL (Miles x 1,000)	Annually	5	10	15	20	50	Required Fluids, Lubricants, and Procedures
Suspension & Axles:							
Automatic Slack Adjusters					X		Lubricate W/NGLI #2 grease (1)
Slack Adjuster Cam Shafts					X		Lubricate W/NGLI #2 grease (1)
Slack Adjuster Clevis Pins					X		Inspect for wear in clevis pin and cotter pins. Replace as necessary
Transmission & Driveline:							
Drive Shaft					X		Inspect u- for loose bolts & wear, lubricate w/NGLI #2 grease (1)
Transmission Fluid							Replace fluid every 4 years or 150,000 miles (5)
Transmission Filters							Replace filters every 2 years or 50,000 miles (5)

- (1) Replace / inspect at stated mileage interval or every 12 months, whichever occurs first.
- (2) Re-torque all wheel nuts after the first 100 miles, then every 10K miles thereafter.
- (3) Factory filled with synthetic oil. Do not mix with mineral oils. Change fluid every 3 years or 50K miles.
- (4) For best tire life and handling, alignment of front axle is recommended every 15K miles.
- (5) Factory filled with Allison approved TES-295 fluid. To maintain these service intervals, fluid must not be mixed with Dexron or other fluids.
- (6) Total fluid capacity is 24oz. Use only synthetic 75W90 oil. Change every 3 years or 50K miles.
- (7) Replace filter when indicator shows 25 inches or every 12 months, whichever occurs first.
- (8) Replace desiccant cartridge every 36 months.
- (9) Change fluid every 5 years or 50K miles.
- (10) Factory filled with 80W90 mineral oil. Do not mix with synthetic. Change fluid every 3 years or 50K miles.
- (11) Drain, flush, and refill with new antifreeze/coolant every 5 years. Only use coolants that meet or exceed Cummins requirements. Refer to appropriate Cummins literature for specifications. 2009 - 2016 model year coaches were factory filled with Shell Rotella ELC. 2017 to present models are factory filled with Old World Final Charge Global.

Fluids

Engine Oil

The primary oil recommendation for the ISB engine is a high-quality SAE 15W-40 oil with API classification CJ-4 that meets CES-20081 standards. If the engine is to be consistently operated in extreme cold temperatures, -15°C (5°F), an SAE 5W-40 full synthetic oil is recommended. The Cummins engine in your coach was factory filled with Shell Rotella 15W-40 motor oil.

Cummins does not recommend special break-in oils for this engine. The factory fill oil can be run until the first oil change interval is reached.

Cummins does not recommend the use of aftermarket oil additives in their engines. High-quality 15W-40 engine oils with API classification CJ-4 meeting CES-20081 standards are precisely blended with the necessary additives. Additional additives are not necessary to enhance the oil performance.

Please refer to your Cummins ISB Owner's Manual for more details on engine oils, and other engine maintenance.

Engine Coolant

The engine cooling system in your coach was factory filled with Old World Final Charge Global, Nitrite-Free Coolant. Old World Final Charge Global is a fully formulated, organic acid technology (OAT) coolant designed to protect all metals within the cooling system.

Do not mix or dilute the coolant in your coach with water, or other non-compatible coolants. If you need to top off your cooling system use only Old World Final Charge Global 50/50 premixed coolant. If the coolant does become diluted with water, or another non-compatible coolant a complete drain, flush, and refill of the cooling system is required.

Test the coolant in your coach for freeze protections, and inhibitors every 5000 miles, or at least twice annually. Test strips can be purchased from Old World Industries or one of its distributors.

The engine coolant in your coach should be replaced every 5 years. Drain, flush, and refill with new coolant. Be sure to use a coolant that meets or exceeds Cummins Engineering Standard, CES-14603. Please refer to your Cummins ISB Owner's Manual for more details on the required coolant specifications.

Engine Coolant (cont.)

IMPORTANT! When refilling the cooling system follow these instructions:

- 1) Remove surge tank lid/ radiator cap. (located on the surge tank)
- 2) Fill radiator through the surge tank (5 GPM max)
- 3) Once coolant is visible and halfway up the sight glass on the surge tank, start and run engine at idle for one minute, then at high idle for an additional two minutes.
- 4) Return engine to idle and if necessary, top off surge tank until coolant is visible halfway up the sight glass and close lid tightly.



NOTE: A complete drain, flush, and refill should be done at an authorized service center.

Diesel Exhaust Fluid (DEF)

DEF (diesel exhaust fluid) is used to reduce the NOx (nitrogen oxides) emissions from your engine exhaust system. DEF is non-flammable, non-toxic, and non-polluting. DEF can be corrosive to certain materials. If DEF is spilled, rinse and clean the area immediately with clear water.

It is recommended that you only use DEF certified by the American Petroleum Institute (API) in your vehicle. Look for this symbol on the container, or dispensing system to identify the fluid has been certified by the API.



DEF has a limited shelf life. Normal shelf life is around 18 months if stored in a sealed container at temperatures between 23°F and 77°F. DEF should not be stored in direct sunlight as this will reduce the shelf life of the product. If your coach is in storage for a period of 6 months or longer you should have the condition of the DEF tested before use. Testing should be done using a DEF refractometer. The DEF should show 32.5% Urea concentration, +/- 1.5%. If the DEF test outside of this parameter the tank should be drained, flushed with distilled water, and filled with new DEF.

DEF consumption will vary depending on your driving habits, and operating conditions. Generally DEF consumption will be 2 to 4 gallons for every 100 gallons of diesel fuel burned for the ISL engine. Consumption on the ISB engine will be higher. ISB engines will consume 3 to 6 gallons of DEF for every 100 gallons of fuel burned.

SCHEDULED MAINTENANCE

DEF freezes around 12°F. The DEF system on your vehicle is designed to accommodate this condition and does not require any intervention from the operator.

NEVER add anything other than new or known good DEF to the tank. If the tank is accidentally contaminated by another fluid the tank should be drained, flushed with distilled water, and filled with new DEF.

Differential Oil

The differential in your coach was factory filled with Shell Spirax 75W-90 full synthetic lubricant. The fluid level should be checked every 10K miles. If make-up oil is required use only full synthetic 75W-90 lubricants. Never mix mineral oils with synthetic lubricants.

The differential oil should be changed every 3 years or 50,000 miles, whichever occurs first.

Transmission Fluid

The transmission in your coach was factory filled with Shell Spirax S6 A295 synthetic fluid. Spirax S6 A295 is an Allison approved TES-295 fluid. Allison approved TES-295 fluids extend both the service intervals, and the warranty for your transmission. Continued use of TES-295 fluid provides extended warranty coverage up to 5 years or 200,000 miles whichever occurs first.

Transmission fluid should be checked on a regular basis. It is recommended to check fluid at the end of the day when the transmission is at full operating temperature. Fluid should be checked with the park brake set, the engine running at idle, the transmission in neutral, and the transmission temperature above 140°F.

Transmissions do not consume fluid. If you find the need to regularly add fluid to your transmission a leak has developed and you should seek service from an Allison authorized dealer as soon as possible.

Change the transmission fluid and filter every 5 years or 200,000 miles, whichever occurs first.

Please refer to your Allison Transmission Operators Manual for additional information on transmission fluids, and other transmission maintenance.

Lubrication Points

Drivers Side Front Lubrication Points:

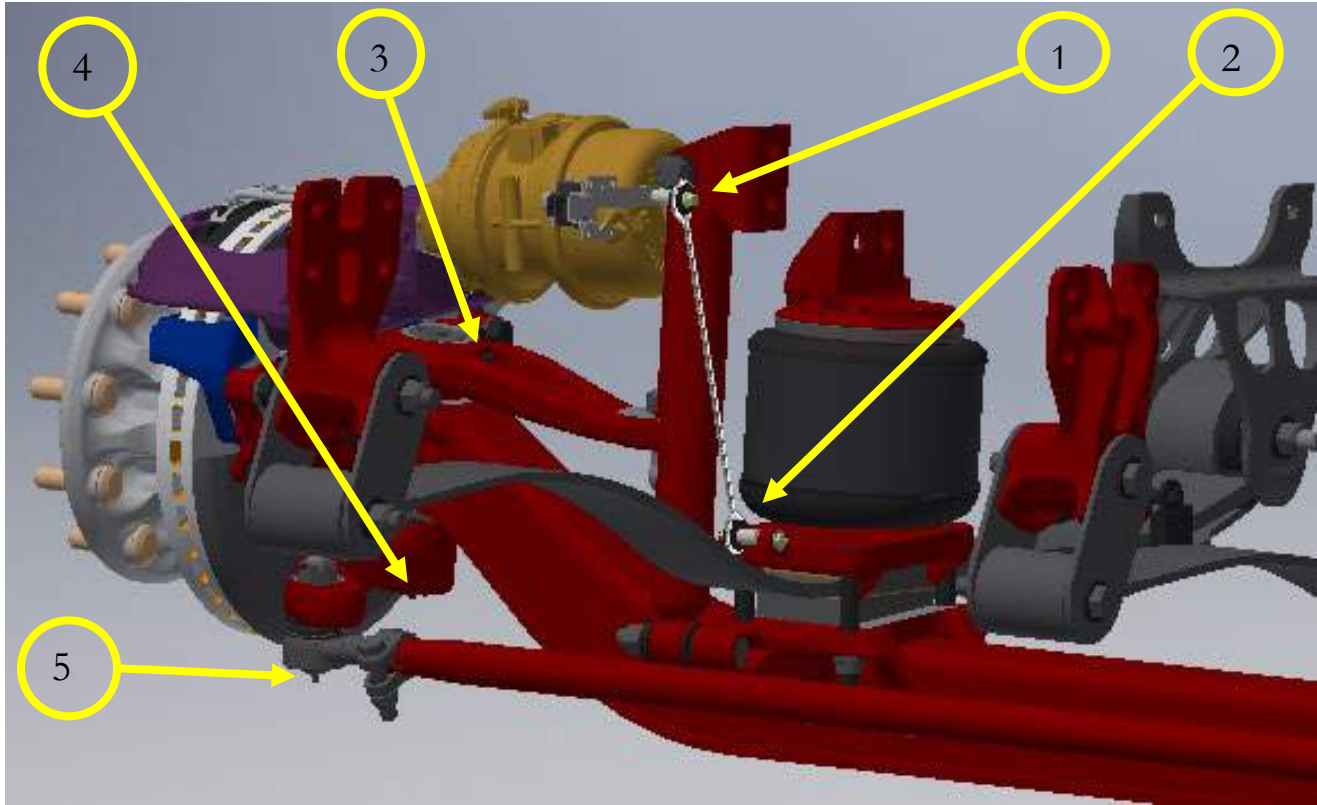

1. Upper Height Control Sensor Linkage Connection
2. Lower Height Control Sensor Linkage Connection
3. Upper Kingpin
4. Lower Kingpin
5. Tie Rod End

Passenger Side Front Lubrication Points:

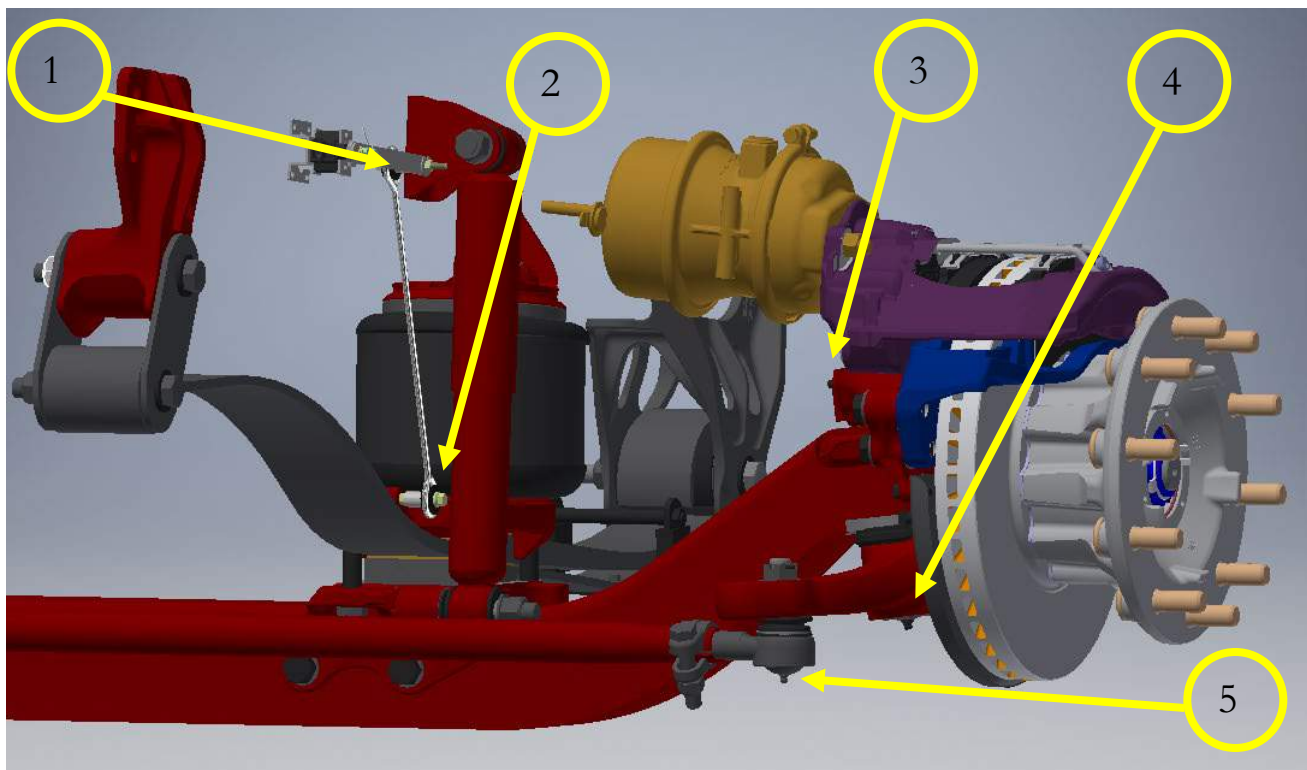

1. Upper Height Control Sensor Linkage Connection
2. Lower Height Control Sensor Linkage Connection
3. Upper Kingpin
4. Lower Kingpin
5. Tie Rod End

Rear Suspension Lubrication Points:

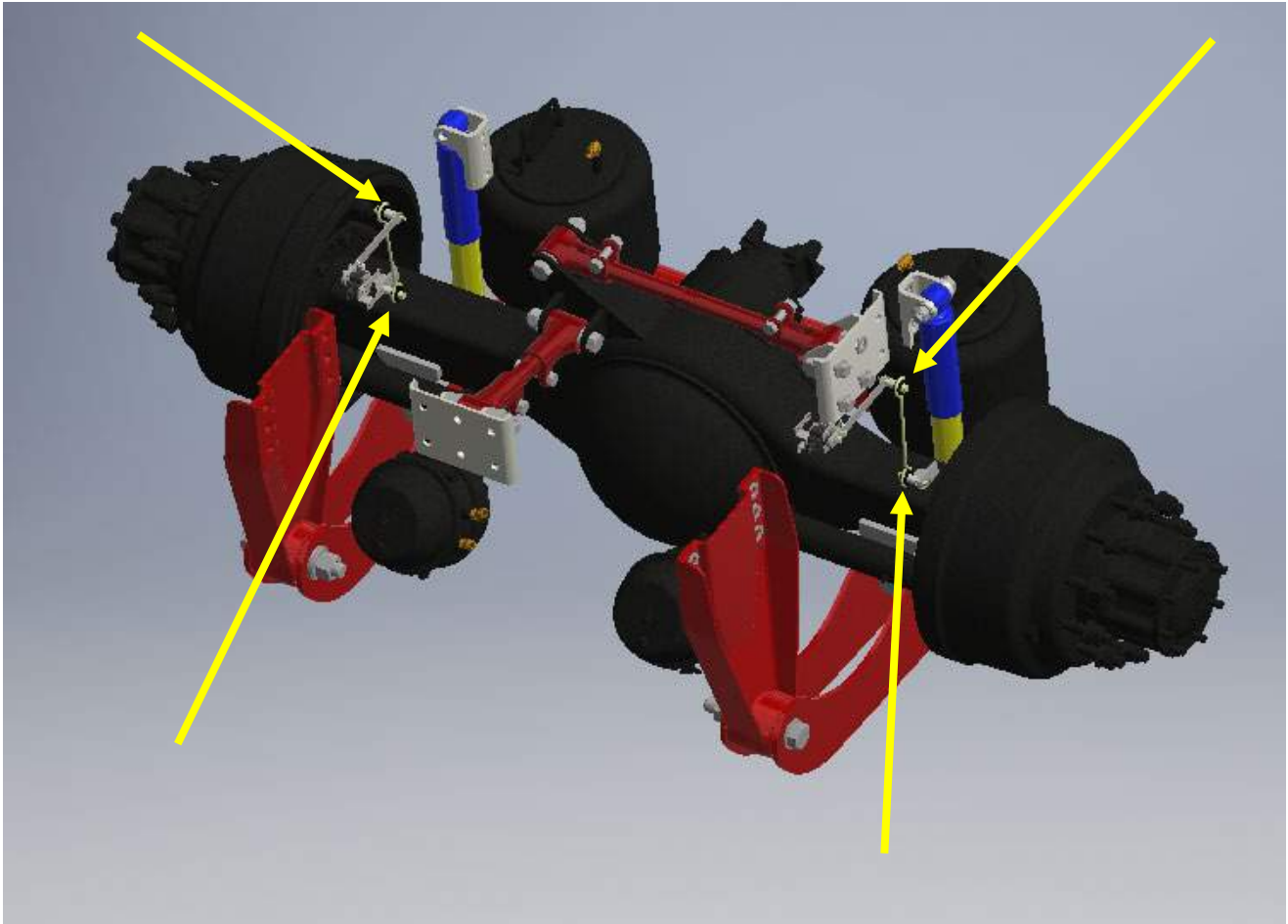

Upper and Lower Height Control Sensor Linkage Connections

Rear Axle Lubrication Points:

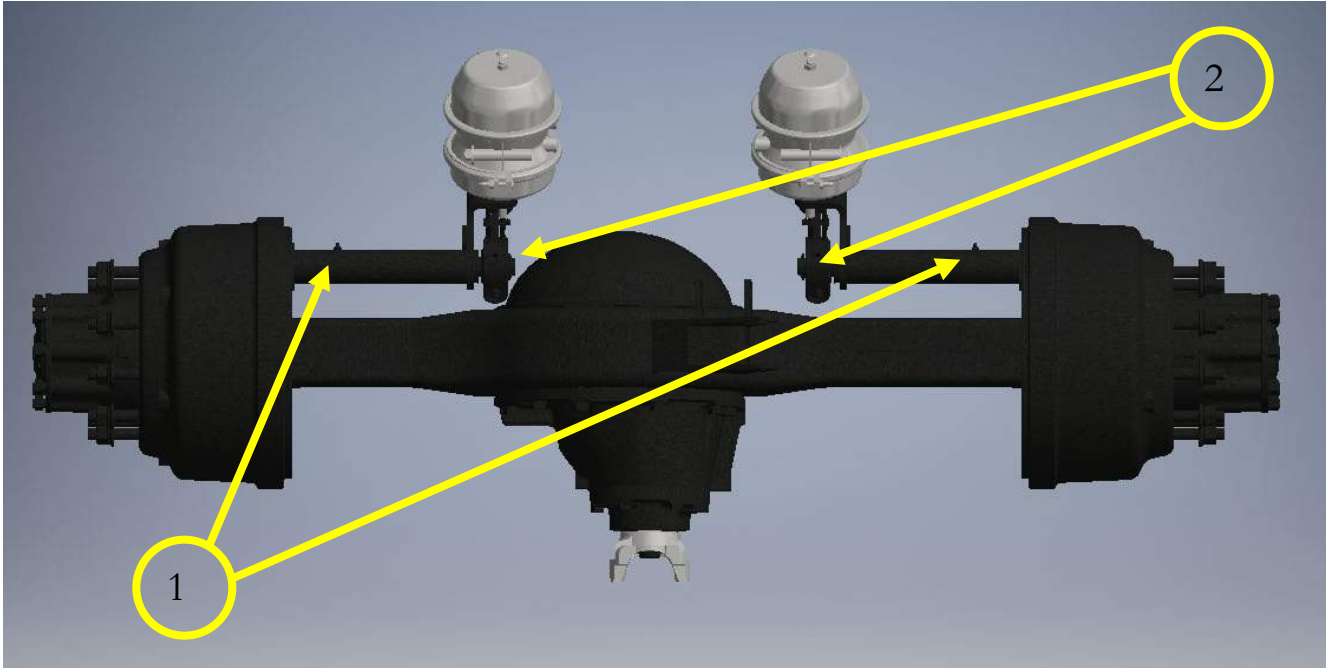

1. Rear Brake Camshaft Bracket
2. Automatic Slack Adjusters

Main Driveshaft

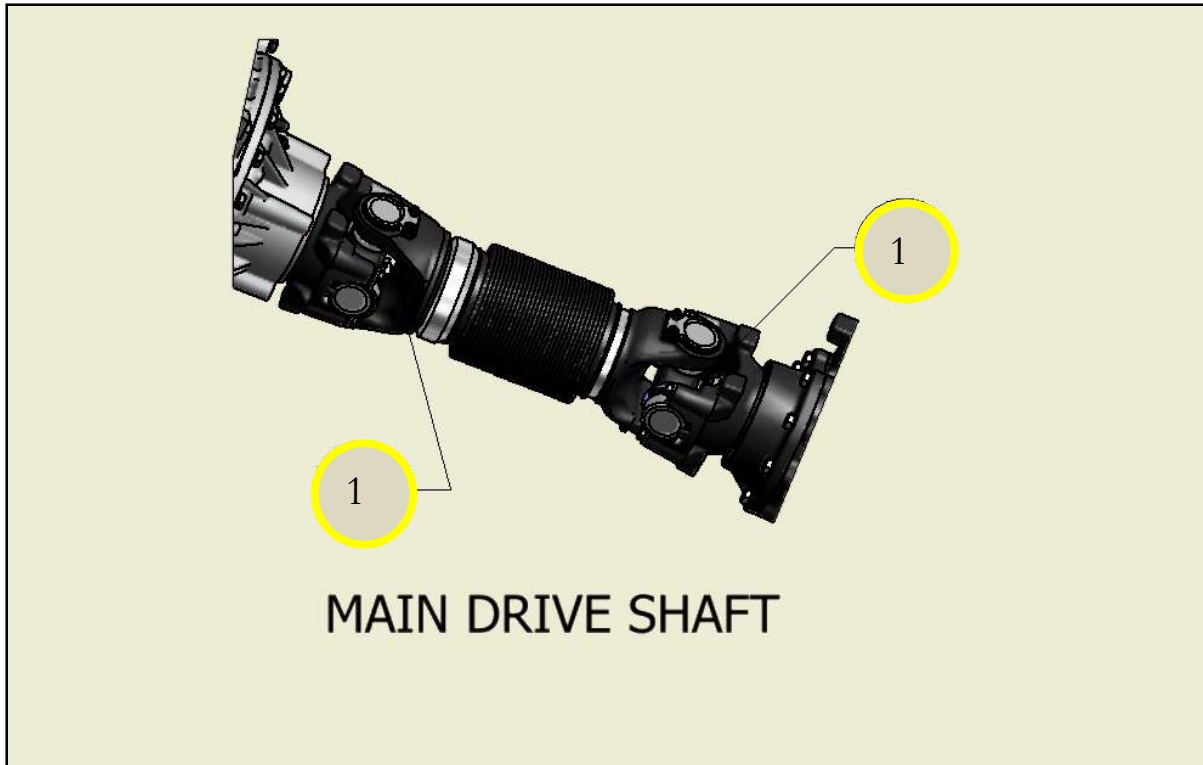

1. Lubricate Each Universal Joint at Each Grease Fitting.

Maintenance Parts

Primary Fuel Filter/Water Sep W/WIF sensor

Cummins Filtration part # FS1098

NO Tiffin part #

Secondary Fuel Filter

Cummins Filtration part # FF63009

Tiffin part # 5059830

Engine Oil Filter

Cummins Filtration part # LF3970

NO Tiffin part #

Engine Air Filter

Parker/Racor # 062891001

Tiffin part # 5059543

Serpentine Belt

Cummins part # 3978294

NO Tiffin part #

**For assistance with your
Tiffin PowerGlide Chassis**

Please contact one of the following
chassis specialists at Tiffin Motorhomes, Inc.

256-356-8661

Service

Greg Dees

Billy Payne, extension 3862

Ricky Brown, extension 3861

Parts

Heath Thorne, extension 3860

Mechanical Engineering

Corbette Davis, extension 2125

Electrical Engineering

Chris Struzik, extension 2363

Plant Manager

Gary Harris, extension 2288

Please have your **Chassis VIN #** ready
when you call.

SCHEDULED MAINTENANCE

Pre-Trip Inspection

Pre-Trip Inspection

- Check fluid levels & add as necessary
- Check tire inflation pressure
- Look for fluid leaks

Before starting your motor home daily, a few things must be checked. By doing so, you ensure that a safe trip is in order and lessen your chances of experiencing difficulties while on the road.

- Check the tires for proper inflation pressure and any damage. Also check the inner duals. Refer to the air pressure charts in this manual for proper inflation pressures.
- Look for fluid leaks under the motor home. This can prevent any serious problems from occurring later.
- Check the coolant level in the reservoir and add Old World Final Charge Global coolant if necessary. This reservoir can be found on the rear of your vehicle.
- Check SCA (supplemental coolant additive) and freeze point every 6 months, or sooner if coolant has been diluted with water.

Caution

If the water temperature in your engine is greater than 120 degrees, do not remove the radiator cap! You could be severely burned.

- Approximate COOLING SYSTEM CAPACITIES – does not include the heater core or other auxiliary systems.
- Cummins ISB – Rear Radiator 44.5qt. or 11.125 gallons
- Check transmission fluid level
- Check engine oil level
- Check for small animals in engine compartment, such as squirrels and cats
- Check the power steering fluid reservoir

Check fuel/water separator

ISB

- Check fuel/water separator and drain any water or contamination that may be present. This must be done with the engine off.

PRE-TRIP INSPECTION

After you have completed your inspection, you may now start your engine. Turn the key to the run position and wait for the wait to start light to turn off. You may now start the engine. ***Never use ether or any other starting fluids to start the electronic engine. The inlet heater can ignite the fumes and cause an explosion in the air inlet system.*** Once you have started the engine, monitor your gauges carefully. Make sure that the oil pressure rises within 15 seconds. If it does not, shut down the engine and call a repair facility to determine the cause.



Figure 6-1: Filter Restriction Indicator

- Check air filter restriction indicator (Figure 6-1)

Brand New Air Cleaner
10" to 12" of Vacuum

- **Change the engine air filter element when the air inlet restriction indicator reaches 25 inches of vacuum or once a year, whichever occurs first.**

Instruments & Controls

Tiffin Instrument Panel

The Instrument Panel Assembly (IPA) of the Tiffin Allegro Breeze is equipped with Medallion Instrumentation Systems' Graphical Data Interface Gauge (GDIG). This section briefly describes and illustrates the system.

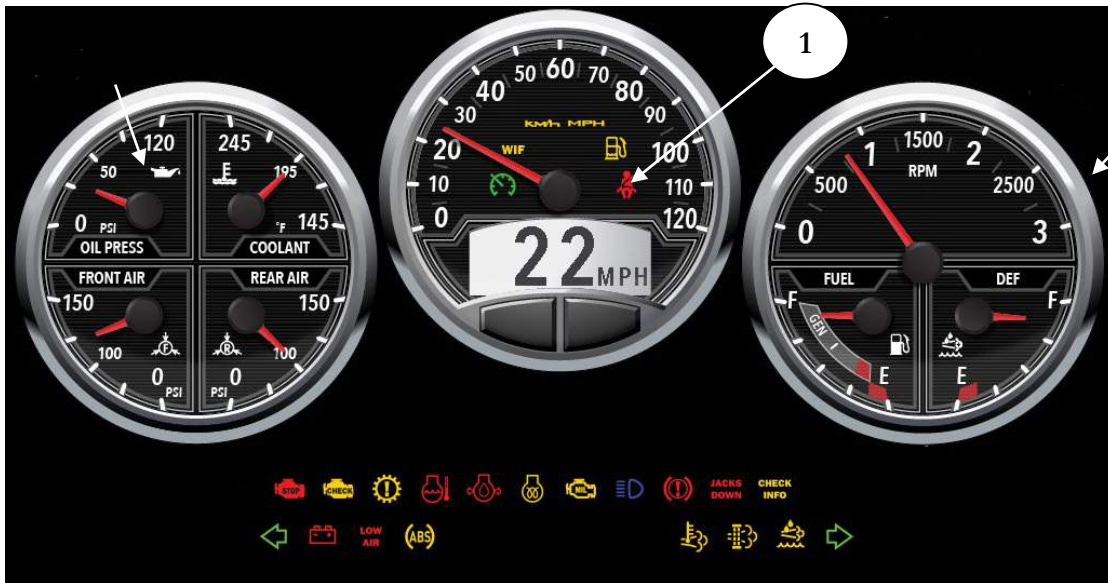

1. 4N1 Gauge

- Front air
- Rear air
- Oil pressure
- Coolant temperature

2. Speedometer

- Instrument system controller for the Instrument Panel Assembly (IPA)
- Speedometer scale
- Two integral buttons for controlling the LCD
- Speedometer icons (Figure 7-1)

INSTRUMENTS & CONTROLS







NAME	GRAPHIC	COLOR	CONTROL
SEAT BELT		RED	30 SEC
LOW FUEL		AMBER	ON SOLID
CRUISE		GREEN	ON SOLID
WATER IN FUEL		AMBER	ON SOLID
MPH		AMBER	ON SOLID
KMH		AMBER	ON SOLID

Figure 7-1: Speedometer icons

3. 3N1 Gauge

- Tachometer (RPM)
- Fuel tank levels for main fuel tank and generator
- Diesel Exhaust Fluid (DEF) level

4. Chameleon Warning Lamp Assembly (Figures 7-2 and 7-3)

Figure 7-2: Warning lamp assembly



INSTRUMENTS & CONTROLS



ANTILOCK BRAKE SYSTEM



LOW VOLTAGE



LOW AIR



WAIT TO START

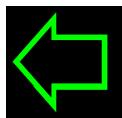

LEFT TURN



RIGHT TURN

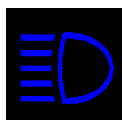

HIGH BEAM



JACKS DOWN



DPF STATUS



HIGH EXHAUST TEMP



OIL PRESSURE



HIGH COOLANT TEMP



LOW DEF LEVEL



CHECK INFO



STOP ENGINE



CHECK ENGINE



CHECK TRANSMISSION



PARK BRAKE



MALFUNCTION INDICATION LAMP

Figure 7-3: Warning lamp descriptions

Driver's Information Center

The speedometer includes a Graphical Drivers Information Center. The functions of the Driver's Information Center can be broken down into four broad categories:

1. Display of user selectable pre-drive checklist items
2. Display of user selectable driver information screens
3. Display of warning messages
4. Display of utility screens

Pre-Drive Checklist

Note: This option is disabled by default. To activate, press and hold both LCD control buttons simultaneously and the setup menu will appear. Use the left button to scroll down to pre-drive checklist and right button to select. A menu of items will appear for the pre-drive checklist. Scroll to each item using the left button and use right button to change item from off to on. To exit the setup menu, scroll down to exit setup and press right button, or turn the key switch off.

- The Pre-Drive Checklist is displayed immediately following the Tiffin Splash Screen each time the IPA is enabled.
- Pre-Drive Checklist Screens are easily identified by the "Pre-Drive Checklist" title bar across the top of the screen in reverse video.
- Each item in the list must be acknowledged by the operator by pressing either button on the DIG. When acknowledged, the screen scrolls to the next item in the checklist. When all items have been acknowledged, the DIG displays the last Driver Information Screen viewed.
- Edit Function: The checklist items actually displayed at start up shall be user selectable from a master list of items available in the set up menu. You can elect to display all of the items, some of the items, or none of the checklist items as desired.
- By default, the speedometers shall ship from the factory with all Pre-Drive Checklist Item de-selected.
- The Master Pre-Drive Checklist Items include:
 - JACKS / AIR LEVELER UP
 - CHECK TOW VEHICLE
 - TIRE PRESSURE
 - ENGINE MAINTAINANCE
 - DISCONNECT POWER
 - DISCONNECT WATER
 - DISCONNECT SEWER
 - BAY DOORS CLOSED

INSTRUMENTS & CONTROLS

- SHOWER DOOR LOCKED
- ROOF VENTS CLOSED
- AWINING ARMS LOCKED
- COUNTERTOP CLEAR
- ALL DOORS LOCKED
- DRAWERS LATCHED
- APPLIANCES SECURED
- SLIDES IN AND SECURED
- WINDOWS CLOSED
- CB RADIO ON

Driver Information Screen

1. Driver Information Screens are provided to communicate important information about the vehicle and its performance to the driver.
2. Driver Information Screens are easily identified by the reverse video title bar across the top of each screen clearly identifying what is being displayed.
3. The available Driver Information Screens are:
 - Odometer & Gear
 - Engine Load
 - Transmission Temperature
 - Fuel Economy
 - Engine RPM
 - Engine Hours
 - Battery Voltage

Note: The Odometer & Gear Screen may not be disabled and is always available. Other Driver Information Screens may be displayed or not displayed as desired by the driver. The factory default setting is all Driver Information Screens enabled.

Warning Messages

The following conditions will prompt warning messages:

ALARM CONDITION	SOURCE	NOTES
"LOW VOLTAGE"	J-1939	
"TRANSMISSION TEMP"	J-1939	
"COMMUNICATION ERROR"	J-1939	Engine, Trans, or ABS
"TURN SIGNAL ON"	DIG	Turn Signal "On" + 1 Mile Traveled
"GENERATOR LOW FUEL"	DIG	Generator "On" + Fuel \leq 20%

Notes:

1. Each of the above alarms will turn on the “Check Info” Warning Lamp.
2. Each of the above alarms will activate audible alarm 4.
3. Each of the above alarms require user acknowledgement to clear.

Utility Screens

1. The SETUP Menu shall be accessed by simultaneously pressing the left and right display buttons for 3 seconds. When this condition is sensed the Drivers Information Center shall briefly display the word SETUP and then display a list of menu items with the top item in the list highlighted in reverse video.
2. On each utility screen, the function of the left and right display switches shall be displayed in the LCD above each switch.
3. To exit the SETUP Menu, the operator must scroll down the list using the left display button until the EXIT SETUP menu item is highlighted and then press the right display button to SELECT the highlighted action. The LCD shall briefly display the word WAIT as the DIG resets.
4. The following Utilities shall be available in the SETUP Menu:
 - **UNITS:** Pressing the Right Display Button (CHANGE) while the UNITS menu item is highlighted shall toggle the units from English to metric or vice versa. The change shall be immediate and can be confirmed by viewing the speedometer units icons. MPH shall be illuminated when English units are selected and KM/h shall be illuminated when metric units are selected.
 - **LCD ANIMATION:** Pressing the Right Display Button (CHANGE) while the LCD ANIMATION menu item is highlighted shall toggle the LCD Animation State from ON to OFF or vice versa. In the ON state, a TIFFIN MOTORHOMES Splash Screen shall be displayed when the system is starting up and each time the operator scrolls between Drivers Information Screens. In the OFF state, these screens shall not be displayed.
 - **LCD SCREENS:** Pressing the Right Display Button (SELECT) while the LCD SCREENS menu item is highlighted shall bring up a master list of Drivers Information Screens showing the name and the display selection status of each screen (Enabled or Disabled). Pressing the Left Display Button (NEXT) shall allow the operator to scroll to each item in the list. Pressing the Right Display Button (Change) shall toggle the display selection status of the highlighted item from Enabled to Disabled or vice versa. If no button presses are sensed in 5 seconds, the display shall jump back to the SETUP Menu Screen.
 - **PRE-DRIVE CHECKLIST:** Pressing the Right Display Button (SELECT) while the PRE-DRIVE CHECKLIST menu item is highlighted shall bring up a master list of Pre-Drive Checklist Tasks showing the task name and the selection status of each screen (ON or OFF). Pressing the Left Display Button (NEXT) shall allow the operator to scroll to each item in the list. Pressing the Right Display Button (Change) shall toggle the selection status of the highlighted item from OFF to ON or vice versa. If no button presses are sensed in 5 seconds, the display shall jump back to the SETUP Menu Screen.
 - **LCD BACKLIGHT:** Pressing the Right Display Button (SELECT) while the LCD BACKLIGHT menu item is highlighted shall bring up a bar graph illustrating the LCD

Backlight Brightness setting as a percentage of maximum brightness. Pressing the Left Display Button (DEC) decreases the display brightness and pressing the Right Display Button (INC) increases the display brightness. The change shall be immediate. If no button presses are sensed in 5 seconds, the display shall jump back to the SETUP Menu Screen.

- **LCD CONTRAST:** Pressing the Right Display Button (SELECT) while the LCD CONTRAST menu item is highlighted shall bring up a bar graph illustrating the LCD Contrast setting. Pressing the Left Display Button (DEC) decreases the display brightness and pressing the Right Display Button (INC) increases the display brightness. The change shall be immediate. If no button presses are sensed in 5 seconds, the display shall jump back to the SETUP Menu Screen.
- **ACTIVE FAULT CODES:** Pressing the Right Display Button (SELECT) while the ACTIVE FAULT CODES menu item is highlighted shall bring up a list of any active fault codes that are currently being broadcast. The SPN and FMI shall be displayed for each active code. Pressing the Right Display Button (NEXT) shall scroll to the next active fault in the list. Pressing the Left Display Button (EXIT) shall force a return to the SETUP Menu Screen.
- **GAUGE DIAGNOSTICS:** Pressing the Right Display Button (SELECT) while the GAUGE DIAGNOSTICS menu item is highlighted shall bring up a screen that lists all of the analog inputs to the DIG and their current input voltage expressed as an A/D count. From this screen, pressing either Display Button shall bring up a screen that lists all of the digital inputs to the DIG and their current state expressed as either High or Low. From this screen, pressing either Display Button shall bring up a J1939 VEHICLE DATABUS Screen. From this screen, pressing either Display Button shall force a return to the SETUP Menu Screen.
- **IP TEST ROUTINE:** Pressing the Right Display Button (SELECT) while the IP TEST ROUTINE menu item is highlighted shall initiate the following sequence of events:
 1. The Drivers Information Center shall display the text: IP TEST and alternate between normal and reverse video
 2. All six icons in the speedometer shall be illuminated.
 3. Light Bar icons shall be illuminated
 4. Each gauge shall sweep from zero to mid-scale, from mid-scale to max-scale, and back to zero. This exercise shall be repeated twice.
 5. At the conclusion of the gauge exercise the test routine is terminated and the LCD returns to the SETUP Menu Screen.
- **SET ODOMETER:** Caution: This is a service function used to program a service replacement speedometer. Pressing the Right Display Button (SELECT) while the SET ODOMETER menu item is highlighted brings up a service utility that is used to load the vehicle's actual mileage should the speedometer ever have to be replaced. Pressing the Right Display Button (CANCEL) returns to the SETUP Menu Screen. This function is locked out when the reading reaches 100 miles.
- **GAUGE INFORMATION:** Pressing the Right Display Button (SELECT) while the GAUGE INFORMATION menu item is highlighted brings up a screen that displays the

revision level and date of the firmware installed in DIG. Pressing either Display Button returns to the SETUP Menu Screen

- **RESTORE DEFAULTS:** Pressing the Right Display Button (SELECT) while the RESTORE DEFAULTS menu item is highlighted causes all user selections to revert to the factory default conditions of:
 - ENGLISH Units
 - LCD Animation ON
 - All LCD Screens ENABLED
 - All Pre-Drive Checklist items OFF

After the button is pressed the display automatically returns to the SETUP Menu Screen.

- **EXIT SETUP:** Pressing the Right Display Button (SELECT) while the EXIT SETUP menu item is highlighted causes the DIG to reset and return to normal operation.

Trip Reset and Average Fuel Economy

You can reset your mileage for Trip 1 and Trip 2. With the odometer screen displayed, press and hold left button to reset trip 1; press and hold the right button to reset trip 2. To reset the average fuel economy, display the fuel economy screen. Push and hold the left button to reset the average fuel economy reading.

Modes of Operation

The Instrument Panel Assembly (IPA) has two operational modes:

- **OFF:** In the off state, the following ICONS are still operational:
 - Left turn signal
 - Right turn signal
 - High beam
 - Jacks down

All other IPA features are disabled.

- **Normal Mode:** The default operational mode is Normal Mode. In Normal Mode, all of the features of the IPA are available to the operator. The gauges, light bar, and driver's information center are all fully operational.

Air Supply

Air Supply

Two auxiliary air sources are provided for customer use. One in the front electrical compartment, and one at the rear of the coach near the air tank drains. These air supply connections can supply up to 120psi, although the volume of air at these connections is low. For maximum air pressure at these connections, start and run the engine at 1000 rpm during use. These connections are on a pressure protected manifold, no air will be available at these connections when tank air pressure is below 85psi.



Figure 8-1: Front Customer Air Supply



Figure 8-2: Rear Customer Air Supply

- Manifold provided for auxiliary air source
 - Up to 120 psi
 - Quick connect fittings already installed at rear
- Can be used for:
 - Air horn supply
 - Fill tires
 - Etc.

Note: All unused ports must be plugged.

Warning

Air tanks should be bled of all pressure before any work is done on the air system!

AIR SUPPLY

Warranty

Warranty

- **Engine**

- Cummins ISB: 5 Years or 100,000 miles

- **Transmission**

- Allison 2500 MH Series: 5 Years or 200,000 miles

- **Chassis**

- 3 Years or 50,000 miles

- **Drive Train**

- 3 Years or 50,000 miles

- **Suspension**

- 3 Years or 50,000 miles

- **GHG Emission Components**

- **Tires:** Tiffin Motor Homes, Inc. warrants that its vehicles are designed, built and equipped with tires that conform, at the time of sale, with requirements of vehicle manufactures whose vehicles are designed to meet applicable 2014 - 2019 U.S. Environmental Protection Agency and National Highway Traffic and Safety Administration greenhouse gas and fuel efficiency standards, and those tires are free from defects in material and workmanship which cause the vehicle to fail to conform with the vehicle manufacture's requirements for a period of 2 years or 24,000 miles, whichever occurs first. Claims for failures under this coverage are filed directly to the tire manufacture.

WARRANTY



Tiffin Motorhomes Owners Club, Red Bay, AL

902-A Gates Street, Red Bay AL 35582 (256) 356-8522

The Tiffin Allegro Club is the owner's club for all owners of any Tiffin built motorhome. The Club maintains an office near the Tiffin service center/campground and is open Monday – Friday. You will find a great supply of logo wear here, a small customer lounge, and friendly staff to make your visit to Red Bay more enjoyable.

Club members benefit from attending Tiffin rallies held across the nation, receive discounts from various vendors such as Michelin Tires, Passport America, Enterprise, etc., and develop comradery and friendship with other owners. With the purchase of a new, untitled coach, the first year's membership is complimentary from Tiffin Motorhomes. Renewals are very reasonable and discounts are offered for multiple years. You may join or renew memberships online at www.TiffinMotorhomes.com in the OWNERS section or by calling/visiting the Tiffin Allegro Club office at (256) 356-8522. News about the Club can be found at our online news blog, www.TiffinSideroads.com. Enter your email address in order to receive notices about upcoming events.

You must be a current member of the Tiffin Allegro Club in order to participate in our very popular Tiffin rallies. Rallies are usually four nights and include live entertainment, informative seminars, catered meals, and social activities such as craft shows, ice cream get-togethers, and swap meets. As a 'thank you' for your brand loyalty, Tiffin Motorhomes often sends a group of service technicians to the rallies to perform minor repairs and adjustments on your coach. A local dealer is present with a display of the newest and latest Tiffin coaches. Rallies sell out quickly! Registration information can be found at www.TiffinMotorhomes.com for all upcoming events.

In addition to the international Tiffin Allegro Club, Tiffin also has local chapters across the USA and in some Canadian provinces. These local chapters get together regularly for outings and activities. Check out the local chapter in your area by visiting the CHAPTERS page at www.Tiffinmotorhomes.com for contact information.

Membership in the Tiffin Allegro Club can play a vital part in maximizing the enjoyment you receive from owning a Tiffin built coach. For more information, please contact the Tiffin Allegro Club at (256) 356-8522. Wherever you go, we go!