

TIFFIN MOTORHOMES, INC.

105 2<sup>nd</sup> Street NW ♦ Red Bay, Alabama 35582 U.S.A.

# 2021 PowerGlide® Owner's Manual



**WARNING:** Breathing diesel engine exhaust exposes you to chemicals known to the State of California to cause cancer and birth defects or other reproductive harm.

- Always start and operate the engine in a well-ventilated area.
- If in an enclosed area, vent the exhaust to the outside.
- Do not modify or tamper with the exhaust system.
- Do not idle the engine except as necessary.

For more information go to [www.P65warnings.ca.gov/diesel](http://www.P65warnings.ca.gov/diesel).

TIFFIN MOTORHOMES, INC.

# Allegro Breeze Chassis Owner's Manual

---

© Tiffin Motorhomes, Inc.  
105 2<sup>nd</sup> Street NW, Red Bay, AL 35582 U.S.A.  
Telephone 256.356.8661 • Facsimile 256.356.8219  
E-Mail: [info@tiffinmotorhomes.com](mailto:info@tiffinmotorhomes.com)

## DISCLAIMER

Many of the features and appliances described in this manual may or may not be reflected in the actual motor home purchased, depending on the options and models selected by the motorhome owner. All items, materials, instructions, and guidance described in this manual are as accurate as possible at the time of printing. However, because of Tiffin Motorhomes' ongoing and dedicated commitment to excellence, improvement of Tiffin motorhomes is a continuing process. Consequently, Tiffin Motorhomes reserves the right to make substitutions and improvements in its makes and models of motorhomes without prior notification. Substitutions of comparable or better materials, finishes, appliances, instrumentation, and instruction may be made at any time it is deemed prudent to provide the customer with the best possible motorhome meeting the customer's requirements.

Copyright © 2020 by Tiffin Motorhomes, Inc. -- all rights reserved

Printed in the United States of America: Third U.S. Printing: 2020

[20200416]

---

**Tiffin Allegro Breeze - PowerGlide Chassis  
Customer Support  
256-356-0261  
Monday-Friday  
7 a.m. - 4:30 p.m. CST**

If you should require chassis service, *you should first contact your nearest Tiffin Powerglide® Chassis service center.* Use [https://tiffinmotorhomes.com/locate\\_dealer/map.php](https://tiffinmotorhomes.com/locate_dealer/map.php) to find and authorized warranty service facility. If for some reason this is not possible or if you would like to call the manufacturers direct, you can contact them at the following telephone numbers:

**TIFFIN POWERGLIDE CHASSIS**

256-356-0261

**(Please have your VIN# ready)**

**SAFE RIDE**

(Nights and weekends)

1-877-276-0619

**CUMMINS ENGINE COMPANY**

1-800-CUMMINS (286-6467)

**ALLISON TRANSMISSIONS**

1-800-524-2303

**MICHELIN TIRE**

800-TIRE-HELP (800-847-3435)

Visit our website at [www.tiffinmotorhomes.com](http://www.tiffinmotorhomes.com)

# Table of Contents

<hr/> <b>Chapter 1</b> <hr/>		<hr/> <b>Chapter 4</b> <hr/>	
<b>Tire Care</b>		<b>Engine</b>	
Tire Care	1-2	EPA Mandates	4-3
Correct Tire Pressure	1-3	ATS Warning Lamps	4-4
Emissions and Fuel Efficiency Compliance	1-4	DPF Maintenance	4-4
		Aftertreatment Operation	4-5
		Engine Indicator Lamps	4-7
		Engine Starting	4-11
		Cold Weather Starting	4-12
		Engine Braking	4-12
		Cruise Control	4-13
		Engine Shutdown	4-14
		Diagnostic Fault Codes	4-14
		Towing	4-15
<hr/> <b>Chapter 2</b> <hr/>		<hr/> <b>Chapter 5</b> <hr/>	
<b>Brake System</b>		<b>Allison Transmission Operation</b>	
Brake System	2-2	Driving Considerations	5-2
Compressed Air System	2-3	Fluid Level Check	5-3
Air Dryer	2-4		
<hr/> <b>Chapter 3</b> <hr/>		<hr/> <b>Chapter 6</b> <hr/>	
<b>Maintenance</b>		<b>Instruments &amp; Controls</b>	
Scheduled Maintenance Chart	3-2	Safety	4
Fluids	3-5	Overview	5
Lubrication Points	3-8	Gauge Quick Reference	8
Maintenance Parts	3-12	Navigation	9
Tiffin Assistance	3-13		

# ALLEGRO BREEZE POWERGLIDE CHASSIS MANUAL

<b>Indicators</b>	<b>10</b>
<b>Main Gauges</b>	<b>14</b>
<b>Selectable Display</b>	<b>18</b>
<b>Additional Displays</b>	<b>23</b>
<b>Leveling</b>	<b>24</b>
<b>Alarm Messages</b>	<b>27</b>
<b>Menu Map</b>	<b>32</b>
<b>TPMS</b>	<b>36</b>
<b>Diagnostics</b>	<b>40</b>

---

## **Chapter 7**

---

### **Leveling**

<b>Safety Instructions</b>	<b>4</b>
<b>Overview</b>	<b>5</b>
<b>Operation</b>	<b>6</b>
<b>Leveling</b>	<b>8</b>
<b>System Commands</b>	<b>17</b>
<b>Status Messages</b>	<b>20</b>

---

## **Chapter 8**

---

### **Pre-Trip Inspections**

<b>Pre-Trip Inspection</b>	<b>8-2</b>
----------------------------	------------

---

## **Chapter 9**

---

### **Warranty**

<b>Warranty</b>	<b>9-2</b>
-----------------	------------

---

## **Chapter 10**

---

### **Allegro Owner's Club**

<b>Allegro Club</b>	<b>10-2</b>
---------------------	-------------

# TIRE CARE

---

# TIRE CARE

- What is the most important component of tire care?

- ✓ TIRE PRESSURE

- Why?
  - ✓ Improved Ride
  - ✓ Improved Tire Wear
  - ✓ Improved Road Handling
  - ✓ Improved Braking



## Tire Care

Maintaining the proper tire inflation pressure is the most important thing you can do to maximize the life of your tires. An under-inflated tire can build up excessive heat that may go beyond the prescribed limits of endurance of the rubber and the radial cords. Over-inflation will reduce the tire's footprint on the road, reducing traction, braking capacity, and the handling of your vehicle. An over-inflated tire will also cause a harsh ride, uneven tire wear, and will be more susceptible to impact damage.

Keep in mind that the pressure rating on the side wall of your tire is the *maximum* pressure for that tire. This is not necessarily the *correct* pressure for the tires when installed on *your* vehicle. Maintaining the correct tire pressure for *your vehicle's loaded weight* is extremely important and must be a part of regular vehicle maintenance.

# Correct Tire Pressure

- How to determine the correct pressure
  - ✓ Weigh each wheel position
  - ✓ Set tire pressure according to chart



\* This Chart Shows Cold Inflation Pressures

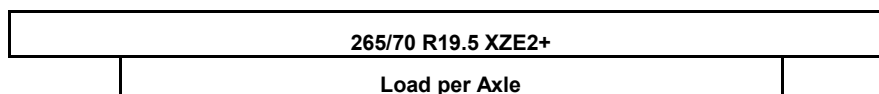

PSI=>		65	70	75	80	85	90	95	100	105	110	Max Load per Tire
KPA=>		450	480	520	550	590	620	660	690	720	760	
<b>Single</b>	<b>LBS</b>	7,230	7,680	8,110	8,540	8,970	9,390	9,800	10,210	10,620	11,020	5,510
<b>Dual</b>	<b>LBS</b>	13,660	14,500	15,320	16,140	16,940	17,740	18,520	19,300	20,060	20,820	5,205
<b>Single</b>	<b>KG</b>	3,280	3,460	3,700	3,860	4,080	4,240	4,460	4,620	4,780	5,000	2,500
<b>Dual</b>	<b>KG</b>	6,200	6,520	6,960	7,280	7,720	8,040	8,440	8,720	9,040	9,440	2,360

To determine the correct air pressure for your tires, load your motor home as you would normally travel, including water and fuel. Go to a truck scale as found at most major truck stops and weigh **each wheel position** independently, with driver and passenger(s) in the vehicle as described in the *Michelin Recreational Vehicle Tire Guide* (MWLA3146 Rev. 03/12) to determine the correct air pressure for the weight on each wheel position. Then use the charts in the guide and adjust the pressure accordingly when the tires are cool or have not been driven for more than one mile. You may call 1-800-847-3435 for a copy of the *Michelin Recreational Vehicle Tire Guide*, or visit: <https://www.michelintruck.com/reference-materials/manuals-bulletins-and-warranties/load-and-inflation-tables/#/>

**NOTE:** Never reduce the air pressure in a hot tire.

**REMEMBER:** For control of your RV, it is critical that the tire pressure be the same on both sides of the axle.



# Emissions and Fuel Efficiency Compliance

Your chassis was designed, and built, with components including, but not limited to, low rolling resistance tires specifically designed and manufactured to exacting standards for regulatory fuel efficiency and greenhouse gas emissions compliance. The vehicle owner is responsible for being sure these components are replaced with the same or equivalent components that maintain compliance with federal and local regulations.

For help with determining tires that are the same or equal in regards to rolling resistance for maintaining compliance with the regulatory standards, please contact Michelin at 1-800-947-3435.

# **Brake System**

---

## Brake System



Figure 2-1: Rear Brakes

- Front brakes are air applied disc
- Rear brakes (Figure 2-1) double as parking brake
  - Park brakes are spring applied
  - Two large 15 x 8.625” drum brakes
  - Park brake remains applied even if air pressure is lost
- If air pressure is lost
  - A buzzer and warning lamp will alert you
- Chassis is equipped with automatic slack adjusters (Figure 2-2)
  - No brake adjustment required



Figure 2-2: Automatic Slack Adjuster

The rear brakes on the PowerGlide chassis are also used as the parking brakes. This provides you the holding power of two large drum brakes to prevent your coach from rolling, even when fully loaded on a 20% grade.

A decrease in air pressure will **not** cause an immediate loss of brakes. If a leak develops in the air system while driving, at approximately **60 to 65 PSI** you will be alerted via a light on the instrument panel, and an audible alarm will sound. As you apply the brakes, the air supply holding the park brakes in the released position will

## BRAKE SYSTEM

gradually be depleted. When fully depleted, approximately **40 PSI to 45 PSI**, the rear brakes will set. This allows you sufficient time to pull over to the side of the road.

**NOTE:** The rear brakes have dual chambers – one for the service brakes and one for the park brake. The service brakes are air applied and spring released. The park brake is spring applied and air released.

The brake system is equipped with automatic slack adjusters that avoid the need to manually adjust your brakes. Each time you step on the brake pedal, if adjustment is needed, the adjusters will take up the slack.

## Compressed Air System

### Tank Drains



Figure 2-3: Tank Drains

The compressed air system is comprised of two air storage tanks. The primary tank stores and supplies air for the rear brakes, the secondary tank stores and supplies air for the front brakes.

When air is compressed it becomes hot. As it cools condensed moisture forms in the system. The air system is equipped with an air dryer to remove most of this moisture. The dryer has an automatic moisture ejector that releases the trapped moisture back into the atmosphere. However, some moisture will form in the system beyond the dryer, and make its way into the storage tanks. As moisture collects in the primary and secondary tanks, it displaces the area needed for air storage, thus requiring that the tanks be drained periodically.

## BRAKE SYSTEM

The air system is equipped with air tank drains conveniently located in the left rear storage compartment (Figure 2-3). There is one drain for the primary tank and one for the secondary tank. These drains should be **opened daily** for a few seconds to remove any moisture trapped in the tanks.

### Air Dryer



Figure 2-4: Parker Air Dryer

The Tiffin PowerGlide chassis air brake system features a Parker air dryer (Figure 2-4), which removes the condensed moisture from compressed air. The air dryer is equipped with a desiccant cartridge that needs to be changed **every 36 months**. The dryer is located on the driver's side behind the compartment that holds the a/c condenser and air tanks.

### Warning

Air tanks should be bled of all pressure any time you perform work on the air system.

# Maintenance

---

MAINTENANCE

# Scheduled Maintenance

SERVICE INTERVAL (Miles x 1,000)	Daily	5	10	15	20	Required Fluids, Lubricants, and Procedures
<b>Air System:</b>						
Air Dryer		X				Inspect for leaks and blockage of purge valve (9)
Air Intake		X				Inspect for blockage at intake screen on rear cap
Air Filter		X				Check restriction indicator - replace filter as needed (6)
Primary Air Tank Reservoir	X					Drain condensation daily
Secondary Air Tank Reservoir	X					Drain condensation daily
<b>Brake Systems:</b>						
ABS Sensors					X	Clean sensors & adjust into hub rings. (1)
Brake Pads, Rotors, Shoes & Drums					X	Inspect pads, shoes, rotors & drums for wear and cracks. (1)
Slack Adjusters					X	Inspect slack adjuster for proper adjustment & grease.
Brake Hoses/Whips, Front & Rear			X			Inspect for leaks, & cracking.
<b>Cooling Systems:</b>						
A/C Condenser Fins			X			Inspect for blockage and wash clean every 10k or as needed
Charge Air Cooler Fins			X			Inspect for blockage and wash clean every 10k or as needed
Fan & Fan Shroud		X				Inspect for cracks.
Radiator Fins/Grill			X			Inspect for blockage and wash clean every 10k or as needed
Radiator Hoses & Pipes				X		Inspect for kinks, chaffing wear and leaks.
Coolant Level	X					Check for correct level in sight glass
Coolant Leaks	X					Inspect for visual signs of coolant on the ground
Coolant Testing		X				Test coolant for freeze protection and inhibitors (10) (11)
<b>Electrical Systems:</b>						
Rear Electrical Compartment		X				Check for loose fuses and cables
Front Electrical Compartment		X				Check for loose fuses and cables
Generator Cables		X				Check for loose red & black cables connected to generator
Alternator Belt			X			Check for correct tension and wear
Batteries		X				Check for loose lugs / remove any corrosion

MAINTENANCE

# Scheduled Maintenance

SERVICE INTERVAL (Miles x 1,000)	Daily	5	10	15	20	Required Fluids, Lubricants, and Procedures
<b>Engine Systems:</b>						
Drive Belt Condition			X			Inspect belt condition for cracks or other damage. Replace as necessary.
Engine Oil Filter				X		Replace engine oil filter per engine manual (1)
Engine Oil Level	X					Check level daily
Engine Oil				X		Change engine oil per engine manual (1)
Exhaust & Aftertreatment		X				Inspect for signs of leakage, rust and pinholes.
Diesel Fuel						Always use ultra-low sulfur fuel only
Fuel Tank Vent Lines					X	Inspect for "P" traps that may cause air locks and slow filling
Fuel Tank & Lines			X			Inspect for leaks around fuel inlet nipples and hoses.
Engine Coolant						Replace coolant that has been diluted with water or non-compatible coolant (11)
Stage 1 Fuel Filter				X		Replace fuel filter per engine manual (8)
Stage 2 Fuel Filter				X		Replace fuel filter per engine manual (8)
Crankcase Ventilation Filter						Replace at 75,000 miles
<b>Steering Systems:</b>						
Steering Gear Arm			X			Inspect for looseness.
Steering Gear			X			Inspect mount bolts for looseness & hydraulic hoses for leaks.
Steering Gear Pump			X			Inspect for hydraulic hose leaks at fittings.
Steering Shaft U-Joints & Pinch Bolts			X			Inspect for loose fasteners & lube bearings w/NGLI #2.
Steering Shaft Boot			X			Inspect for clearance between boot & shaft
<b>Suspension &amp; Axles:</b>						
Coach Alignment				X		Align coach as needed (4)
Front Ride Height Adjust			X			Inspect to make sure ride height is within specifications
Rear Ride Height Adjust			X			Inspect to make sure ride height is within specifications
Ride Height Valve Linkages			X			Grease linkage grommets w/D.A. Stewart Aqualube.
Air Suspension Bags			X			Inspect for leaks at fittings and inspect bags for leaks or cracks
Front Axle Bearings		X				Check fluid level through sight window, if low, repair leaks as necessary (7)
Front Axle Tie Rods - Inspect					X	Inspect for looseness
Front Axle Tie / Relay Rods - Lubricate			X			Lubricate W/NGLI # 2 grease
Front Axle Idler Arm			X			Lubricate W/NGLI #2 grease
Front & Rear Shocks			X			Inspect for leaks on shock tube, replace as needed



MAINTENANCE

# Scheduled Maintenance

SERVICE INTERVAL (Miles x 1,000)	Daily	5	10	15	20	Required Fluids, Lubricants, and Procedures
<b>Suspension &amp; Axles:</b>						
Rear Axle Lube			X			Check fluid level & Inspect for leaks. Use synthetic oil only 75W90 (3)
Wheel Lug Torque			X			Re-torque all wheel nuts – Torque 450-500 ft. lbs. (2)
Automatic Slack Adjusters			X			Lubricate W/NGLI #2 grease
Slack Adjuster Cam Shafts			X			Lubricate W/NGLI #2 grease
Slack Adjuster Clevis Pins			X			Inspect for wear in clevis pin and cotter pins. Replace as necessary
<b>Transmission &amp; Driveline:</b>						
Drive Shaft			X			Inspect u-joints & straps for loose bolts & wear, lubricate w/NGLI #2 grease
Transmission Fluid						Replace fluid at 150,000 miles or 48 months whichever occurs first. (5)
Transmission Filters						Replace filters at 50,000 miles or 24 months whichever occurs first. (5)

- (1) Replace / inspect at stated mileage interval or every 12 months whichever occurs first
- (2) Re-torque all wheel nuts after the first 100 miles, then every 10K miles thereafter.
- (3) Factory filled with synthetic oil. Do not mix with mineral oils. Change oil every 3 years or 50,000 miles whichever occurs first
- (4) For best tire life and handling, alignment of front axle is recommended every 25K miles.
- (5) Factory filled with an Allison approved TES-295 fluid. To maintain these service intervals use **only** Allison approved TES-295 fluids
- (6) Replace filter when indicator shows 25 inches or every 12 months whichever occurs first.
- (7) Factory filled with 80W-90 mineral oil. Do not mix with synthetic oils. Change hub oil every 3 years or 50,000 miles whichever occurs first
- (8) Replace at stated mileage interval or every 12 months whichever occurs first.
- (9) Replace desiccant cartridge every 36 months.
- (10) Check coolant for freeze protection and inhibitors every 5000 miles or twice annually.
- (11) Drain, flush, and replace the engine coolant every 5 years.

# Fluids

## Engine Oil

The Cummins ISB engine in your coach was factory filled with Valvoline SAE 10W-30 motor oil. A florescent dye was added to the oil at the factory which will give the oil a red tint. This dye is used by Cummins to help detect oil leaks during engine testing. The dye does not affect the performance of the factory fill oil.

The primary oil recommendation for the ISB engine is a high-quality SAE 10W-30 oil with API classification CJ-4 that meets CES-20081 standards. If the engine is to be consistently operated in extreme cold temperatures, -15°C (5°F), an SAE 5W-40 full synthetic oil is recommended.

Cummins does not recommend special break-in oils for the ISB engine. The factory fill oil can be run until the first oil change interval is reached.

Cummins does not recommend the use of aftermarket oil additives in the ISB engine. High-quality 10W-30 engine oils with API classification CJ-4 meeting CES-20081 standards are precisely blended with the necessary additives. Additional additives are not necessary to enhance the oil performance.

Please refer to your Cummins ISB Owner's Manual for more details on engine oils, and other engine maintenance.

## Engine Coolant

The engine cooling system in your coach was factory filled with Old World Final Charge Global, Nitrite-Free Coolant. Old World Final Charge Global is a fully formulated, organic acid technology (OAT) coolant designed to protect all metals within the cooling system.

Do not mix or dilute the coolant in your coach with water, or other non-compatible coolants. If you need to top off your cooling system use only Old World Final Charge Global 50/50 premixed coolant. If the coolant does become diluted with water, or another non-compatible coolant a complete drain, flush, and refill of the cooling system is required.

Test the coolant in your coach for freeze protections, and inhibitors every 5000 miles, or at least twice annually. Test strips can be purchased from Old World Industries or one of its distributors.

The engine coolant in your coach should be replaced every 5 years. Drain, flush and refill with new coolant. Be sure to use a coolant that meets or exceeds Cummins Engineering Standard, CES-14636. Please refer to your Cummins ISB Owner's Manual for more details on the required coolant specifications.

## Engine Coolant (cont.)

**IMPORTANT!** When refilling the cooling system follow these instructions:

- 1) Open petcock at the top of the air compressor
- 2) Fill radiator through the surge tank (5 GPM max)
- 3) Close petcock on air compressor when it begins to flow a steady stream of coolant
- 4) Continue to fill the surge tank until coolant is visible halfway up the sight glass
- 5) Start and run engine at idle for 10 seconds, and then at high idle for one minute
- 6) Return engine to idle and top off surge tank until coolant is visible halfway up the sight glass

## Diesel Exhaust Fluid (DEF)

DEF (diesel exhaust fluid) is used to reduce the NO<sub>x</sub> (nitrogen oxides) emissions from your engine exhaust system. DEF is non-flammable, non-toxic, and non-polluting. DEF can be corrosive to certain materials. If DEF is spilled rinse and clean the area immediately with clear water.

It is recommended that you only use DEF certified by the American Petroleum Institute (API) in your vehicle. Look for this symbol on the container, or dispensing system to identify the fluid has been certified by the API.



DEF has a limited shelf life. Normal shelf life is around 18 months if stored in a sealed container at temperatures between 23°F and 77°F. DEF should not be stored in direct sunlight as this will reduce the shelf life of the product. If your coach is in storage for a period of 6 months or longer you should have the condition of the DEF tested before use. Testing should be done using a DEF refractometer. The DEF should show 32.5% Urea concentration, +/- 1.5%. If the DEF test outside of this parameter the tank should be drained, flushed with distilled water, and filled with new DEF.

DEF consumption will vary depending on your driving habits, and operating conditions. Generally DEF consumption will be 2 to 4 gallons for every 100 gallons of diesel fuel burned.

DEF freezes around 12°F. The DEF system on your vehicle is designed to accommodate this condition and does not require any intervention from the operator.

NEVER add anything other than new or known good DEF to the tank. If the tank is accidentally contaminated by another fluid the tank should be drained, flushed with distilled water, and filled with new DEF.

## Differential Oil

The differential in your coach was factory filled with Shell Spirax 75W-90 full synthetic lubricant. The fluid level should be checked every 10K miles. If make-up oil is required use only full synthetic 75W-90 lubricants. Never mix mineral oils with synthetic lubricants.

The differential oil should be changed every 3 years or 50,000 miles, whichever occurs first.

## Transmission Fluid

The transmission in your coach was factory filled with Shell Spirax S6 A295 synthetic fluid. Spirax S6 A295 is an Allison approved TES-295 fluid. Allison approved TES-295 fluids extend both the service intervals, and the warranty for your transmission. Continued use of TES-295 fluid provides extended warranty coverage up to 5 years or 200,000 miles whichever occurs first.

Transmission fluid should be checked on a regular basis. It is recommended to check fluid at the end of the day when the transmission is at full operating temperature. Fluid should be checked with the park brake set, the engine running at idle, the transmission in neutral, and the transmission temperature above 140°F.

Transmissions do not consume fluid. If you find the need to regularly add fluid to your transmission a leak has developed, and you should seek service from an Allison authorized dealer as soon as possible.

Change the transmission filter every 24 months or 50,000 miles whichever occurs first. Change the transmission fluid every 48 months or 150,000 miles whichever occurs first.

Please refer to your Allison Transmission Operators Manual for additional information on transmission fluids, and other transmission maintenance.

# Lubrication Points (Front)

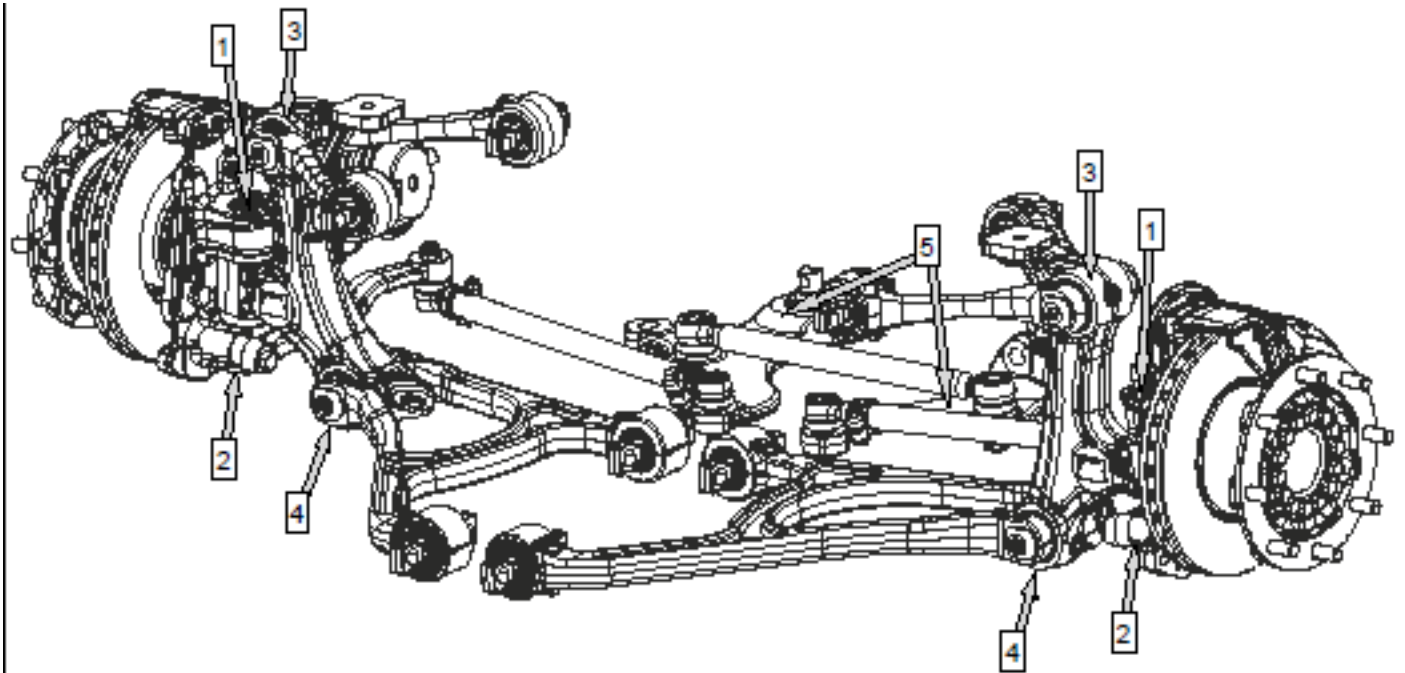

# Lubrication Points

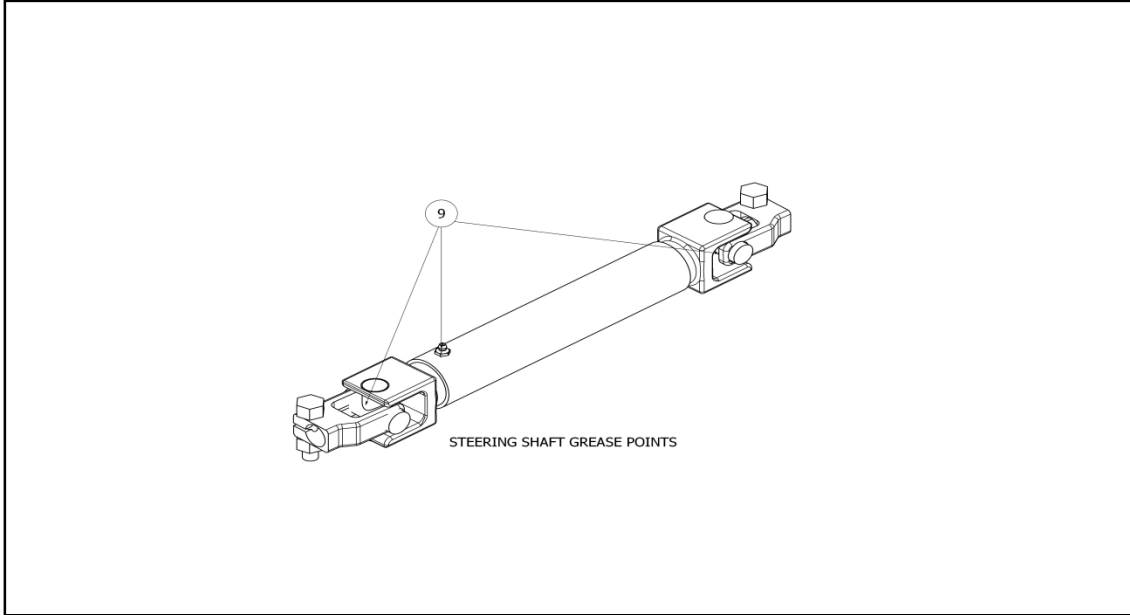

# Lubrication Points

## (Rear)

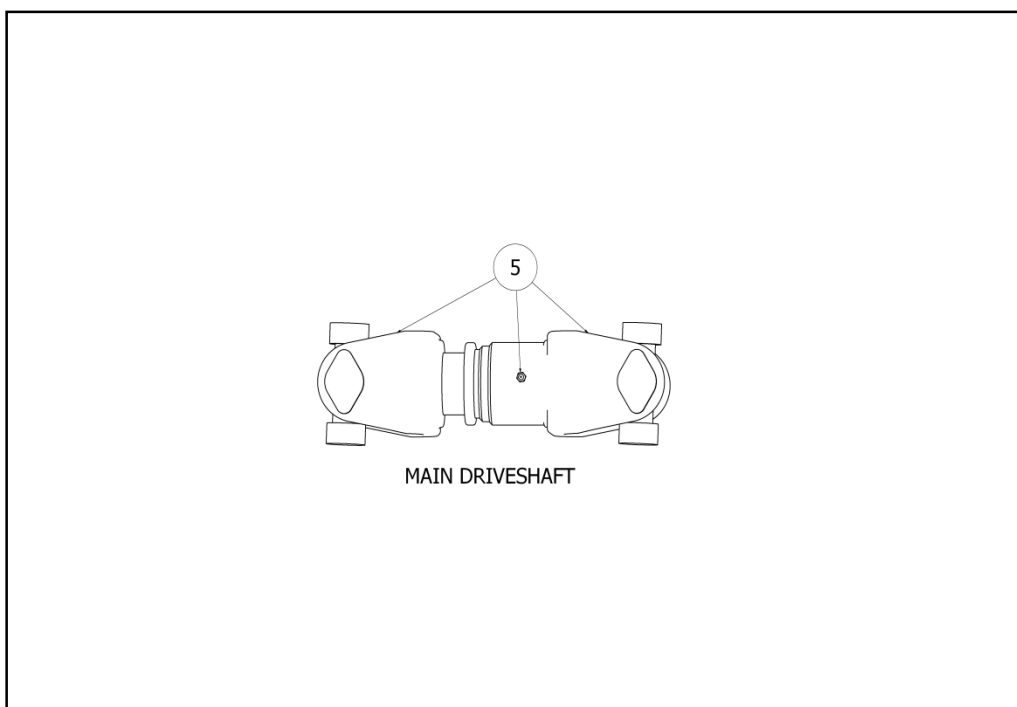
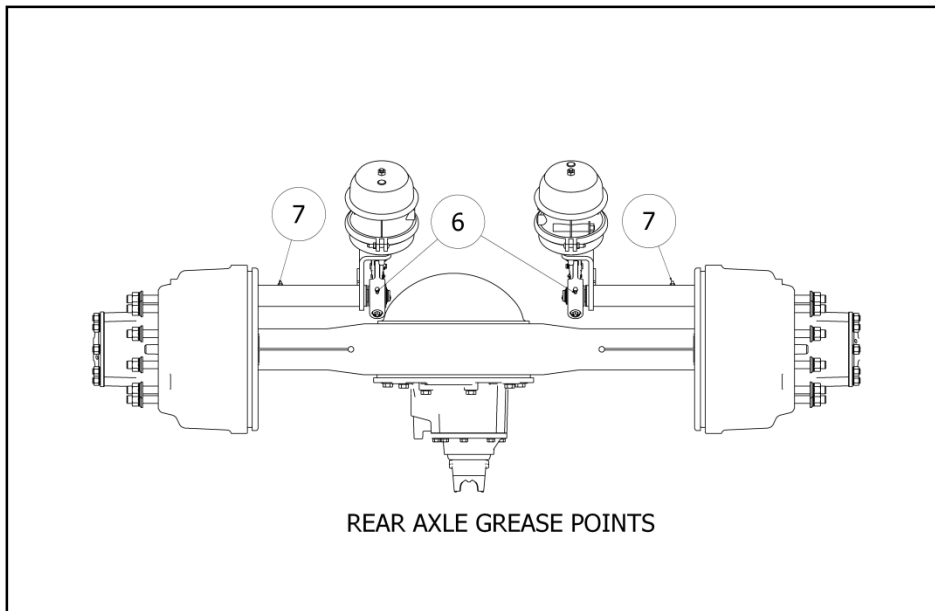

# Lubrication Points

Components	Remarks	Total
Upper / Lower Steering Shafts	Three grease fittings; one at each u-joint, and one at slip joint.	6
Tie Rods	One grease fitting per tie rod. Two on left and two on right tie rods.	4
Main Driveshaft	Three grease fittings; lubricate both universal joints & slip joint.	3
Automatic Slack Adjusters	One grease fitting on each slack adjuster. One adjuster at each wheel end.	4
Brake Camshaft Brackets	One grease fitting on each bracket; Pump in grease until it appears at the slack adjuster end of the bracket. One at each wheel end.	4
Relay Rod	One grease fitting on each rod end.	2
Front Suspension Idler Arm	One on idler arm housing	1



# Maintenance Parts

## Engine Oil Filter

Cummins part # LF3970

Tiffin part # N/A

## Engine Stage 1 Fuel Filter

Cummins part # FS1098

Tiffin part # N/A

## Engine Stage 2 Fuel Filter

Cummins part # FF63009

Tiffin part # 5059830

## Engine Air Filter

Parker / Racor # 062891001

Tiffin Part # 5059543

## Transmission Filter

Allison part #29539579

Tiffin Part # 5018863

## Serpentine Belt

Cummins part # 3978294

Tiffin Part # N/A

**MAINTENANCE**

**For assistance with your  
Tiffin PowerGlide Chassis**

Please contact one of the following  
Chassis Specialists at Tiffin Motorhomes, Inc.

256-356-8661

**Service**

Billy Payne, extension 3862

**Service**

Ricky Brown, extension 3861

**Parts**

Heath Thorne, extension 3860

**Mechanical Engineering**

Corbette Davis, extension 2125

**Electrical Engineering**

Chris Stuzik, extension 2363

**Plant Manager**

Gary Harris, extension 2288

Please have your **Chassis VIN #** ready when you call.

**MAINTENANCE**



## Cummins ISB Engine

---

**Engine Model**  
**ISB6.7 340**

**Advertised HP (kW) @ RPM**  
**340 (254) @ 2600**

**Peak Torque LB-FT (N•M) @ RPM**  
**700 (949) @ 1600**

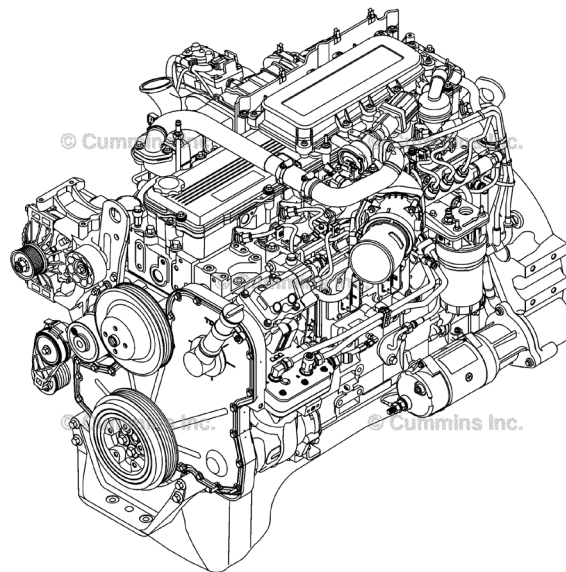

0000018

## EPA Mandates

The Environmental Protection Agency (EPA) mandates that all engines built after December 31, 2009 must reduce the level of emissions exhausted by the engine to the following levels.

Nitrous Oxides (NO<sub>x</sub>) – 0.2 g/bhp-hr

Particulate Matter (PM)- .01 g/bhp-hr

To meet EPA guidelines, diesel engines installed in Tiffin Motorhomes PowerGlide chassis for domicile in Canada and the USA use an after treatment system (ATS) with a diesel particulate filter (DPF) to reduce particulate matter, and selective catalytic reduction (SCR) technology to reduce NO<sub>x</sub> downstream of the engine.

### Notice

Using non-specification fluids can result in serious damage to the ATS. It is extremely important that the following guidelines be met for vehicles with EPA10 thru EPA2017 compliant engines, or damage may occur to the ATS, and the warranty may be compromised.

- Use "ultra-low sulfur diesel (ULSD)" with 15 ppm sulfur content or less.
- Do not use fuel blended with used engine lube oil or kerosene.
- Engine lube oil must have a sulfated ash level less than 1.0 wt %, currently referred to as CJ-4 oil.
- Use only API certified diesel exhaust fluid (DEF) in the DEF tank.



The ATS is comprised of a diesel oxidation catalyst (DOC), and a diesel particulate filter (DPF). The DPF traps soot particles, and exhaust heat converts the soot to ash in the DPF in a process called regeneration (re-gen). The harder an engine works, the better it disposes of soot. When the engine is running under load and re-gen occurs without input, it is called passive re-gen. If the engine isn't running hot enough, the electronic controls may initiate an active re-gen, whereby extra fuel is injected into the exhaust stream before the DPF, to superheat the soot trapped in the filter and burn it to ash. Both types of re-gen occur without driver input.

Operating at reduced engine load will allow soot to accumulate in the DPF. When this occurs, the DPF lamp  illuminates, indicating that a re-gen **must** be performed, and the driver **must** bring the vehicle up to highway speed to increase the load. Driving at highway speeds for 20 minutes should allow for a re-gen to take place, and turn off the DPF lamp.

After the exhaust stream passes through the DPF, it flows through a second canister housing which is the SCR device. A controlled quantity of diesel exhaust fluid (DEF) is injected into the exhaust stream where heat converts it to ammonia (NH<sub>3</sub>) gas. This mixture flows through the SCR device where the ammonia gas reacts with the NO<sub>x</sub> in the exhaust to produce harmless nitrogen (N<sub>2</sub>) and water vapor (H<sub>2</sub>O), which then exits out of the tailpipe.

## ATS Warning Lamps

Warning lamps in the driver's message center alert you of situations with the after-treatment system.

- An illuminated DPF lamp indicates a re-gen is needed.  Driving at highway speeds for 20 minutes should correct this condition.
  - A blinking DPF lamp indicates the need for a re-gen is more urgent. Again, driving the vehicle at highway speeds for 20 minutes should correct this condition.
  - A blinking DPF lamp along with a check engine light indicates that the engine is unable to effectively regenerate, and you should **immediately** seek service at the nearest Cummins Authorized Dealer.
- An illuminated High Exhaust Temperature (HEST) lamp alerts the operator of elevated exhaust temperatures while the engine is performing an active re-gen.  Do not operate, or park the vehicle near flammable objects while the HEST lamp is illuminated.
- An illuminated DEF warning lamp indicates that the DEF tank should be refilled at the next opportunity.  This light will illuminate when the tank level is at approximately 10%.
  - A blinking DEF warning lamp indicates the tank level has dropped to approximately 5%.
  - A blinking DEF lamp along with the check engine lamp indicates the tank level has dropped to approximately 2.5%. A 25% reduction in engine torque will be applied with this condition.
  - When the tank is empty the Stop Engine Light will be illuminated and the vehicle speed will be limited to 5 MPH. Filling the tank with new DEF will remedy this condition.

## DPF Maintenance

Eventually ash will accumulate in the DPF and the filter will require servicing. DPF servicing must be performed by an authorized technician, following the engine manufacturer's instructions. DPF cleaning will be required at approximately 200,000 miles of service. A record must be maintained for warranty purposes, which includes:

- Date of cleaning or replacement
- Vehicle mileage

- Particulate filter part number and serial number

## Aftertreatment Operation

### Diesel Particulate Filter

Soot is composed of the partially burned particles of fuel that occur during normal engine operation (black smoke).

Ash is composed of the partially burned particles of engine oil that occur during normal engine operation.

Over time, both soot and ash accumulate in the DPF and must be removed. Soot is removed by a process called regeneration. Ash is removed by removing the DPF and cleaning it at specified intervals.

A vehicle with an ATS has up to four additional indicator lamps on the dashboard. These additional lamps, along with the check engine lamp, alert the operator of the status of the ATS.

Ultra low sulfur diesel fuel is required for an engine equipped with a DPF. If ultra low sulfur diesel is not used, the engine might not meet emissions regulations, and the DPF or DOC can be damaged.

To maximize the maintenance intervals of the DPF, Cummins Inc. recommends the use of a lubricating engine oil meeting Cummins Engineering Standard 20081. The use of oil meeting CES 20081 also requires the use of ultra low sulfur diesel fuel to maintain the specified oil drain interval without risk of engine damage.

### Regeneration

Regeneration is the process of converting the soot collected in the DPF into ash.

Under some operating conditions, such as low speed, low load, or stop and go duty cycles, the engine may not have enough opportunity to regenerate the DPF during normal vehicle operation. When this occurs, the engine will illuminate the DPF lamp to inform the vehicle operator that assistance is required, typically in the form of operating the vehicle at highway speeds for approximately 20 minutes.

Heat is required for the regeneration process to occur. Regeneration can be classified into two different types: passive regeneration and active regeneration.



## Passive Regeneration

Passive regeneration occurs when the exhaust temperatures are naturally high enough to oxidize the soot collected in the DPF faster than the soot is collected.

Passive regeneration typically occurs when the vehicle is driven at normal highway speeds and/or under heavy loads.

## Active Regeneration

Active regeneration occurs when the exhaust temperatures are not naturally high enough to oxidize the soot in the DPF faster than it's collected.

Active regeneration requires assistance from the engine in to increase the exhaust temperature. This is typically accomplished by the engine injecting a small amount of diesel fuel into the exhaust stream, which is then oxidized by the DOC, and creates the heat needed to regenerate the DPF.

Active regeneration will occur more frequently in vehicles operated at low speed, low load, or stop and go duty cycles. Active regeneration only occurs if the engine ECM has detected that the DPF restriction has reached a specified limit, and may only occur if the vehicle is moving above a preset speed threshold. The engine ECM will activate and de-activate active regeneration as needed.

Active regeneration is largely transparent to the vehicle operator, the vehicle operator may notice an increase in turbocharger noise during an active regeneration event, and may notice that the high exhaust temperature lamp is illuminated, if the vehicle is so equipped.

During active regeneration, the exhaust temperature can be hotter than when the engine is operating at full load. The exhaust temperature during a normal active regeneration event could reach 1100°F, and possibly 1500°F under certain conditions.

## Warning

Active regeneration can occur any time the vehicle is moving, and the exhaust temperature can remain hot after the vehicle has stopped moving. The exhaust temperature could reach 1500°F, which is hot enough to ignite or melt common materials, or to burn people. If the HEST lamp is illuminated do not operate or park the vehicle with the exhaust near people, or flammable materials.

## Aftertreatment Warm-up

The ATS warm up function is used to help prevent the buildup of water condensation in the ATS during extended idle operation.

After approximately four hours of engine idle operation, the engine speed will increase to around 1100 RPM, and remain at this speed for 10 minutes. During this time the ATS is warmed up enough to evaporate any water that has condensed in the system.

The ATS warm-up function can be stopped by depressing the throttle, clutch, or brake pedal. If the engine continues to idle, the ATS warm-up function will try to raise the idle speed until the ATS temperatures are suitable.

## Engine Indicator Lamps

### General Information

The following engine indicator lamps cover only the lamps controlled by the engine ECM.

#### Wait to Start Lamp

The WAIT TO START lamp illuminates when the intake air heater needs to warm the intake air prior to starting the engine. The WAIT TO START lamp on time will vary depending on the ambient air temperature.

The WAIT TO START lamp is amber and looks similar to this:



#### Check Engine Lamp

The CHECK ENGINE lamp illuminates when the engine needs to be serviced at the first available opportunity.

The CHECK ENGINE lamp is amber, and looks similar to this:



Another function of the CHECK ENGINE lamp is to flash for 30 seconds at key-on when one of the following occurs. This flashing function is referred to as the MAINTENANCE lamp. The MAINTENANCE lamp could flash for any of the following reasons:

- Maintenance required (if the Maintenance Monitor is enabled).
- Water-in-fuel is detected.
- Coolant level is low.

## Stop Engine Lamp

The STOP ENGINE lamp indicates, when illuminated, the need to stop the engine as soon as it can be safely done. The engine must remain shut down until the engine can be repaired.

For engines with the Engine Protection shutdown feature enabled, if the STOP ENGINE lamp begins to flash, the engine will automatically shut down after 30 seconds. The flashing STOP engine lamp alerts the operator to the impending shut down.

The STOP ENGINE lamp is red in color, and looks similar to this:



## Malfunction Indicator Lamp (MIL)

The engine in this vehicle is required to conform to EPA Heavy Duty On-Board Diagnostic (OBD) regulations. OBD exist to make sure the engine is operating within the prescribed emissions limits. The OBD system monitors the ATS to detect malfunctions that adversely affect emissions. If a malfunction is detected the malfunction indicator lamp (MIL) will illuminate, and a diagnostic fault code will be logged in the engine control module.

The MIL lamp is amber, and looks similar to this:



## Diesel Particulate Filter (DPF) Lamp

The DPF lamp indicates, when illuminated or flashing, that the DPF needs to be regenerated.

The DPF lamp is amber, and looks similar to this:



An illuminated DPF lamp indicates that the DPF needs to be regenerated at the next possible opportunity. This can be accomplished by:

1. Changing to a more challenging duty cycle, such as highway driving, for at least 20 minutes.
2. Have a Cummins authorized repair location perform a stationary regeneration.

**NOTE:** Stationary regeneration is considered a normal maintenance practice and is not covered by Cummins Inc. warranty.

A flashing DPF lamp indicates that the DPF needs to be regenerated at the next possible opportunity. Engine power may be reduced automatically.

When the DPF lamp is flashing, the operator should:

1. Change to a more challenging duty cycle, such as highway driving, for at least 20 minutes.

2. Have a Cummins authorized repair location perform a stationary regeneration.

A flashing DPF lamp combined with an illuminated CHECK ENGINE lamp indicates that the DPF needs be regenerated immediately. Engine power will be reduced automatically. When these lamps are illuminated together you should **immediately** seek service from a Cummins authorized repair location.

NOTE: If the engine is unable to complete a DPF regeneration cycle, the STOP ENGINE lamp will illuminate and the vehicle will have to be towed to a Cummins authorized repair location.

### High Exhaust Temperature (HEST) Lamp



The HEST lamp is amber, and looks similar to this:

The HEST lamp indicates, when illuminated, that exhaust temperatures are high due to regeneration of the DPF. The lamp could illuminate during normal engine operation or during stationary regeneration.

NOTE: The OEM determines whether or not the HEST lamp is installed on the vehicle. The OEM also specifies the temperatures, vehicle speeds, and other conditions at which the lamp illuminates. Refer to the OEM service manual for additional information regarding this lamp.

When this lamp is illuminated, make sure the exhaust pipe outlet is not directed at any surface or material that will melt, burn, or explode.

- Keep the exhaust outlet away from people, and anything that can burn, melt, or explode.
- Nothing within 0.6 m [2ft] of the exhaust outlet
- Nothing that can burn, melt, or explode within 1.5 m [5ft] (such as gasoline, wood, paper, plastics, fabric, compressed gas containers, or hydraulic lines).
- In an emergency, turn off the engine to stop the flow of exhaust.

**NOTE:** The HEST lamp does not signify the need for any kind of vehicle or engine service; it merely alerts the vehicle operator to high exhaust temperatures, it will be common for the HEST lamp to illuminate on and off during normal vehicle operation as the engine completes regeneration.

### Diesel Exhaust Fluid (DEF) Lamp



The DEF lamp is amber, and looks similar to this:

The DEF lamp indicates, when illuminated or flashing, that the diesel exhaust fluid level is low.

### Diesel Exhaust Fluid (DEF) Lamp (cont.)

An illuminated DEF lamp indicates that the DEF level has fallen below the initial warning level. This can be corrected by filling the DEF tank with diesel exhaust fluid.

**NOTE:** It is recommended that the DEF tank be filled completely full of diesel exhaust fluid in order to correct any fault conditions.

A flashing DEF lamp indicates that the DEF level has fallen below the critical warning level. This can be corrected by filling the diesel exhaust fluid tank with diesel exhaust fluid.

**NOTE:** It is recommended that the DEF tank be filled completely full of diesel exhaust fluid in order to correct any fault conditions.

A flashing DEF lamp combined with an illuminated WARNING or CHECK ENGINE lamp indicates that the DEF level has fallen below the initial derate level. The engine power will be limited automatically. This can be corrected by filling the DEF tank with diesel exhaust fluid.

**NOTE:** It is recommended that the diesel exhaust fluid tank be filled completely full of diesel exhaust fluid in order to correct any fault conditions.

If the engine has been shut down, idled for 1 hour, or if fuel has been added after the DEF tank has been emptied, the STOP ENGINE lamp will also be illuminated along with the flashing DEF lamp and illuminated CHECK ENGINE lamp. The engine vehicle speed will also be limited to 5 mph.

**NOTE:** In order to remove the 5 mph speed limit, the diesel exhaust fluid tank must be filled to at least 10 percent volume of the tank.

**NOTE:** It is recommended that the DEF tank be filled completely full of diesel exhaust fluid in order to correct any fault conditions.

## Engine Starting

### Warning

Do not use starting fluids with this engine. This engine is equipped with an intake air heater. Use of starting fluids could cause an explosion, fire, personal injury, severe damage to the engine, and property damage.

**NOTE:** For cold-weather starting, see “Cold-Weather Operation” in Section 1 of the Cummins Engine Owner’s Manual.

**NOTE:** Cummins electronic engines are run on a dynamometer before being shipped from the factory. They do not require a break-in period.

**IMPORTANT:** Special break-in oils are not recommended for new or rebuilt Cummins engines.

### NOTICE

If a vehicle does not start on the first attempt, make sure that the engine has completely stopped rotating before reapplying the starter switch. Failure to do so can cause the pinion to release and re-engage, which could cause ring gear and starter pinion damage.

**IMPORTANT:** Ring gear and starter pinion damage caused by improper starting procedures is not warrantable.

### NOTICE

Do not crank the engine for more than 30 seconds at a time. Wait two minutes after each try to allow the starter to cool. Failure to do so could cause starter damage.

### NOTICE

If the engine is equipped with a turbocharger, protect the turbocharger during start-up by not opening the throttle or accelerating the engine above 1000 rpm until normal engine idle oil pressure registers on the gauge.

## Starting

Set the parking brake.

1. Place the transmission in neutral.
2. Turn the key to the ON position.
3. Wait a minimum of 10 seconds. If the “Wait-to-Start” lamp is still illuminated after 10 seconds, continue to wait until the lamp is no longer illuminated. The wait to start lamp may stay illuminated for up to 30 seconds depending on ambient temperature.
4. Start the engine.
5. NOTE: See the Cummins Operation and Maintenance Manual for detailed information on starting procedures.

## Cold-Weather Starting

Turn the ignition switch to the on position. If the Wait-To-Start lamp  is illuminated, wait until it goes out before trying to start the engine. The Wait-To-Start lamp will stay on for up to 30 seconds. The length of time it remains illuminated depends on the ambient temperature. Once the Wait-To-Start lamp goes off, turn the key to the start position. If the engine doesn't start after 30 seconds of cranking, turn the key to the off position and wait two minutes; then repeat the starting procedure. Once the engine is started, let it run at idle for 3 to 5 minutes before driving. If normal engine oil pressure doesn't show on the gauge within 15 seconds of starting, shut the engine off and contact your nearest Cummins authorized repair location for assistance.

If the unit is equipped with a block heater, start the block heater 2 to 4 hours before travel.

## Engine Braking

**Important:** The engine brake is a vehicle slowing device, not a vehicle stopping device. It is not a substitute for the vehicle service brakes. Use of the engine brake for vehicle downhill control, and slowing down on level terrain will help the service brakes to remain cool and ready for an emergency. Engine braking is covered thoroughly in section 3.

## Warning

Do not use the engine brake on wet, icy, or snow-covered roads. Using the engine brake could result in loss of vehicle control, possibly causing personal injury, death, or property damage.

## Cruise Control

### Warning

Do not use the cruise control system when driving conditions do not permit maintaining a constant speed, such as in heavy traffic or on roads that are winding, icy, snow covered, slippery, or roads with a loose driving surface. Failure to follow this precaution could cause a collision or loss of vehicle control, possibly resulting in personal injury, death, or property damage.

## NOTICE

Cruise control allows you to automatically control the speed of the vehicle above 32 MPH (50 km/h).

Do not shift to Neutral (N) when using cruise control. This will cause the engine to over-speed, which can damage the engine.

### Cruise On/Off

Press the cruise control ON/OFF switch to activate the cruise control or to turn it off.

### Cruise Set

Press the cruise control SET switch to set the desired cruising speed.

### Cruise Resume

Press the cruise control RESUME switch to resume cruise control activation.

### Disengage Cruise



Disengage the cruise control by depressing the service brake, or by switching the cruise on/off switch to the off position.

## Engine Shutdown

1. With the vehicle stopped, place the transmission in the Neutral (N) position, and set the parking brake using the parking brake control knob.
2. It is important to idle an engine for 3 to 5 minutes before shutting it down. This allows the lubricating oil and the water to carry heat away from the combustion chambers, bearings, shafts, etc. This is especially important with turbo-charged engines.
3. Do not idle the engine for long periods.
4. If the engine is not being used, shut it down by turning the ignition key to the OFF position.
5. Allow a minimum of 3 minutes after the engine is turned off before switching off the chassis battery disconnect.

## Diagnostic Fault Codes

The engine control (ECM) monitors the engine sensors and parameters while the engine is in operation. The ECM can detect certain conditions that are outside of the normal operating parameters. The ECM will log diagnostic fault information, and illuminate the check engine light, stop engine light, or the malfunction indicator light to inform the operator of a problem. It will also log diagnostic fault information in the form of numeric codes to assist a technician in troubleshooting the concern.

Diagnostic fault codes fall into two categories; active faults, and historic faults. Active faults indicate the condition causing the fault is still present. Historic faults indicate the condition causing the fault is no longer present, but remain in the ECM memory to assist the technician when diagnosing the concern.

Active fault codes can be retrieved by the operator using the dash instrumentation. This can be helpful in determining if the condition is serious, and needs immediate attention, or if it is safe to continue operating the engine until it is convenient for the operator to have the service work performed.

Retrieve active fault codes using the following steps:

Refer to page 40 in the Instruments & Controls chapter of this manual, follow the instructions on page 34 and navigate to the OBD section and retrieve the information listed below.

The desired screen will look like this:

On Board Diagnostics (DM1)		
Status	SPN	FMI ADDR Description
Active	96	3-Volt Above Norm 33 Fuel Level 1
Inactive	241	18-Data Below Norm MS 51 Tire Pressure

Two pieces of information will be displayed

- a. SPN followed by a 3 or 4 digit number
- b. FMI followed by a 1 or 2 digit number

Provide these two pieces of information to a Tiffin phone tech, or the nearest Cummins authorized repair location for guidance on how you should proceed.

## Towing

The Allegro Breeze is capable of towing typical motor vehicles or trailers up to 5,000 lbs. The motor home is equipped with a towing hitch, and associated wiring connector. The total weight of the motor home and any vehicle towed must not exceed the Gross Combined Weight Rating (GCWR). When the motor home is weighed, remember to account for passengers and their locations in the motor home. Any vehicles or trailers to be towed by the motor home should have adequate active braking.



# Allison Transmission Operation

---

## Operation

The Allegro Breeze with the Powerglide Chassis is equipped with an Allison 2100MH transmission.

The display screen on the shift control pad will indicate the highest selected gear for the transmission. When mountainous or up-and-down terrain conditions are encountered, you should **manually select a lower gear**, preferably lower than 5<sup>th</sup> gear. This can be done at any road speed by pressing the down arrow repeatedly until the desired gear is indicated in the window of the shifter pad. When your road speed decreases to a safe point, the transmission will downshift at a higher **RPM** than normal. This will decrease the use of overdrive while pulling hills, which can result in excessive heat build-up in the transmission, and keeps the engine operating at peak horse power and performance.

When ascending a grade, maintain engine speed to within **400-500 RPM** of governed engine speed. Governed speed will be **2800 RPM** on the Cummins ISB engine model. Road speed may decrease, but the engine will be at its peak in the power curve.

It is especially pertinent to monitor your water temperature gauge when climbing steep grades. Keep in mind that it is not uncommon for the temperature to increase, especially in hot weather. If the gauge reaches 225°F or if the temperature warning light on the gauge panel should come on, reduce your road speed, shift to the next lower gear and keep your tachometer within **500 RPM** of engine governed speed. In many cases this will stabilize the water temperature. If the temperature gauge continues to rise, or if the stop engine light comes on, pull to the side of the road and shift the transmission into neutral. Bring the engine **RPM** to **1,700—2,000 RPM** until the temperature drops down into the normal range. This should occur in a relatively short period of time. If the temperature gauge does not begin to drop, stays in the red zone, or continues to rise, shut down the engine and allow it to cool. After the engine is allowed to cool check the fluid level in the reservoir and add coolant if needed.

A good “**rule of thumb**” for descending grades is to never use a higher gear than was used to climb the same or similar grade. Try to keep the engine within **500 RPM** of governed speed. This will give the best engine braking and reduce the need to use the service brakes. Select a gear that will keep you at a safe speed with minimal brake application. Never ride your brakes when descending a grade since excessive brake heat will build up and your brakes could fade, leaving you with little or no braking power.

Your vehicle is equipped with an engine brake. The engine brake will assist in slowing your vehicle on a downhill grade. With the engine brake switch in the on position, release the accelerator and depress the service brake to activate the engine brake. When the engine brake is activated the transmission will pre-select a lower gear to aid in braking. This is indicated by a “2” in the left hand pane of the transmission shift selector. The transmission will begin to down-shift as soon as the road and engine speed will safely allow. This will produce a slowing effect and will remain engaged until either the exhaust brake switch is turned off, the accelerator is pressed, or the engine speed drops to 800 RPM. If your initial speed is high, you may have to step on the brake to slow the vehicle before the transmission will down-shift from 6<sup>th</sup> gear to 5<sup>th</sup> gear. This is normal.

Always select (**N**) neutral on the transmission shift pad prior to turning off the vehicle engine.

## Fluid Level Check

Use the transmission dipstick for best results in checking the transmission fluid level. The transmission will not reach operating temperature until the coach has been driven for at least 15 miles. Therefore, it may be best to check transmission fluid level at the end of your driving day.

Transmissions **do not** consume fluid. If your transmission shows to be low of fluid, it should be inspected for leaks.

The dipstick is marked with temperature bands for a COLD and HOT fluid level check. The fluid check marked COLD is designed to allow the fluid level to be checked from 61-140°F (16-60°C). The fluid check marked HOT is designed to allow the fluid level to be checked from 160-220°F (71-104°C).

Check the transmission fluid level with the following steps (**HOT CHECK PROCEDURE**):

**Conditions that must be met for checking transmission fluid with the dipstick:**

- Be sure transmission is at operating temperature (104° to 220° F)
- Vehicle is parked on level ground with the parking brake is set
- Transmission in neutral and park brake applied
- Engine is at low idle
- Wait until vehicle has been stationary for two minutes
- With the engine running, remove the dipstick from the tube and wipe the dipstick clean
- Insert the dipstick into the tube and remove. Check the fluid level reading. Repeat the check procedure to verify the reading.

# Instruments & Controls

---



# **GRAPHICAL INSTRUMENT CLUSTER**

---

## **OPERATION MANUAL**

VDC00463

**TIFFIN, LEVELING, 12.3" DISPLAY, AIR ONLY**



Rev - 20-Apr-20 MW

Copyright © 2020 Valid Manufacturing Ltd. All rights reserved.

Information in this document is subject to change without notice. No part of this document may be reproduced or transmitted, in whole or in part, in any form, or by any means, electronic or mechanical, for any purpose, without the express written permission of Valid Manufacturing Ltd.

# CONTENTS

Safety Instructions.....	4	TPMS (Tire Pressure Monitoring System) .....	18
Warning.....	4	Information Gauges.....	19
Caution.....	4	Leveling .....	20
Overview .....	5	Pre-Drive .....	21
Cleaning your GIC screen .....	5	ACC (if equipped) .....	21
Gauge Quick Reference .....	8	Brightness .....	22
Navigation .....	9	Settings .....	22
Joystick Knob.....	9	Additional Displays.....	23
Indicators.....	10	CMS (if equipped).....	23
Main Gauges .....	14	Mobileye® (if equipped).....	23
Engine Coolant Temperature.....	14	Leveling .....	24
Engine Oil Pressure.....	14	More .....	24
Speedometer .....	14	Auto Level Mode.....	24
Fuel Level – Engine & Generator .....	15	Travel Mode .....	26
Message Center .....	15	Alarm Messages – Information.....	27
Trip Meter/Fuel Economy .....	16	Alarm Messages – Caution .....	28
Tachometer .....	16	Alarm Messages – Critical .....	31
Diesel Exhaust Fluid (DEF) Level.....	16	Menu Map – Selectable Display Menu.....	32
Chassis Battery Voltage .....	17	Menu Map – Settings Menu .....	34
Front and Rear Air Tank Pressure .....	17	Menu Map – Tire Pressure (TPMS) Setup Menu .....	35
Compass.....	17	Tire Pressure (TPMS) Sensor Display .....	36
Outside Temperature .....	17	Tire Pressure (TPMS) Configuration .....	37
Time .....	17	Diagnostics .....	40
Selectable Display.....	18		
Trip 1, Trip 2 and Fuel Economy.....	18		

# SAFETY INSTRUCTIONS

## Warning

---

- Driving while distracted can result in loss of vehicle control.
- Do not make adjustments in the selectable display on the graphical instrument cluster under conditions that will affect your safety or the safety of others.

## Caution

---

- Your graphical instrument cluster system should be serviced only by qualified personnel.

# OVERVIEW

The Graphical Instrument Cluster (GIC) is a display device that communicates electronically with multiple pieces of equipment on the coach.

To familiarize yourself with the indicators and gauges, refer to the quick reference guide on pages 6 and 8.

The display will automatically dim for nighttime driving when the headlights are activated.

Selectable displays within the speedometer and tachometer gauges provide a menu system which is navigated by rotating and pressing a joystick knob. Refer to page 33 for the menu selections:

- Speedometer
- Display brightness
- Pre-drive item reminders
- Selectable gauges
- Tire pressure and temperature for coach & trailer
- Trip 1 and Trip 2
- Leveling (if equipped)
- Adaptable Cruise Control (if equipped)

With the coach stopped and the park brake applied, the <Settings> menu also provides the following items:

- Choice of towable trailer/vehicle for the tire pressure monitoring system (TPMS).
- Sound volume for alerts.
- Measurement units for speed/distance, temperature and pressure.
- Background image and brightness.
- Graphics scheme.
- Gauge needle color.
- Vertical position of screen display.
- Diagnostics for system, onboard diagnostics (OBD) and controller area network (CAN-Bus).

## Cleaning your GIC screen

---

The glass on the GIC screen is treated with an optical coating to prevent glare and reflection. It should be cleaned with a product that is designed for this, such as the optical wipes included with the screen, or optical cleaner and a microfiber cloth.

**WARNING:** *The screen surface can be damaged if not treated with care.*

# INDICATOR QUICK REFERENCE



ID	Symbol	Description	Page
1		High Engine Coolant Temp	10
2		Low Engine Oil Pressure	10
3		Left, Right Turn Signal	10
4		Seat Belt	10
5		Headlights High Beam	10
6		Park Brake On	10
7		High Exhaust Temperature	10
8		Diesel Particulate Filter	11
9		Engine Brake	11
10		Electronic Brake Controller	11
11		Anti-Lock Brake System	11
12		Check Transmission	11
13		High Transmission Oil Temp	12
14		Info, Caution or Critical Alarm	12
15		Adaptive Cruise Control	12

ID	Symbol	Description	Page
16		Collision Mitigation System	12
17		Wait to Start	12
18		Automatic Traction Control	12
19		Cruise Control	12
20		Jacks Down	12
21		Low Fuel	12
22		Water in Fuel	12
23		Malfunction Indicator	12
24		Check Engine	12
25		Stop Engine	12
26		Tag Axle Dumped	12
27		DM1 Fault	13
28		Low Diesel Exhaust Fluid	13
29		Low Battery	13
30		Low Tire Pressure	13

# INDICATOR QUICK REFERENCE

ID	Symbol	Description	Page
31		Low Secondary (Front) Tank Air Pressure	13

ID	Symbol	Description	Page
32		Low Primary (Rear) Tank Air Pressure	13

# GAUGE QUICK REFERENCE

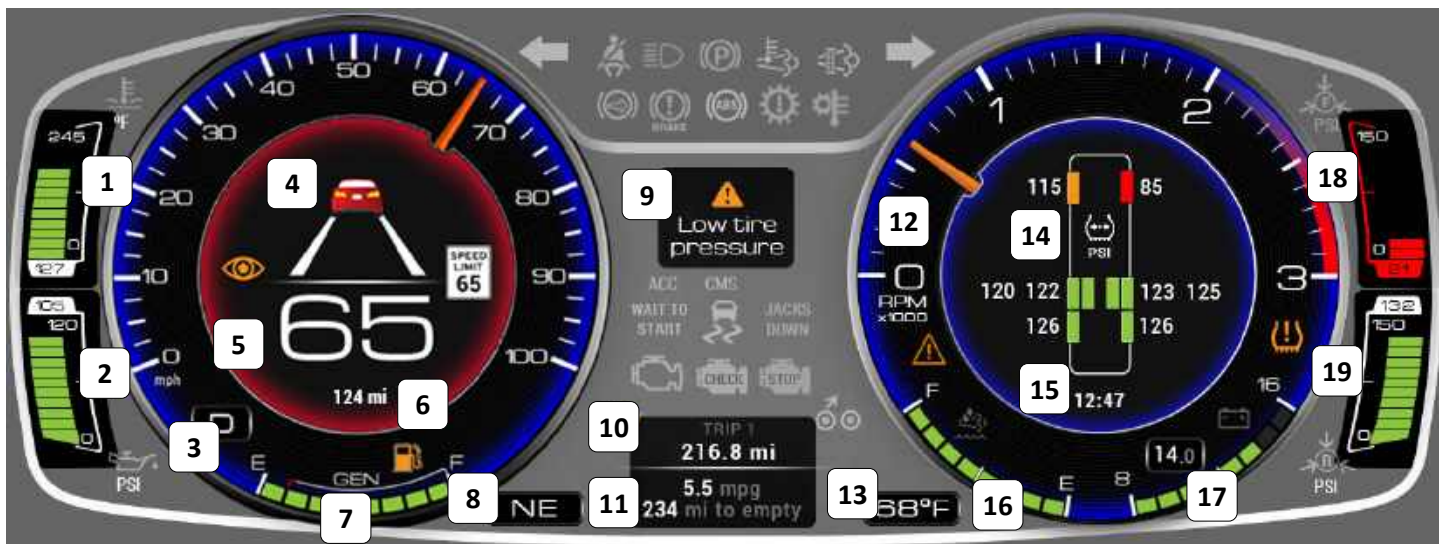

ID	Description	Page #
1	Engine coolant temperature	14
2	Engine oil pressure	14
3	Current gear	14
4	Mobileye®/Collision Mitigation System	
5	Speedometer	14
6	Odometer	14
7	Fuel level	15
8	Compass	17
9	Message center	15
10	Trip meter	16
11	Fuel economy	16
12	Tachometer	16
13	Outside temperature	17
14	Informational display - selectable	18
15	Time	17
16	Diesel exhaust fluid (DEF) level	16
17	Chassis battery voltage level	17
18	Front air tank pressure	17
19	Rear air tank pressure	17

## Joystick Knob

The joystick knob is connected directly to the GIC and is primarily used to navigate the selectable display by **rotating** the knob to scroll the menu or view and **pressing** to select that item (refer to page 18).

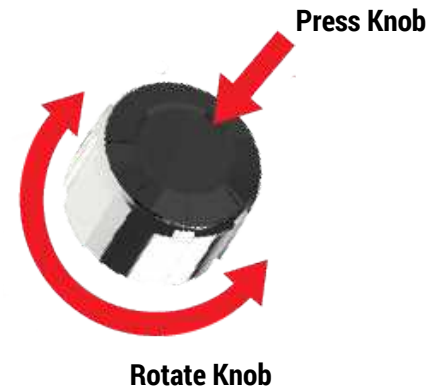





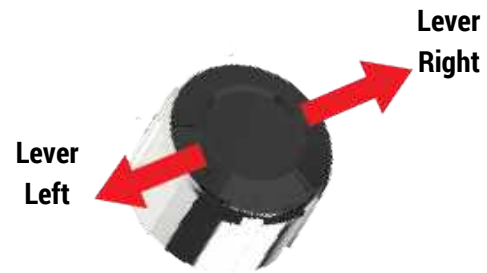

In addition to being pressed or rotated, the top can be levered sideways to the left or right.

Unless your vehicle is equipped with Mobileye® or CMS, it is possible to toggle between the selectable displays for the speedometer and tachometer using the lever action.













# INDICATORS













ID	Indicator	Name	Description
1		High Engine Coolant Temp	A high engine coolant temperature may indicate that your engine is overheating or that you could be losing coolant. Seek service.
2		Low Engine Oil Pressure	Low engine oil pressure can cause engine damage. Stop driving and seek service at the first opportunity.
3		Left, Right Turn Signals	Displays when the left or right turn signal is activated. Both left and right indicators display when Hazard Flasher activated.
4		Seat Belt	After ignition, the seat belt light will flash momentarily.
5		Headlights High Beam	Headlights are in high beam mode.
6		Park Brake On	The park brake is applied.
7		High Exhaust System Temperature (HEST)	Indicates that high exhaust temperatures may exist due to <u>active regeneration</u> (soot burn-off) in the diesel particulate filter (DPF). This is normal and does not signify the need for any kind of vehicle or engine service. When this lamp is illuminated, ensure that the exhaust pipe outlet is not directed at any combustible surface or material.

(Continued on next page)









# INDICATORS

ID	Indicator	Name	Description				
8		Diesel Particulate Filter (DPF)	<p>The exhaust diesel particulate filter (DPF) has excessive soot levels and requires passive or active regeneration (regen) to burn off the soot to prevent a clogged filter.</p> <p>Passive regeneration occurs when the vehicle is driven at a challenging duty cycle, such as highway driving for at least 20 minutes, to increase exhaust temperatures.</p> <p>Active regeneration supplements soot burn-off by injecting diesel fuel to increase exhaust temperature.</p>				
			<b>INDICATORS</b>				
			<b>DPF</b> 	<b>Check Engine</b> 	<b>Stop Engine</b> 	<b>Soot Level</b>	<b>Action Required</b>
			<b>Solid</b>	-	-	Low	Provide regen opportunity:
			<b>Flashing</b>	-	-	Medium	<ul style="list-style-type: none"> <li>➤ Alter duty cycle.</li> <li>➤ Initiate a parked manual regen.</li> </ul>
			<b>Flashing</b>	<b>Solid</b>	-	High	<p>Provide regen opportunity:</p> <ul style="list-style-type: none"> <li>➤ Initiate a parked manual regen.</li> <li>➤ Seek service.</li> </ul>
-	-	<b>Solid</b>	Extreme	<ul style="list-style-type: none"> <li>➤ Stop engine at earliest opportunity.</li> <li>➤ Seek service.</li> </ul>			
9		Engine Brake	The vehicle's engine exhaust brake system is enabled. The exhaust brake is more effective in the lower gears and at higher engine speeds.				
10		Electronic Brake Controller	The Electronic Brake Controller has detected a fault.				
11		Anti-lock Brake System	The electronic brake controller has detected a fault with the anti-lock brake system (ABS) and has disabled this feature.				
12		Check Transmission	Transmission over temp / Check transmission.				

# INDICATORS

ID	Indicator	Name	Description
13		High Transmission Oil Temp	Indicates that the engine oil temperature is higher than the warning level threshold.
14		Info Alarm	Refer to page 27 for a list of INFORMATION alarms.
		Caution Alarm	Refer to page 28 for a list of CAUTION alarms.
		Critical Alarm	Refer to page 31 for a list of CRITICAL alarms.
15	<b>ACC</b>	ACC Mode	Adaptive Cruise Control Mode (green=active; amber=available or disabled; red=error). See page 21 for more information.
16	<b>CMS</b>	CMS Mode	Collision Mitigation System Mode (green=active; amber=available or disabled; red=error). See page 23 for more information.
17	<b>WAIT TO START</b>	Wait to Start	The vehicle's glow plugs must heat up before the vehicle is started. This indicator will remain lit until the glow plugs are ready (approximately 15 seconds, or longer in colder weather). Once the indicator is off, the vehicle can be started.
18		Automatic Traction Control	The electronic brake controller (EBC) has detected a fault with the automatic traction control (ATC) and has disabled this feature.
19		Cruise Control	Cruise control is active – a fixed vehicle speed is set by the operator.
20	<b>JACKS DOWN</b>	Jacks Down	If any of the hydraulic jacks are not fully stowed (no matter what gear the vehicle is in), this indicator will be displayed along with a critical alarm message.
21		Low Fuel	Fuel level is below the low fuel threshold.
22		Water in Fuel	Water has been detected in the fuel supply.
23		Malfunction Indicator	Malfunction related to the emissions control system. The after-treatment system should be diagnosed and serviced at your next available opportunity.
24		Check Engine	Scheduled maintenance due. It will flash for 30 seconds after engine ignition and remain illuminated, indicating that the engine needs service at the first available opportunity.
25		Stop Engine	The vehicle must be stopped as soon as it is safe to do so.
26		Tag Axle Dumped	Tag axle weight has been reduced.

# INDICATORS

ID	Indicator	Name	Description				
27		DM1 Fault	Indicates an active diagnostic trouble code.				
28		Low Diesel Exhaust Fluid	This symbol indicates that the diesel exhaust fluid (DEF) is low. The fluid creates a catalytic reaction that removes particles from the exhaust. When low, the fluid must be topped up.				
			INDICATORS				
			DEF	Check Engine	Stop Engine	Fluid Level	Action Required
							
			<b>Solid</b>	-	-	Low	Refill the diesel exhaust fluid (DEF) tank.
<b>Flashing</b>	-	-	Critical				
<b>Flashing</b>	<b>Solid</b>	-	Critically Low	Engine power loss will occur. This will be restored after refilling the DEF tank.			
<b>Flashing</b>	<b>Solid</b>	<b>Solid</b>	Empty	The vehicle will be limited to a speed of 5 mph (8 km/h). Normal engine power and vehicle speed will be restored after refilling the DEF tank.			
29		Low Battery	The battery indicator turns red when the voltage goes below a set level.				
30		Low Tire Pressure	The tire pressure monitoring system (TPMS) has indicated there is a tire with low pressure. Rotate the joystick knob to view coach and trailer tire pressure screens on the selectable display. Press the knob to switch between tire pressure and tire temperature.				
31		Low Secondary (Front) Tank Air Pressure	Pressure in the front (secondary) air tank is low.				
32		Low Primary (Rear) Tank Air Pressure	Pressure in the rear (primary) air tank is low.				

# MAIN GAUGES

## Engine Coolant Temperature

This gauge measures the temperature of the engine coolant fluid.

The message center will display a warning and sound an alert when the temperature is higher than the red warning level.



Green - Normal



Orange - High



Red - Warning

## Engine Oil Pressure

This gauge measures the pressure of the engine oil, which is required to ensure efficient lubrication of the internal engine parts. The oil pressure will increase as the engine RPM is increased from idle to normal driving speed. An oil pressure warning is an indication to seek service at the earliest opportunity.

The message center will display a warning and sound an alert when the pressure is less than the red warning level.

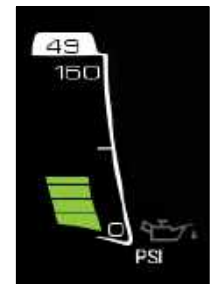

Green - Normal

## Speedometer

The speedometer displays the speed of the vehicle in miles or kilometers per hour, both with a needle and as a digital readout.

Also found on the speedometer is the fuel gauge, generator gauge, cruise control indicator, current gear, and odometer.

With the coach stopped and the park brake applied, you can change the display units between miles and kilometers with the Selectable Display selection *Settings > Units > Speed / Dist.*

The color of the gauge needle can be configured in *Settings > Needle Color.*

### Cruise Control

The Cruise Control indicator is gray when the feature is enabled. It is green when the feature is active and a fixed vehicle speed has been set by the operator.

### Odometer

The odometer displays the lifetime mileage of the vehicle from when it was manufactured.

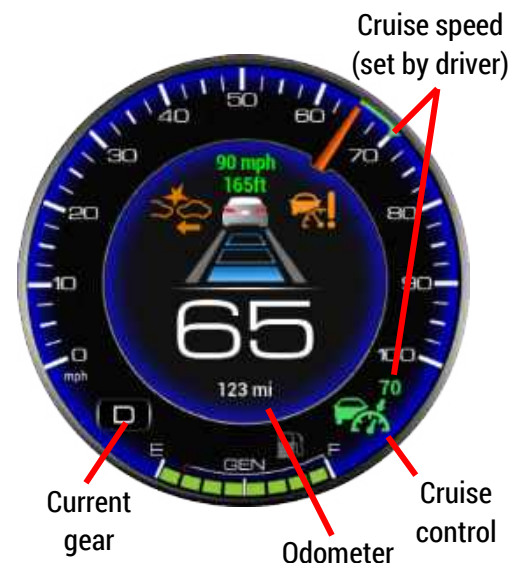

Note: The center display may not appear as shown, depending on how your vehicle is equipped.

# MAIN GAUGES

## Fuel Level – Engine & Generator

The fuel level is displayed at the bottom of the speedometer. When fuel falls below the factory programmed low level, the fuel indicator will turn red and an alert will sound. The generator gauge is a static gauge that indicates the point at which the generator will run out of fuel.

The GIC is connected directly to the fuel tank level sender. Provided the chassis battery level is greater than the factory-configured 'Power Off' level, it continues to send fuel level messages over the RV-C network with the ignition off. This allows the fuel level to be viewed on the Coach Management System for operation of the coach generator.

Note that the generator will run out of fuel before the engine does. As indicated on the gauge, the generator will stop running while there is still an eighth of a tank of fuel left. This provides the operator with the opportunity to drive to a fuelling station.



Fuel level normal



Fuel level low – generator will run out of fuel

## Message Center

The message center is between the speedometer and the tachometer. During normal operation, this area displays the vehicle logo. When necessary, the message area shows three categories of alarms:



**INFORMATION:** These relate to normal operation of the coach. Refer to page 27.



**CAUTION:** These indicate items which require your attention. Refer to page 28. A chime may also sound when an alarm occurs.



**CRITICAL:** These indicate items which require your immediate attention. Refer to page 31. A chime may also sound when an alarm occurs.

When an alarm occurs, it is immediately displayed. After a short delay, the display will then continue to cycle through each active alarm.

# GAUGES

## Trip Meter/Fuel Economy

Trip 1 or Trip 2 are items in the Selectable Display. Rotate the knob to display the item. Press the knob to switch between Trip 1 and Trip 2. Hold the knob to reset. Refer to the menu map on page 33.

The average fuel economy and distance to empty can be configured in miles or kilometers. This changes the display between miles per gallon / miles and liters per 100 kilometers / kilometers. Refer to the menu map: *Settings > Units > Speed / Dist.*

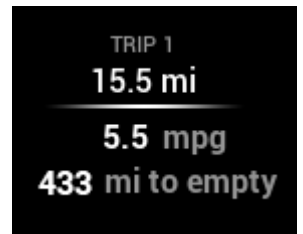

Average fuel economy  
Distance to empty

## Tachometer

The gauge displays engine revolutions per minute (RPM).

The color of the gauge needle can be configured in *Settings > Needle Color.*

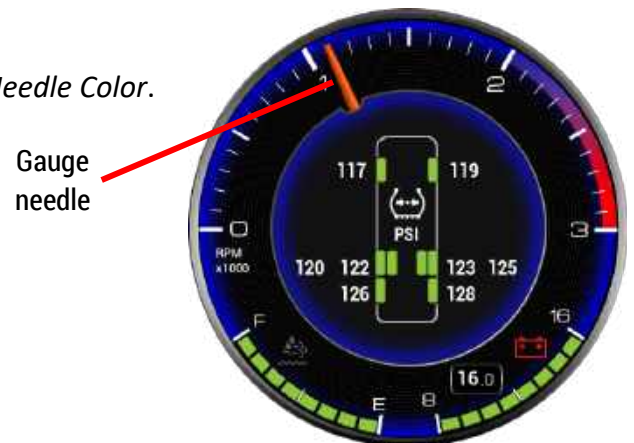

## Diesel Exhaust Fluid (DEF) Level

The diesel exhaust fluid (DEF) level is displayed on the lower left of the tachometer. When the DEF level falls below the factory-programmed low level, the DEF indicator will turn amber and an alert will sound.

The low Diesel Exhaust Fluid (DEF) indicator is illuminated by a message from the engine controller. It has four low level thresholds which determine if the DEF indicator is solid or flashing. Refer to the description on page 13.

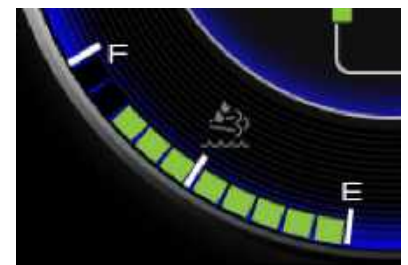

# GAUGES

## Chassis Battery Voltage

This gauge measures the chassis batteries, which are used when driving the coach; for example, starting the engine.

When the voltage falls below 11.5V, the battery indicator will turn red and an alert will sound.

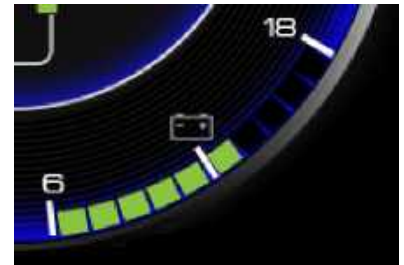

## Front and Rear Air Tank Pressure

The bar gauge color on the front and rear air pressure gauges indicates the following levels:

- Green is normal.
- Orange is slightly low.
- Red is critically low. A warning sound will also occur.

The front air pressure gauge is shown; however, the levels are the same for the rear air pressure gauge.

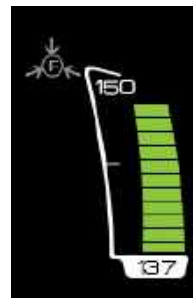

Green - High

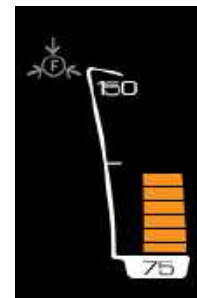

Orange - Low



Red - Warning

## Compass

The compass displays the direction in which the vehicle is heading.



## Outside Temperature

The outside temperature is displayed according to data collected by either RVC (Spyder) or the engine ECU. Units can be changed from Fahrenheit to Celsius in the Settings menu (see page 34).

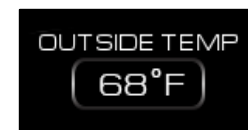

## Time

The time is displayed in the selectable display area of the tachometer.

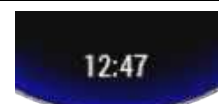



# SELECTABLE DISPLAY

The center of the tachometer can display a variety of information as desired by the user. This information can be selected with the use of the joystick knob. Rotate the knob clockwise and counter-clockwise to scroll up and down the menu items. Press the top button to select that menu item.

The following information is available:

- Trip information (Trip 1, Trip 2, fuel economy)
- TPMS (Tire Pressure Monitoring System)
- TPMS Trailer (if enabled)
- Information Gauges
- Leveling
- Pre-Drive List
- Adaptive Cruise Control (if equipped)
- Brightness
- Settings

Refer to the menu maps on pages 33 & 35 for all available menu options.

## Trip 1, Trip 2 and Fuel Economy

The fuel economy is calculated by the engine controller. 'Inst. Economy' is the instantaneous fuel economy of the vehicle. For example, when driving uphill, a higher value will be displayed than when driving downhill.

Note: Refer to page 16 for information on the the average fuel economy display.

With the coach stopped and the park brake applied, you can also change the display units between miles and kilometers with the Selectable Display selection *Settings > Units > Speed / Dist.*

Note: With miles selected, fuel information displayed in US gallons and miles per gallon. With kilometers selected, fuel information is displayed in liters and in liters per 100 kilometers.

## TPMS (Tire Pressure Monitoring System)

**Tire Pressure** is an item in the Selectable Display. Rotate the knob to display the item. Press the button to toggle between tire pressure and tire temperature.

If the GIC has been configured for towing a trailer (see page 37), the trailer tire pressure is also available in the Selectable Display. Rotate the knob to display the item.

To view TPMS information, hold the rotary knob for 5 seconds to display the TPMS information screen. Refer to page 36 for more information.

Press knob to make selection



Rotate knob to scroll up and down



Press knob to toggle between Trip 1 & Trip 2

# SELECTABLE DISPLAY

The status of each tire is represented by a color.

## Pressure

- Critical High: █ (Red)
- Normal : █ (Green)
- Warning Low: █ (Orange)
- Critical Low: █ (Red)

## Temperature

- High : █ (Red)
- Normal: █ (Green)

The thresholds for pressure and temperature are set at the factory. However, the pressure thresholds are around the 'normal' pressure which is established when the pressure sensor is screwed onto the tire valve.

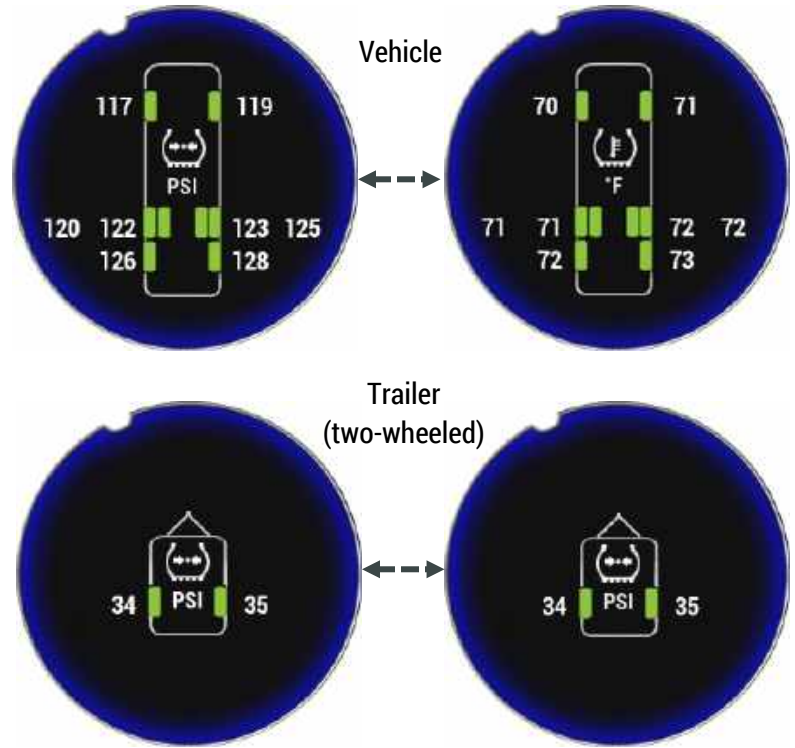

Press knob to toggle between pressure and temperature

## Information Gauges

Information gauges do **not** have any warning threshold levels.

You may choose to display a single gauge, or select the <Scan> item to continuously scan through each gauge every five seconds. Scan mode is indicated by the symbol:

Gauge	Description
<b>Accelerator Position</b>	Displays the position of the accelerator foot pedal. 100% is fully depressed.
<b>Engine Load</b>	At any given speed the engine has a maximum torque rating. Engine load is the current output torque as a ratio of this maximum torque.
<b>Transmission Shaft Speed</b>	Displays the revolutions-per-minute (rpm) of the transmission shaft (drive shaft) which is the output of the transmission (gearbox). Note: The tachometer (refer to page 16) displays engine drive shaft RPM, which is the input to the transmission (gearbox). The difference relates to the current gear selection.

## SELECTABLE DISPLAY

Gauge	Description
<b>DEF Temperature</b>	Displays the temperature of the fluid in the Diesel Exhaust Fluid (DEF) tank. During vehicle operation, Selective Catalytic Reduction (SCR) systems are designed to provide heating for the Diesel Exhaust Fluid (DEF) tank and supply lines. If DEF freezes when the vehicle is shut down, startup and normal operation of the vehicle will not be inhibited. The SCR heating system is designed to quickly return the DEF to liquid form and the operation of the vehicle will not be impacted. The freezing and unthawing of DEF will not cause degradation of the product.
<b>Transmission Temperature</b>	Displays the transmission oil temperature.
<b>House Batteries</b>	The house batteries provide power to interior lights and appliances, thermostats, water pump, etc. They are charged by the engine alternator, generator or shore power. Refer to page 17 for information on the chassis battery gauge.
<b>Generator</b>	Indicates whether the generator is running, and/or other status information.
<b>Inverter Status</b>	Provides the status of the inverter.
<b>Engine Coolant Temperature</b>	Displays the temperature of the engine coolant fluid.
<b>Engine Oil Pressure</b>	Displays the pressure of the engine oil, which is required to lubricate the internal engine parts.

## Leveling

Leveling allows you to control the air suspension for ride control when traveling, and for leveling when stationary.

In Auto mode, the vehicle can be automatically leveled while stationary. This mode is the easiest leveling method to use and is suitable for most leveling situations.

Travel mode is operational when the vehicle is in motion. By default, this mode will initiate when the park brake is released, or when the vehicle begins moving. However, it is best for the operator to enter this mode before the vehicle begins moving.

Refer to page 24, Leveling, for more information on using these features.

# SELECTABLE DISPLAY

## Pre-Drive

**Pre-Drive** is an item in the Selectable Display. Use the knob rotation and button press to choose this. Refer to the menu map on page 33.

This is an auto-scrolling list which displays **active** items requiring attention prior to vehicle travel.

After viewing, rotate the knob to select another menu item.



## ACC (if equipped)

Adaptive Cruise Control (ACC) is a cruise control system that adjusts the vehicle speed automatically to maintain a safe distance from vehicles ahead.

This setting allows you to enable or disable ACC. You can also set the (relative) following distance.

Rotate the knob to set following distance, or disable. Press to keep this setting.

The selected distance setting is shown in the speedometer as 1, 2, or 3 filled bars.



Short following distance shown as 1 filled blue bar.

Medium following distance shown as 2 filled blue bars.

Long following distance shown as 3 filled blue bars.

# SELECTABLE DISPLAY

## Brightness

The display **Brightness** is an item in the Selectable Display. Use the knob rotation and button press to choose this. Refer to the menu map on page 33.

Different brightness levels can be set for daytime or nighttime driving. If the headlights are off when the brightness is adjusted, the brightness level will be saved for driving with the headlights off (daytime). If the headlights are on when the brightness is adjusted, that level will be saved for driving with the headlights on (nighttime).

Rotate the knob to adjust the brightness and then press the knob to save for that mode and return to the previous menu.

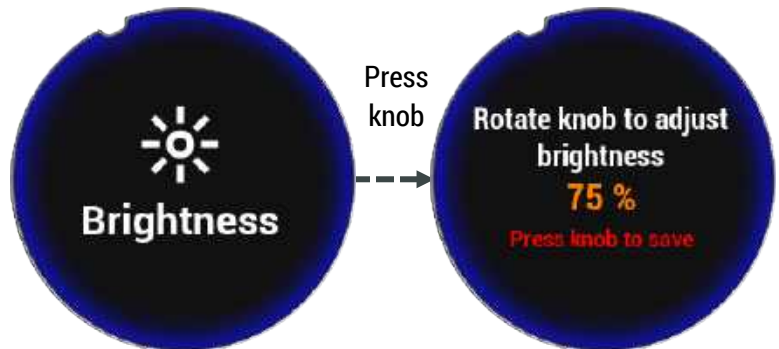

## Settings

The coach must be stopped with the park brake set for this menu item to be available.

**Settings** is an item in the Selectable Display. Use the knob rotation and button press to choose this. Refer to the menu map on page 33.

Rotate the knob to scroll through the available menu items and press the knob to select. To return to the previous menu choose Back.

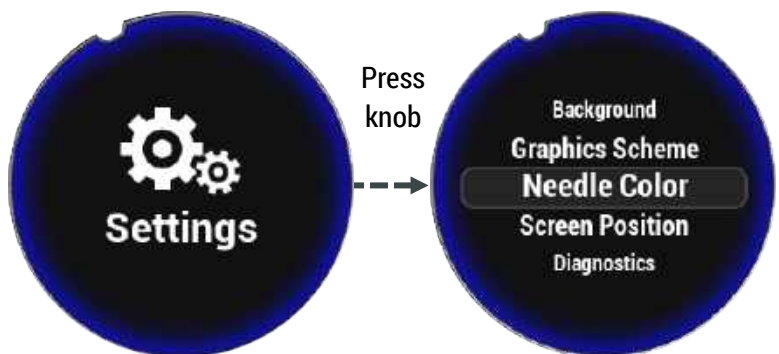

# ADDITIONAL DISPLAYS

## CMS (if equipped)

The Collision Mitigation System (CMS) is a forward-looking, remote-sensing system comprised of collision warning and adaptive cruise control (ACC) with active braking. CMS is displayed in the top half of the speedometer center.

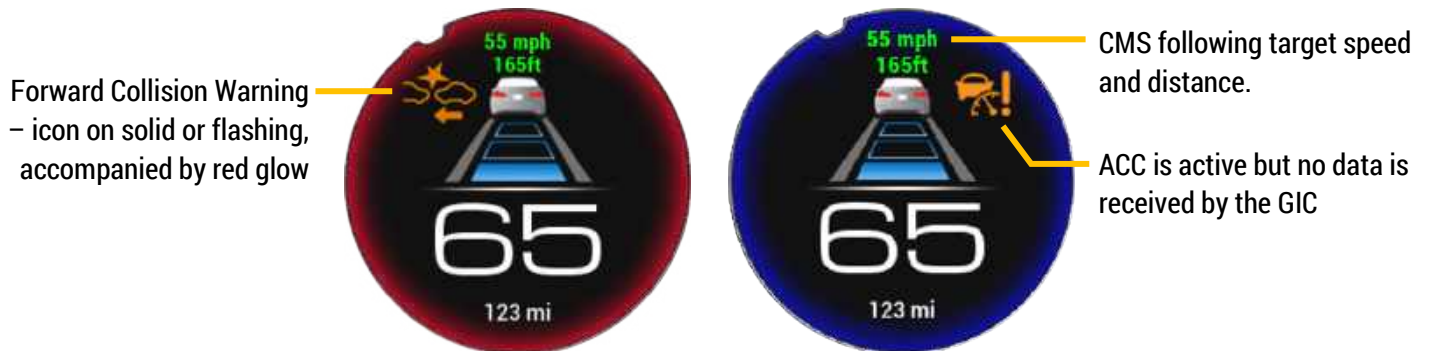

## Mobileye® (if equipped)

Mobileye® is a driver assistance and accident reduction system using an artificial vision sensor to provide information about the road ahead. It is displayed in the top half of the speedometer center.

*For full operating instructions, please refer to your Mobileye® support documentation.*

### Mobileye® Dash Display Elements

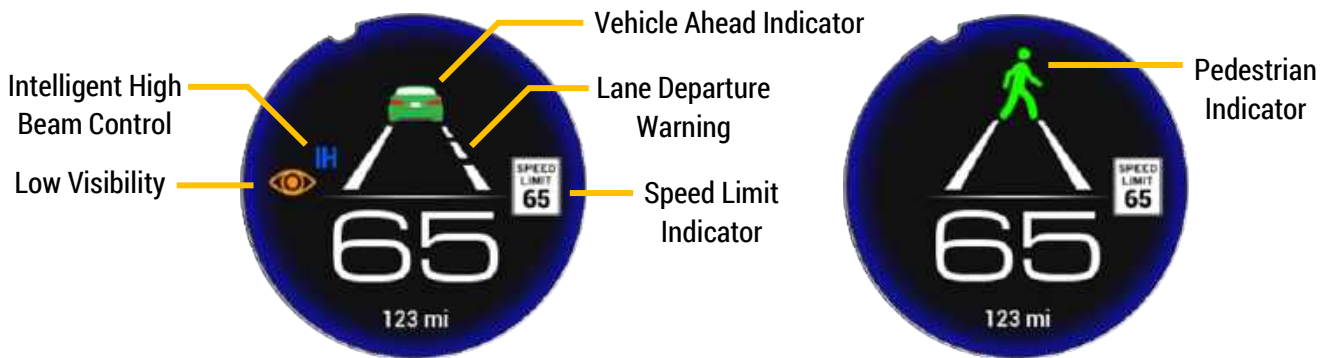

**Note:** If your vehicle is equipped with either CMS or Mobileye®, the speedometer is no longer a selectable center and selections are performed only in the tachometer center display.

# LEVELING

This section describes the leveling operations that can be carried out quickly and easily with the available commands in the Leveling view, if equipped.

## More

---

Go to Leveling > More to access manual leveling commands, as well as additional related operations. This screen is detailed in the following document: VDC00462 – Trueline Leveling System Operation Guide, GIC Interface, Air Only.

## Auto Level Mode

---

Auto mode can be used to automatically level a stationary vehicle using the air suspension. This mode is the easiest leveling method to use and is suitable for most leveling situations.

When Auto is activated, the leveling system detects the lowest corner of the vehicle, and then levels (lowers) the remaining corners to it. If the system determines that it is unable to lower the vehicle to level, any corners that are low will then be raised to the level of the highest corner.

### Using Auto Level Mode

Ensure that:

- The ignition is on and the air system is at full pressure.
- The parking brake is engaged.
- The front wheels are straightened.
  1. Use the knob to go to the Leveling screen. Press to select.
  2. Select **Auto Level** in the menu, and press.



# LEVELING

This initiates a leveling cycle. The leveling status is displayed in the center of the leveling screen.

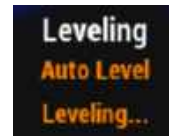

It is possible to stop the leveling process at any time.

1. Activate the leveling menu.
2. Select **Exit Auto** to stop leveling.



## Auto Mode – Notes

Once leveling has been completed, additional leveling cycles can be performed if the system is in auto mode or auto low power mode.

To perform another auto level cycle:

- Select **Exit Auto** to stop leveling. Then choose **Auto Level** again.

If the park brake is released while in auto mode, the Trueline Leveling System switches to travel mode.

**Note:** *The sensitive leveling sensors require that vehicle movement is kept to a minimum during the leveling process. Therefore, if you are inside the vehicle while it is leveling, please sit still or walk lightly.*

## Changing the Height of a Leveled Vehicle

A leveled vehicle can be raised or lowered to adjust the entry doorstep height.

1. To ensure there's an adequate amount of air, the ignition should be on and the air system should be at full pressure.
2. Choose **Raise All** or **Lower All** on the main menu. This causes the vehicle to move up or down while staying level.





# LEVELING

## Travel Mode

Travel mode is the operational mode used when the vehicle is in motion.

This mode controls the vehicle's air suspension system. There are three factory-defined levels:

- High Ride
- Normal Ride
- Low Ride

The leveling system can only be switched to travel mode if the ignition is turned on.

### Using Travel Mode

1. Use the knob to go to the Leveling screen. Press to select.
2. Select **Travel** in the menu, and press. The suspension status will be displayed on the bottom of the screen.
3. The default setting is normal ride height.
  - Select **High Ride** to negotiate uneven terrain.
  - Select **Low Ride** to allow additional clearance to the top of the vehicle.



These heights may be used only under predefined speeds. At higher speeds, the vehicle will go to the normal ride height state, and High Ride and Low Ride will not be available. The maximum speeds at which low and high ride can be maintained are set by the manufacturer.

# ALARM MESSAGES – INFORMATION



**INFORMATION** messages relate to normal activities of the coach.

MESSAGE	DESCRIPTION
Tag Dumped	Tag axle weight has been reduced.

# ALARM MESSAGES – CAUTION



**CAUTION** messages relate to items that require your attention.

MESSAGE	DESCRIPTION
No Cluster Data	The Graphical Instrument Cluster has an internal error – the graphics application has reported it has not received data from the cluster task within the last 15 seconds.
No J1939-I Data	No messages have been received on the J1939 network within the last 15 seconds. Check to confirm the J1939 connector is plugged into the Graphical Instrument Cluster or if there is a problem with the J1939 network.
No Serial-I Data	The Graphical Instrument Cluster has an internal error – the I/O board has not received a valid serial message from the cluster task within the last 15 seconds.
No J1939-C Data	Not receiving any J1939 messages from the Engine Controller.
No Serial-C Data	The Graphical Instrument Cluster has an internal error – the cluster task has not received a valid serial message from the I/O board within the last 15 seconds.
Low Tire Pressure	The Tire Pressure Monitoring System (TPMS) has indicated there is a tire with low pressure. This same message is displayed for both <b>Warning</b> and <b>Critical</b> low pressures. Rotate the joystick knob to view coach and trailer tire pressure screens on the Selectable Display. Press the knob to switch between tire pressure and tire temperature.
High Tire Pressure	The Tire Pressure Monitoring System (TPMS) has indicated there is a tire with a <b>Critical</b> high pressure. Unlike low pressure, a ‘Warning’ alarm does not exist for high pressure. Rotate the joystick knob to view coach and trailer tire pressure screens on the Selectable Display. Press the knob to switch between tire pressure and tire temperature. Refer to pages 18 and 36.
High Tire Temp.	The Tire Pressure Monitoring System (TPMS) has indicated there is a tire with high temperature. Rotate the joystick knob to view coach and trailer tire pressure screens on the Selectable Display. Press the knob to switch between tire pressure and tire temperature.
Low Fuel	The vehicle fuel tank is low – refer to the ‘Distance to empty’ display.
Regen in Process	Indicates that Active Regeneration is in progress (see below).
High Exhaust Temp.	Indicates that high exhaust temperatures may exist due to Active Regeneration (soot burn-off) in the diesel particulate filter (DPF). This is normal and does not signify the need for vehicle or engine service. Ensure the exhaust pipe outlet is not directed at any combustible surface or material.

# ALARM MESSAGES – CAUTION

MESSAGE	DESCRIPTION
ABS Warning	The Anti-Lock Brake System (ABS) has detected a fault and has disabled this feature.
Check Engine	J1939 message received. The engine needs service at the first available opportunity.
MIL Check Engine	J1939 message received. There is a general fault (not necessarily with the engine) that must be diagnosed.
DPF Filter Warning	The exhaust Diesel Particulate Filter (DPF) has excessive soot levels and requires passive or active regeneration (regen) to burn off the soot to prevent a clogged filter. Initiate a parked manual regen or seek service at the first available opportunity.
Low DEF	The diesel exhaust fluid (DEF) is low. The fluid creates a catalytic reaction that removes particles from the exhaust. When low, the fluid must be topped up.
Front Press. Fault	The pressure reading for the front air tank is out of range. This may be caused by a bad pressure transducer or faulty wiring.
Rear Press. Fault	The pressure reading for the rear air tank is out of range. This may be caused by a bad pressure transducer or faulty wiring.
Pre-Drive Items	Refer to the Pre-Drive list shown in the Selectable Display for active pre-drive item(s) which require attention prior to vehicle travel. Refer to the menu map on page 33. The Pre-Drive list on the Selectable Display will automatically scroll up and down as necessary to display all currently active items: <ul style="list-style-type: none"> <li>Antenna Up                      • FD Slide Not Secure</li> <li>Shore Power Connected      • RD Slide Not Secure</li> <li>Entry Step Out                • RP Slide Not Secure</li> <li>Fridge Unlocked               • FP Slide Not Secure</li> <li>Baggage Door Open          • Engine Preheat On</li> <li>Slide Overridden             • Generator On</li> <li>Not at Ride Height            • Emergency Start On</li> </ul>
No RVC Data	The GIC communicates with both RV-C and J1939 communication networks on the coach. The GIC I/O board has not received any RV-C message within the last 15 seconds.
Trans. Over Temp.	Signal from transmission indicating that its fluid temperature is above normal acceptable limits, and as a result, transmission operation may be altered or restricted.
High Coolant Temp.	The coolant fluid temperature is high.
Low Eng. Oil Press.	The engine oil pressure is low.

## ALARM MESSAGES – CAUTION

MESSAGE	DESCRIPTION
ATC Warning	The electronic brake controller (EBC) has detected a fault with the automatic traction control (ATC) and has disabled this feature.
Water in Fuel	Signal which indicates the presence of water in the fuel.
Battery Over Volt	The engine control module (ECM) battery measurement is above the factory-configured high battery threshold.
Battery Under Volt	The engine control module (ECM) battery measurement is below the factory-configured low battery threshold.
Check Trans.	Signal from transmission indicating that some aspect of its operation is not functioning correctly, and as a result, transmission operation may be altered or restricted.
No CCVS Data	The GIC application has not received any cruise control vehicle speed (CCVS) data over the J1939 network within the last 15 seconds.
Comm. Error - Engine	There has been a loss of communication between the GIC and the engine.
Comm. Error - ABS	There has been a loss of communication between the GIC and the anti-lock brake system.
Comm. Error - Trans	There has been a loss of communication between the GIC and the transmission.
ESC Warning	This parameter is controlled by the Vehicle Dynamic Stability Control System. The warning is accompanied by an illuminated ATC indicator.

# ALARM MESSAGES – CRITICAL



**CRITICAL** messages relate to items that require your immediate attention.

MESSAGE	DESCRIPTION
EBS Error	The Electronic Braking System (EBS) has reported a critical error. The EBS controls normal braking in addition to the Anti-Lock Braking System (ABS) and Automatic Traction Control (ATC).
Stop Engine	J1939 message received. The vehicle needs to be stopped as soon as it is safe to do so. An alert tone will sound continuously.
DPF Filter Error	The exhaust diesel particulate filter (DPF) has a critical soot level. Stop engine as soon as possible. Seek service at the first available opportunity.
Extreme Low DEF	The diesel exhaust fluid (DEF) is low. Engine power loss will occur. This will be restored after refilling the DEF tank.
Low Air	The front tank pressure is below the 'red' threshold level. The warning buzzer does not sound when the transmission gear is in neutral.
Low Air	The rear tank pressure is below the 'red' threshold level. The warning buzzer does not sound when the transmission gear is in neutral.
Tire Overspeed	Tires are rated for maximum speeds. If the vehicle goes faster than this speed, this alarm will display.
Trans. Over Temp!	Signal from transmission indicating that its fluid temperature is above normal acceptable limits, and as a result, transmission operation may be altered or restricted.
Check Trans!	Signal from transmission indicating that some aspect of its operation is not functioning correctly, and as a result, transmission operation may be altered or restricted.
Rolling Alarm	If the vehicle is in neutral gear and the brake pedal is not depressed, nor the park brake engaged, this alarm will display.
*Shore Power Connected	This indicates that the vehicle is still connected to shore power with the park brake released.
Shore Power Unknown	This message displays when the generator is running.

\*These messages are accompanied by a red blinking bezel border if the park brake is not set and the vehicle speed is less than 5mph.

# MENU MAP – SELECTABLE DISPLAY MENU

## Selectable Display Menu

This menu configuration applies to vehicles that are equipped with either CMS or Mobileye®

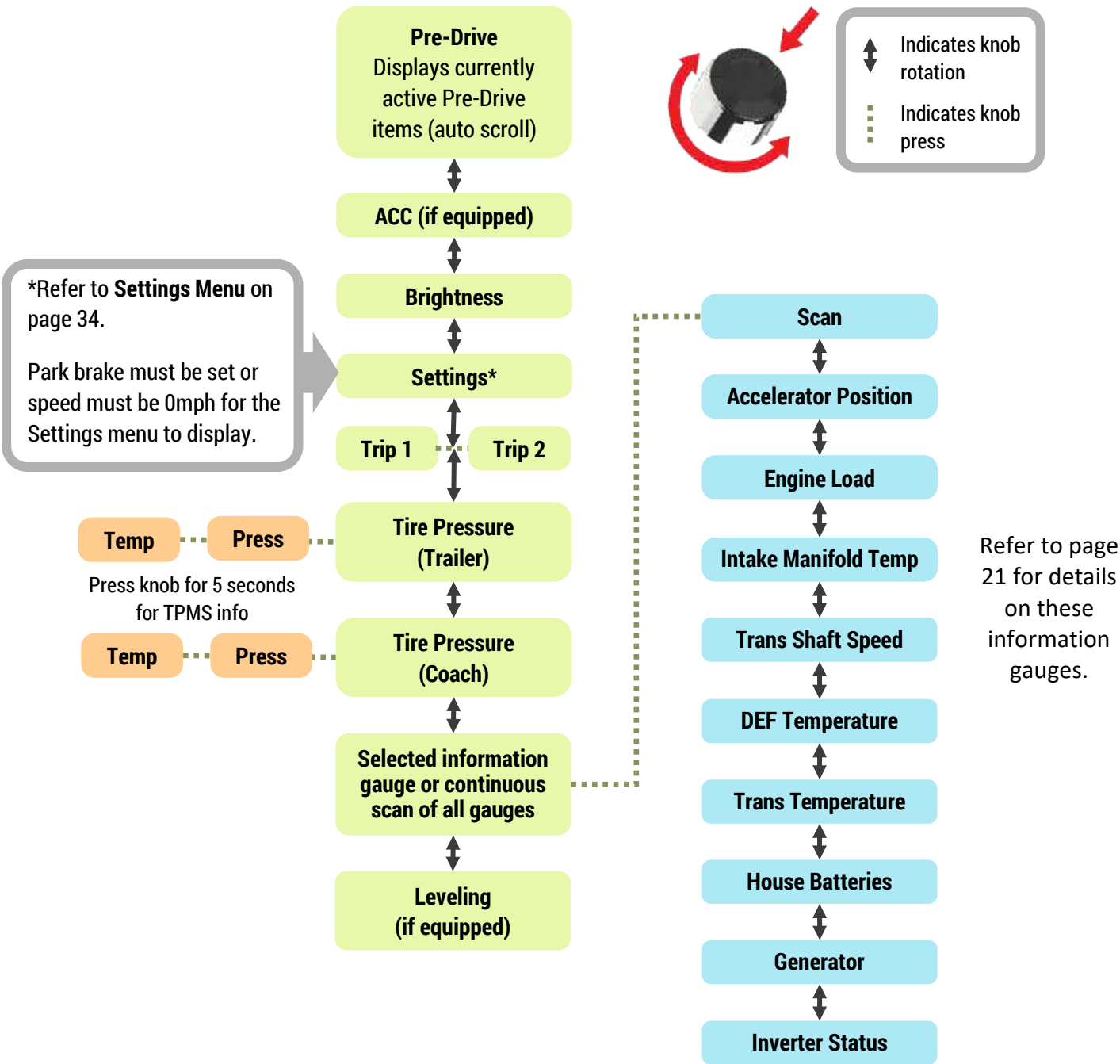

# MENU MAP – SELECTABLE DISPLAY MENU

## Selectable Display Menu

This menu configuration applies to vehicles that are not equipped with either CMS or Mobileye®

To toggle between the speedometer and tachometer menus, push the knob to the right or left.

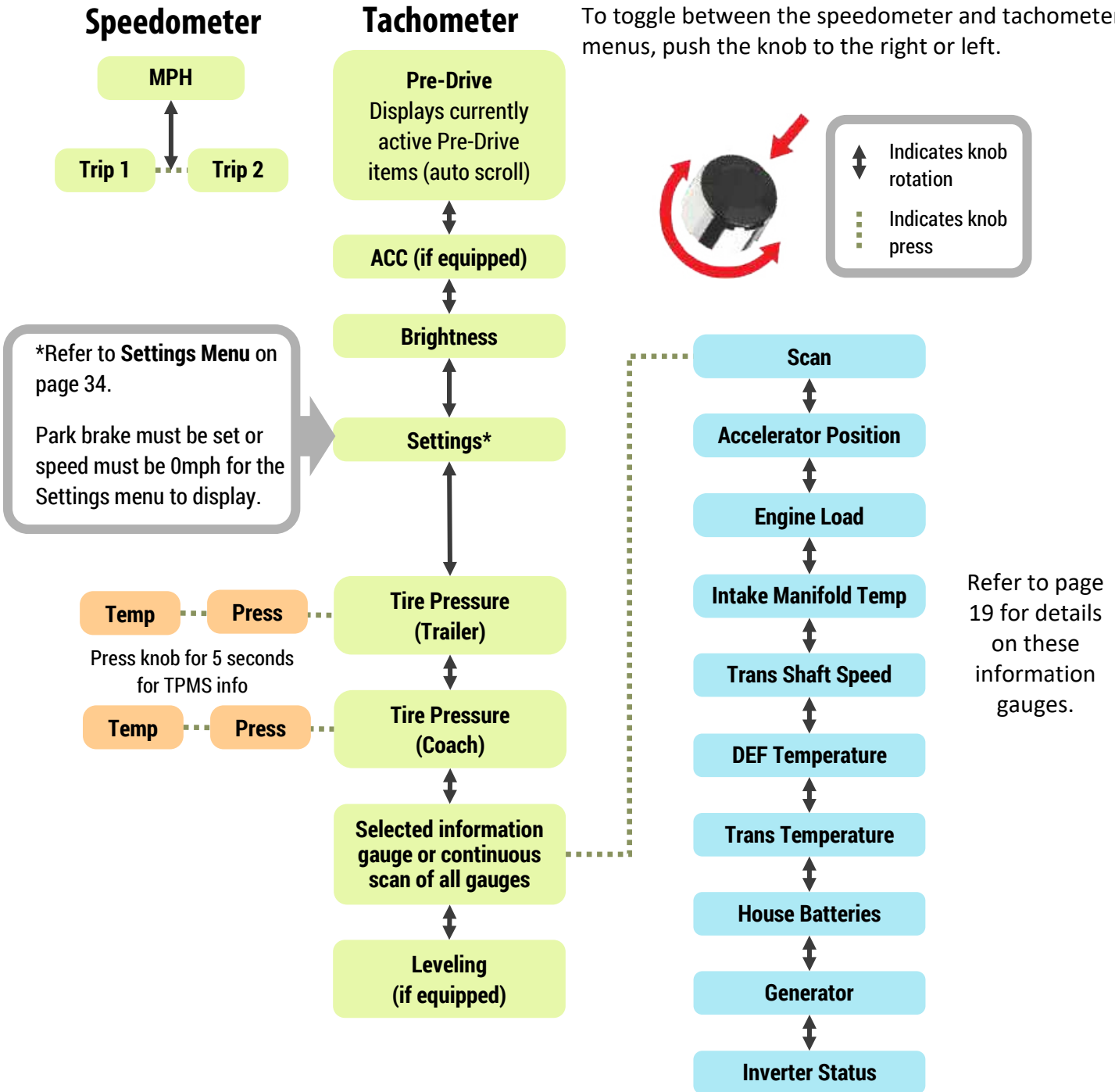



# MENU MAP – SETTINGS MENU

## Settings Menu



# MENU MAP – TIRE PRESSURE (TPMS) SETUP MENU

## TPMS Setup Menu

No ... Yes ... Towable Connected

2 wheels ... 4 wheels ... 6 wheels ... Vehicle ... Tow Type



Indicates knob rotation  
Indicates knob press

Refer to next page for details on the sensor display screen...

Location	ID	Pressure	Temperature	Battery	Ref. Press.	RF Strength	Status
Front Left	0x2EE9	117 psi	70 °F	Ok	116 psi	90	Ok
Front Right	0x5DD2	119 psi	71 °F	Ok	116 psi	90	Ok
RL Outside	0x8CBB	120 psi	71 °F	Ok	116 psi	90	Ok
RL Inside	0XBBA4	122 psi	71 °F	Ok	116 psi	90	Ok
RR Inside	0XEABD	123 psi	72 °F	Ok	116 psi	90	Ok
RR Outside	0x11976	125 psi	72 °F	Ok	116 psi	90	Ok
Tag Left	0x1485F	126 psi	72 °F	Ok	116 psi	90	Ok
Tag Right	0x17748	128 psi	73 °F	Ok	116 psi	90	Ok
Tow FL	0XD9A	34 psi	77 °F	Ok	34 psi	90	Ok
Tow FR	0xDCC	35 psi	77 °F	Ok	34 psi	90	Ok
Tow RL	0xDFE	35 psi	77 °F	Ok	34 psi	90	Ok
Tow RR	0xE30	36 psi	77 °F	Ok	34 psi	90	Ok

- Select Tire
- Front Left
- Front Right
- RL Outside
- RL Inside
- RR Inside
- RR Outside
- Tag Left
- Tag Right

TPMS Configuration  
Exit

Add Sensor ... Cancel Add Sensor

Delete Sensor  
Update Reference Pressure  
Back

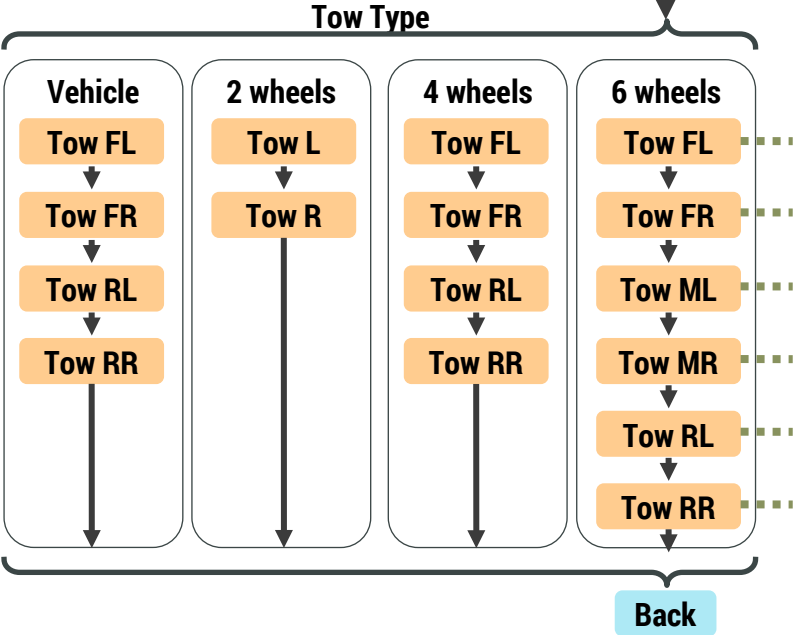

1. Inflate the tire to the manufacturer's recommended pressure.
2. Select 'Add Sensor' and then physically screw the pressure sensor onto the tire valve stem. The GIC will automatically detect the new sensor and update its 'ID' to the selected tire.
3. Select 'Update Reference Pressure' and wait for up to 1 minute for the 'Ref. Press.' value to display; wait for up to 5 minutes for the pressure sensor to transmit its next reading for the 'Pressure' to display an accurate value.

# TIRE PRESSURE (TPMS) SENSOR DISPLAY

Location	ID	Pressure	Temperature	Battery	Ref. Press.	RF Strength	Status
Front Left	0x2EE9	117 psi	70 °F	Ok	116 psi	90	Ok
Front Right	0x5DD2	119 psi	71 °F	Ok	116 psi	90	Ok
RL Outside	0x8CBB	120 psi	71 °F	Ok	116 psi	90	Ok
RL Inside	0XBBA4	122 psi	71 °F	Ok	116 psi	90	Ok
RR Inside	0XE8D	123 psi	72 °F	Ok	116 psi	90	Ok
RR Outside	0x11976	125 psi	72 °F	Ok	116 psi	90	Ok
Tag Left	0x1485F	126 psi	72 °F	Ok	116 psi	90	Ok
Tag Right	0x17748	128 psi	73 °F	Ok	116 psi	90	Ok
Tow FL	0XD9A	34 psi	77 °F	Ok	34 psi	90	Ok
Tow FR	0xDCC	35 psi	77 °F	Ok	34 psi	90	Ok
Tow RL	0xDFE	35 psi	77 °F	Ok	34 psi	90	Ok
Tow RR	0xE30	36 psi	77 °F	Ok	34 psi	90	Ok
---	---	---	---	---	---	---	---
---	---	---	---	---	---	---	---

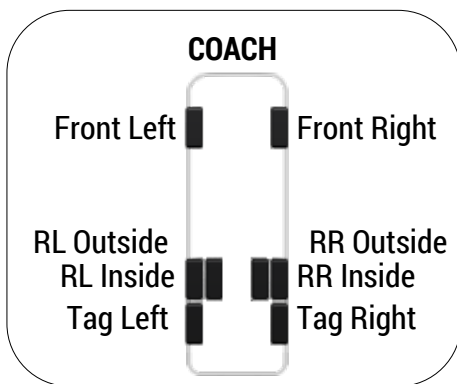

The 'reference pressure' (**Ref. Press.**) is established from the current tire pressure.

In early versions of the Pressure-Pro system, the 'reference pressure' was set as soon as the tire sensor was screwed onto the valve stem. However, in later versions, it is necessary to use the '**Update Reference Pressure**' menu selection; refer to page 39.

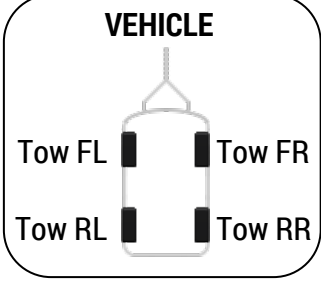
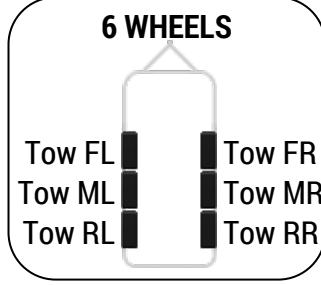
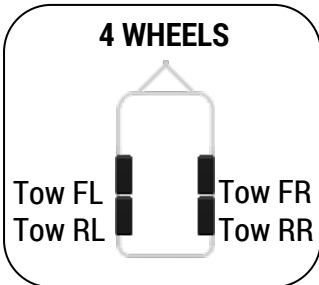
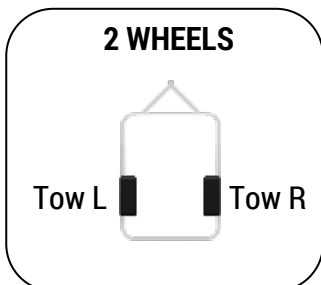

If tire pressure sensors are moved between towable vehicles with a different number of wheels, it is suggested that only the **common front wheel sensors** are moved. This allows them to be moved without having to delete and add sensors. However, it may still be necessary to '**Update Reference Pressure,**' depending on the manufacturers recommend pressures.

# TIRE PRESSURE (TPMS) CONFIGURATION

The Tire Pressure Monitoring System (TPMS) consists of multiple sensors which screw onto tire valve stems and communicate to a central module. This module puts the data onto the J1939 network, where it is read by the GIC. The low tire pressure threshold is factory programmed within the TPMS central module. There is an ID printed on each tire pressure sensor, for example OB5A53. Each ID is displayed once it has been added in the TPMS configuration screen.

The TPMS configuration displays 14 tire locations. The last six (6) are for the towable vehicle, where any unused tire locations are shown in a light gray color. This allows all configured tire sensors to be displayed, regardless of the tow vehicle type. This is particularly useful if a tire needs to be moved from a currently unused location to another tire location, because it cannot be added until it is first removed from the original location.

## Towable Connected

Refer to the TPMS setup menus on page 35.

Press the button knob to toggle between 'Yes' and 'No'

Parameter	Default	Configuration choices
Towable Connected	No	Yes or No

## Tow Type

Refer to the TPMS setup menus on page 35.

Press the button knob repeatedly to select the number of wheels.

Parameter	Default	Configuration choices
Tow Type	2 wheels	2 wheels, 4 wheels, 6 wheels or vehicle

## Add Sensor

Select 'Add Sensor' just prior to screwing a sensor onto a tire valve stem.

**Note 1:** If an existing sensor is to be moved to another tire, it must first be removed from the original tire using 'Delete Sensor'. Refer to page 38.

**Note 2:** It is not necessary to use 'Add Sensor' if a sensor is removed to manually inflate the tire, provided the same sensor is replaced.

Refer to the TPMS setup menus on page 35 (*password may be required*). Rotate the knob to highlight a menu item and then press the knob to make a selection.

To add a tire pressure sensor:

1. The 'Towable Connected' parameter must be set to **Yes**.
2. The 'Tow Type' parameter must be chosen for the relevant number of wheels.
3. If required, enter the password.

# TIRE PRESSURE (TPMS) CONFIGURATION

Note: This is an independent password entry screen compared to that used for the other configurations.

4. Rotate the knob to select a tire.
5. Choose 'Add Sensor.'
6. Screw the tire pressure monitor onto the valve stem and wait until its ID is detected.

(If required, press the knob to 'Cancel Add Sensor')

7. Select 'Back' and repeat from step 4 to add additional tire sensors.
8. Refer to page 39 for instructions on updating the reference pressure for each sensor added.



## Delete Sensor

'Delete Sensor' will remove a sensor from the selected tire location. This is required if a sensor is to be relocated to a different tire.

Refer to the TPMS setup menus on page 35 (*OEM or service password may be required*).

Rotate the knob to highlight a menu item and then press the knob to make a selection.

To delete a tire pressure sensor:

1. The 'Towable Connected' parameter must be set to **Yes**.
2. The 'Tow Type' parameter must be chosen for the relevant number of wheels.
3. If required, enter the password.

Note: This is an independent password entry screen compared to that used for the other configurations.

4. Rotate the knob to select a tire.
5. Choose 'Delete Sensor'.
6. Repeat from step 4 to delete additional tire sensors.

# TIRE PRESSURE (TPMS) CONFIGURATION

## Update Reference Pressure

**Prerequisites:** This procedure requires the tire to be inflated to the manufacturer's recommended pressure because the reference pressure is established from the current tire pressure. It may also be necessary to wait for up to 5 minutes for a pressure sensor to transmit its current tire pressure.

Refer to the TPMS setup menus on page 35 (password may be required).

Rotate the knob to highlight a menu item and then press the knob to make a selection.

To update the reference pressure for a tire pressure sensor:

1. The 'Towable Connected' parameter must be set to **Yes**.
2. The 'Tow Type' parameter must be chosen for the relevant number of wheels.
3. If required, enter the password.

Note: This is an independent password entry screen compared to that used for the other configurations.

4. Rotate the knob to select a tire.
5. Choose 'Update Reference Pressure'.

Note: Wait for up to 1 minute for the '**Ref. Press.**' value to display and then wait for up to 5 minutes for the pressure sensor to transmit its next reading for the '**Pressure**' to display an accurate value.

6. Repeat from Step 4 to update the reference pressure for additional tire sensors.

# DIAGNOSTICS

The diagnostic screens are found in the System menu. They provide information that is helpful for service staff when troubleshooting any issues, and are discussed in greater detail in the Service Manual.

Screen	Description
I/O Info	Shows the status of the discrete inputs and outputs connected directly to the rear connectors on the GIC.
System Info	Displays the status of any alert message received since the ignition was turned on. The part numbers, firmware revisions and serial number are also shown.
OBD Info	Displays the status of any diagnostic message (DM1) received since the ignition was turned on.
J1939 CAN Info	Displays all devices communicating on the vehicle's J1939 Controller Area Network (CAN).
RVC CAN Info	Displays all devices communicating on the vehicle's RVC Controller Area Network (CAN).



5320 48 Ave. SE • Salmon Arm, BC, Canada V1E 1X2

Phone: 250-832-6477 • 24-hour Emergency Technical Support: 250-804-1247

Fax: 250-832-7746 • [sales@validmanufacturing.com](mailto:sales@validmanufacturing.com)

[www.validmanufacturing.com](http://www.validmanufacturing.com)



# Leveling

---



# **TRUeline LEVELING SYSTEM**

---

## **OPERATION GUIDE, GIC LEVELING INTERFACE**

VDC00462

**TIFFIN, AIR ONLY**

Rev - 21 April 2020 MW

Copyright © 2020 Valid Manufacturing Ltd. All rights reserved.

Information in this document is subject to change without notice. No part of this document may be reproduced or transmitted, in whole or in part, in any form, or by any means, electronic or mechanical, for any purpose, without the express written permission of Valid Manufacturing Ltd.

# CONTENTS

Safety Instructions .....	4	Manual Override .....	12
Warning.....	4	Travel.....	14
Caution.....	4	Travel Mode (Ride Height).....	14
Overview .....	5	Using Travel Mode .....	14
Selecting Menu Items .....	5	Travel Mode – Notes.....	15
Operation .....	6	Low Ride Height Warning .....	15
Auto Level Mode.....	6	Tag Dump (if equipped) .....	15
Manual Level Mode .....	6	Using Tag Dump .....	15
Travel Mode .....	6	Tag Axle Air Bag Control .....	16
Level Indicator.....	7	System Commands.....	17
Output Display .....	7	Info .....	17
Leveling .....	8	Diagnostics .....	17
Auto Level Mode.....	8	Clearing Diagnostic Messages.....	18
Using Auto Level .....	8	Low Battery .....	18
Auto Leveling Cycle.....	9	Level Zero .....	19
Once the Vehicle Has Been Leveled.....	9	Travel Zero .....	19
Auto Mode – Notes.....	10	RH (Ride Height) Setup .....	19
Changing the Height of a Leveled Vehicle .....	10	Tag Setup (if equipped).....	19
If the Vehicle Cannot be Leveled .....	10	Config .....	19
Manual Level Mode .....	11	Status Messages.....	20
Using Manual Level Mode .....	11	Twist .....	20
All Raise, All Lower .....	11	Park .....	20
All Raise – Lock On .....	11	Slope.....	20
Manual Mode – Notes .....	12		

# SAFETY INSTRUCTIONS

## Warning

---

- Do not use the vehicle's suspension to support the vehicle for servicing or inspection. Instead, install adequate blocking before working under any vehicle. The system is designed as a 'leveling' system only.
- Keep people clear of coach while leveling system is in use.

## Caution

---

- Read and understand all operators' manuals before using or servicing your leveling system.
- Ensure that the area around the vehicle is clear of obstructions before operating the leveling system.
- Your leveling system should be serviced only by qualified personnel.
- Leaks in a vehicle's air system can cause the vehicle to lower over time regardless of whether or not the leveling system is operational.

# OVERVIEW

The leveling and electronic ride height system uses electronics to control the air suspension for ride control when traveling, and to control the air suspension for leveling when stationary.

The stationary leveling features have both an automatic and manual mode. Auto mode levels the coach using the air suspension with a single command. Manual mode allows each corner to be individually raised and lowered to manually level the coach. Manual mode can be used with confidence, as the system does not allow the coach chassis to be twisted beyond allowable limits.

When traveling, the ride height of the vehicle can be adjusted. Normal ride height is automatically selected by default. However, the ride height of the coach can be raised or lowered as needed. For example, high-ride may be selected to negotiate uneven terrain; likewise, low-ride may be selected to give additional clearance to the top of the vehicle.

This document explains the features of the suspension control system, and is intended to be used in conjunction with the Graphical Instrument Cluster (GIC) operation guide.

For instructions on using other features of the GIC, please refer to the GIC operation guide.

## Selecting Menu Items

---

When using the rotary knob:

- Rotate the knob to highlight an item.
- Press the knob to confirm your selection.

# OPERATION

The Trueline Leveling System is controlled with the graphical instrument cluster (GIC) interface. There are three main leveling operating modes – auto level mode, manual level mode, and travel mode.

The Trueline Leveling System is on when the ignition is on. The leveling mode and status are displayed on the GIC.

This manual describes all functions available on the leveling popup screen (accessed by selecting **More** on the main GIC display).

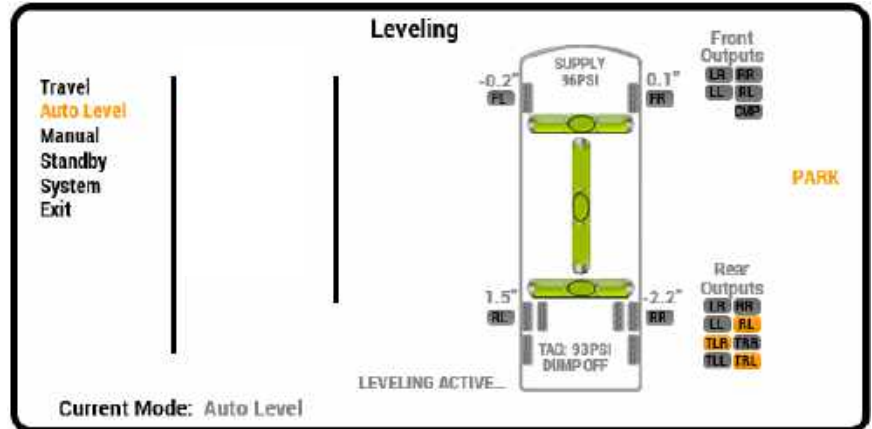

Please refer to the GIC operation manual for information on using the other leveling functions available on the main GIC display.

## Auto Level Mode

Auto mode can be used to level the vehicle automatically when the vehicle is stationary. This mode is the easiest leveling method to use and is suitable for most leveling situations.

## Manual Level Mode

Manual mode allows the operator to raise or lower each corner of the vehicle individually with the air suspension. Up to two corners can be operated at the same time, or all corners can be raised or lowered at once.

Manual mode can be used when the ignition is on or off, and when the vehicle is traveling at low speeds (up to 5 mph).

## Travel Mode

Travel mode is operational when the vehicle is in motion. By default, this mode will initiate when the park brake is released, or when the vehicle begins moving. However, it is best for the operator to enter this mode before the vehicle begins moving to allow time for the vehicle to achieve ride height.

Because the Trueline Leveling System collects information on the ground speed of the vehicle, the operational mode may change automatically depending on the state of the vehicle. For instance, in manual mode, the coach can be driven up to a speed of 5 mph, but if the speed increases, the system will switch to travel mode.

# OPERATION

## Level Indicator

In auto and manual mode, the three level indicator displays can be viewed as a builder's level. The bubbles move to the center once that axis is level.

*In this example, the front axle is high on the left side, the front of the vehicle is high, and the rear axle is level.*

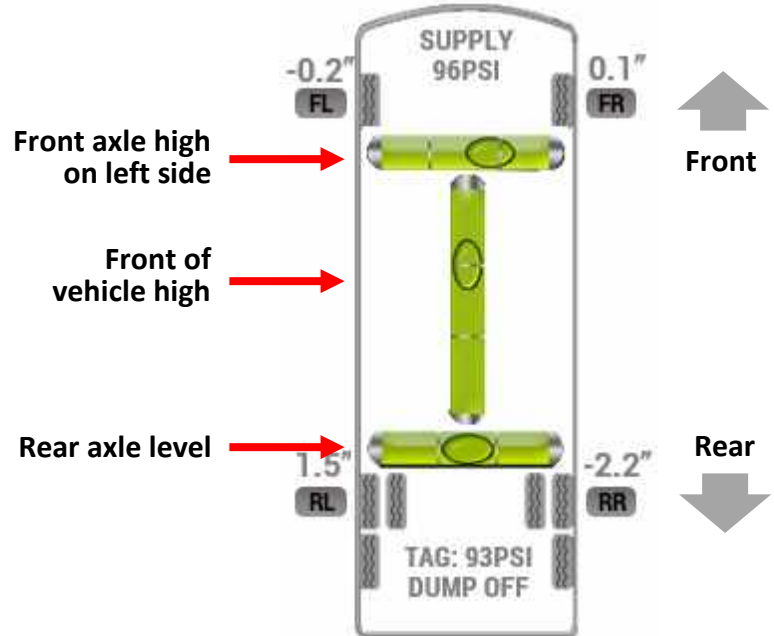

## Output Display

The outputs display on the right indicates which valves are active during any leveling operations. Active valves are shown in orange.

*In this example, the front raise valve is active. This is indicated both on the coach display and in the outputs display at the right.*

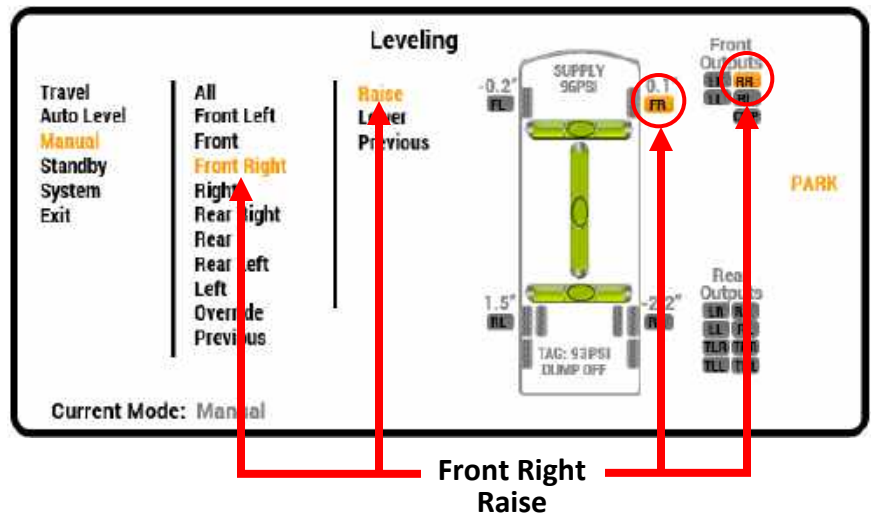



# LEVELING

## Auto Level Mode

Auto level mode automatically levels the vehicle using the air suspension.

When Auto mode is activated, the leveling system detects the lowest corner of the vehicle, and then levels (lowers) the remaining corners to it. If the system determines that it is unable to lower the vehicle to level, any corners that are low will then be raised to the level of the highest corner.

## Using Auto Level

1. Ensure that:
  - The ignition is on and the air system is at full pressure.
  - The park brake is engaged.
  - The front wheels are straightened.
2. Select **Auto Level**. This initiates a leveling cycle. The leveling status is displayed on the bottom of the screen.

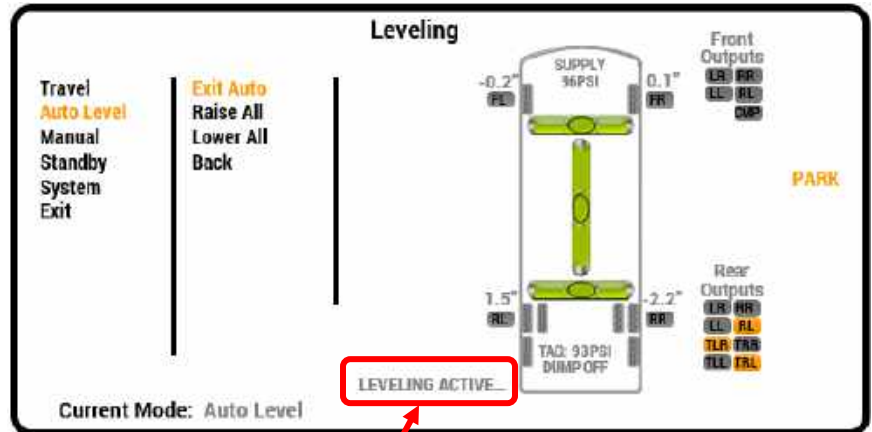

Leveling status

**Note:** The sensitive leveling sensors require that vehicle movement is kept to a minimum during the leveling process. Therefore, if you are inside the vehicle while it is leveling, please sit still or walk lightly.

# LEVELING

At any time during the leveling process, it is possible to stop, or go into manual leveling mode.

1. With Auto Level active, navigate to the next menu.
2. Select **Exit Auto** to stop leveling. To exit this menu without stopping the air auto leveling process, select **Back**.

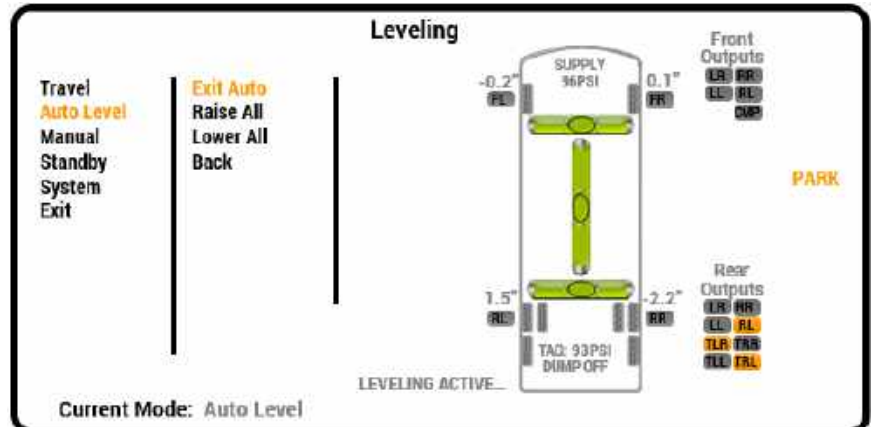

## Auto Leveling Cycle

The leveling mode is indicated at the bottom of the screen.

The Trueline Leveling System begins by finding the lowest corner of the vehicle. It then lowers the other three corners until the vehicle is level. As the vehicle lowers, it monitors the suspension height. If it reaches the minimum height, it will stop lowering the high corners and begin raising the low corners until the vehicle is level.

Once the auto leveling process completes, the vehicle should be level and the system will go into low power mode.

## Once the Vehicle Has Been Leveled

The leveling system stores the electronic ride height of the vehicle, measured using the ride height sensors.

After 20 seconds, the leveling system enters "low power" mode indicated by the Auto Air LP status on the display. Once the ignition is turned off, the leveling system will go to sleep.

After a period of time (2 hours default) in low power mode, the leveling system automatically wakes up and checks to see if re-leveling is required.

- If no leveling is required, the system goes back to sleep.
- If leveling is required, the Trueline Leveling System returns the vehicle to the previously stored leveled height.

# LEVELING

## Auto Mode – Notes

Once leveling has been completed, additional leveling cycles can be performed if the system is in auto mode or auto low power mode.

### To perform another auto level cycle:

- Select **Auto Level** > **Exit Auto** to stop leveling and start another level cycle.
- Select **Back** to stop leveling without starting another level cycle.

If the park brake is released while in auto mode, the Trueline Leveling System will switch to manual mode and then to travel mode, if the vehicle accelerates to a speed above 5 mph.

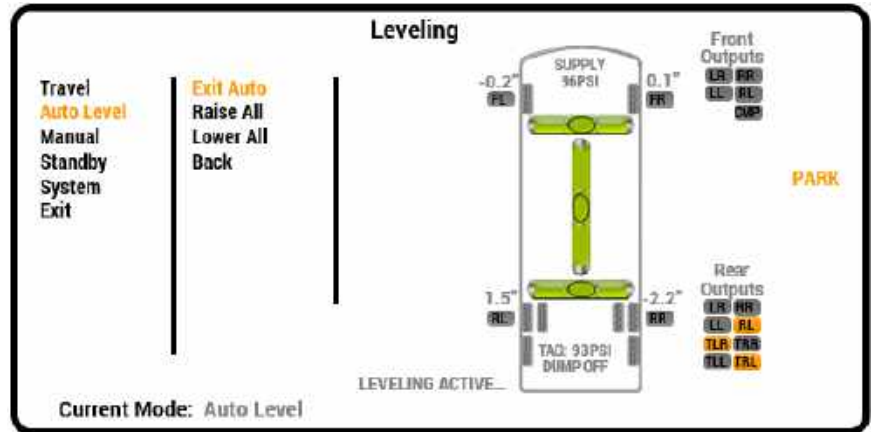

## Changing the Height of a Leveled Vehicle

A leveled vehicle can be raised or lowered to adjust the entry doorstep height.

1. To ensure there's an adequate amount of air, the ignition should be on and the air system should be at full pressure.
2. Select **Auto Level** > **Raise All** or **Lower All**.

This causes the vehicle to move up or down while staying level.

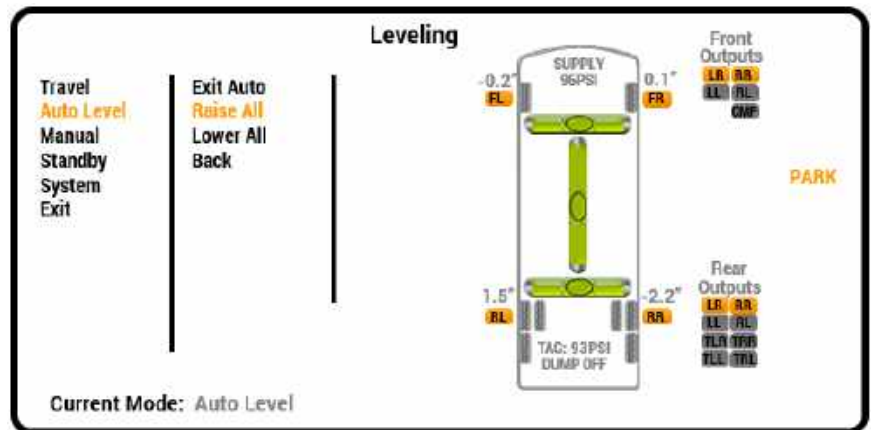

## If the Vehicle Cannot be Leveled

If the leveling system is unable to level the vehicle, the **SLOPE** status is displayed and the system goes into low power mode. If this happens, the system has determined that it would need to exceed the factory set height limits to level the vehicle.

Auto Level can be selected to try leveling again, but if the **SLOPE** status is displayed again, it is not possible to fully level the vehicle on this surface and the vehicle should be moved to a more level surface.

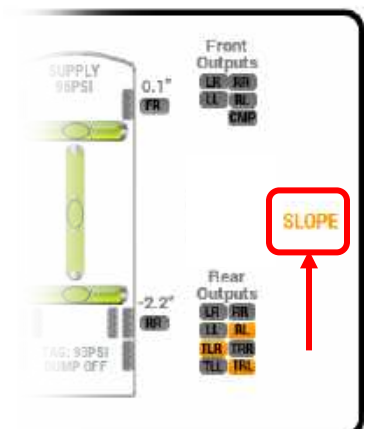

# LEVELING

## Manual Level Mode

Use manual leveling mode to manually adjust each corner of the vehicle. The vehicle can also be lowered or raised by using the All Lower/All Raise command.

### Using Manual Level Mode

Ensure that the vehicle is either parked (but still running) or traveling slower than the manual mode speed limit (5 mph).

If the vehicle is parked, make sure the front wheels are straight.

**Note:** The **Brake** indicator will flash if the park brake is set but the vehicle is still in gear. Once the vehicle has been put in neutral with the park brake on, the **Brake** indicator will stop flashing and remain lit.

1. Select **Manual Level**.
2. Select the corner(s) you wish to adjust.
3. Select **Raise** or **Lower**.
4. To control all four corners simultaneously, use **All > Raise** or **Lower**. This can be useful to adjust the entry step height.
5. To exit the menu, select **Previous**.

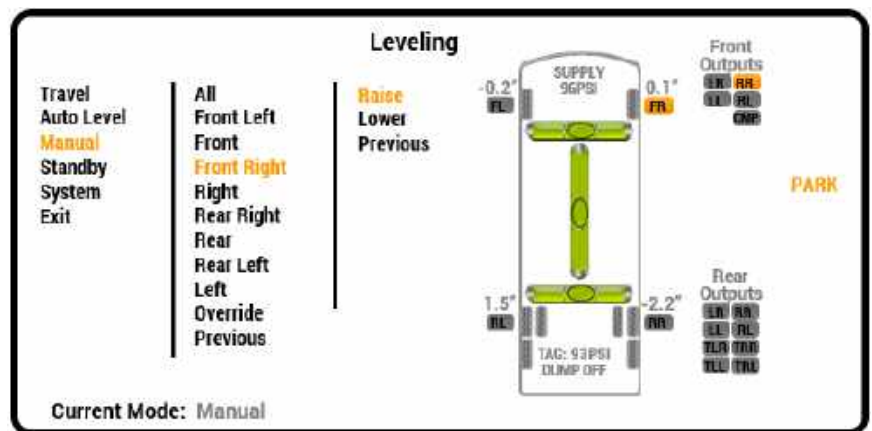

### All Raise, All Lower

In manual mode, the entire vehicle may be raised or lowered while either parked or moving slowly.

To control all four corners simultaneously, use **Manual Air > All > Raise** or **Lower**.

### All Raise – Lock On

To allow greater freedom, All > Raise has a lock feature that keeps the function activated after the rotary knob is pressed for 3 seconds.

In manual mode, navigate to **All > Raise** and press rotary knob for 3 seconds. This 'locks' the function on for a period of one minute.

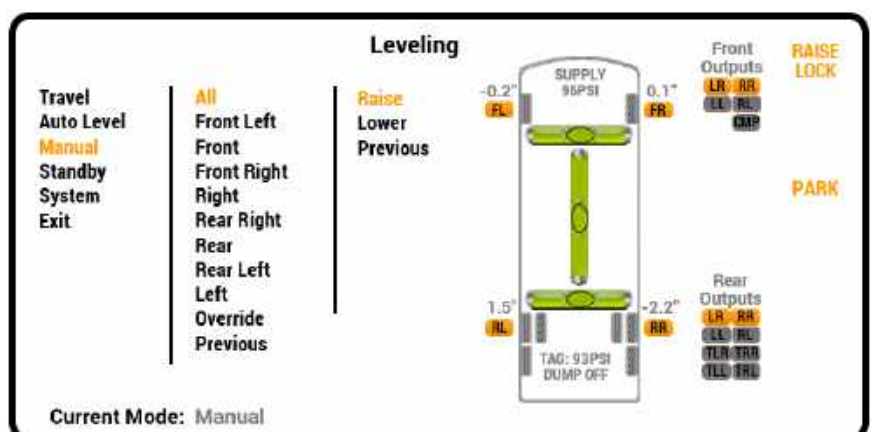

# LEVELING

- During this time, the vehicle raises continuously and the control panel sounds a repeated beeping tone.
- After one minute is over, the vehicle stops raising.
- The process may be repeated until the vehicle is at the desired height.
- To stop the raising process during the one-minute period, briefly select one of the other manual raise or lower functions.

## Manual Mode – Notes

- In manual air mode, if the vehicle begins to move, the Trueline Leveling System automatically switches from manual mode to travel mode at speeds higher than 5 mph.
- If the Trueline Leveling System detects an excess amount of twist in the vehicle frame during the manual adjustments, the **TWIST** status will be displayed. Any further actions that may cause more twist are not permitted by the system.
- Also, if the system detects that the height of a corner is exceeding the factory set height limit (high or low), then the corner will not raise if too high, or lower if too low.

**For example:** If the vehicle is in a state as indicated at right, the leveling system will not allow the right front to be raised, the left front to be lowered, the left rear to be raised, or the right rear to be lowered.

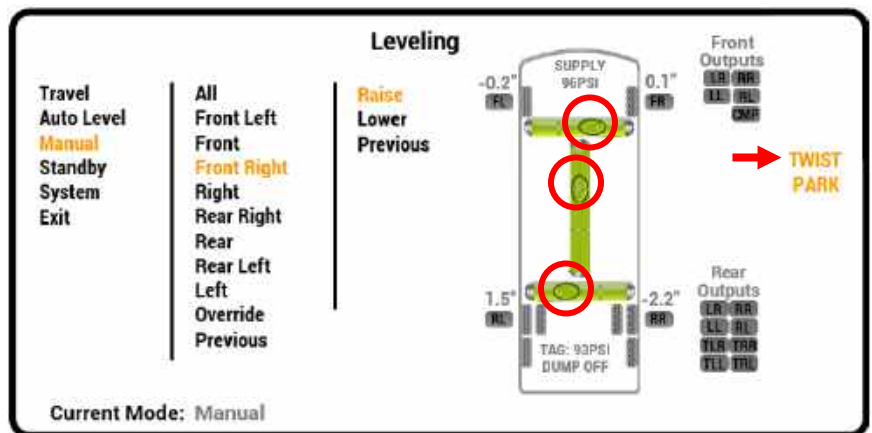

## Manual Override

It is possible to override the twist limits when manually leveling. This should be done only if absolutely necessary, as damage to the chassis could occur.

1. In the Manual menu, select **Override**. A warning will be displayed.
2. If you are certain that you wish to proceed, select **Enable Override Mode**.

**Manual Override**

Manual override mode disables the chassis twist and height limits, allowing full control of the coach air suspension.

Care must be taken to ensure that excessive twist is not introduced in the coach chassis, and that clearances are maintained outside the low and high limits.

**Enable Override Mode** Cancel

# LEVELING

3. Proceed with manual leveling. A status message at the bottom of the display indicates that you are in manual override mode.
4. To exit manual override mode, select **Override**. The TWIST/LIMITS OVERRIDE message will disappear.

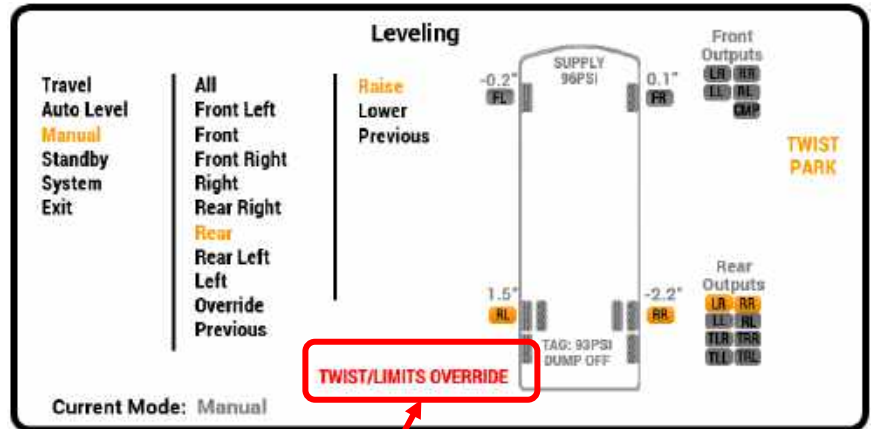

Manual override mode

# TRAVEL

## Travel Mode (Ride Height)

Travel mode is the operational mode used when the vehicle is in motion.

This mode controls the vehicle's air suspension system. There are three factory-defined levels:

- High Ride
- Low Ride
- Standard Ride

The leveling system can only be switched to travel mode if the ignition is turned on. Switching to travel mode causes the suspension to go to ride height.

### Using Travel Mode

1. Turn on the ignition.
2. Select **Travel**. The default setting is Standard ride height.
3. Select the desired travel height.
  - **High Ride** assists in negotiating uneven terrain.
  - **Low Ride** allows additional clearance to the top of the vehicle.
  - **Standard Ride** is the normal ride height.

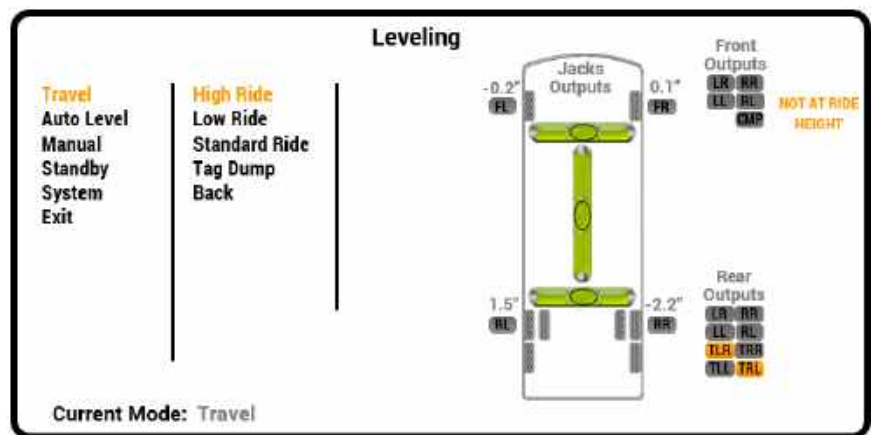

High Ride and Low Ride may be used only under predefined speeds. At higher speeds, the vehicle will go to standard ride height, and High Ride and Low Ride options will not be available. The maximum speeds at which low and high ride can be maintained are set by the manufacturer.

When the Trueline Leveling System is in Standby or Auto mode, it will automatically switch to Travel mode if the park brake is released. When the Trueline Leveling System is in Manual mode, it will stay in Manual mode when the park brake is released, and will switch to Travel mode if the vehicle speed exceeds 5mph.

If the park brake is released before travel ride height is reached, the system will sound a tone every second until the normal height is achieved, or until the park brake is set.

# TRAVEL

**Warning:** The time required to achieve ride height varies with vehicle design. It is the operator's responsibility to ensure that the vehicle is at an adequate height before driving. If the vehicle is too low, severe damage can result to the fenders when the wheels are turned.

## Travel Mode – Notes

- When travel mode is entered from auto or manual mode, a tone will sound until ride height is achieved. It will also sound if high ride, low ride or standard ride mode are set, and will continue until the desired ride height is achieved. It is strongly advised not to move the vehicle while the tone is sounding. It is also inadvisable to negotiate uneven terrain while in low ride.
- Unlike mechanical ride height systems, the automatic ride height system is intelligent, and therefore will not attempt to make ride height corrections while the vehicle is cornering or braking.

## Low Ride Height Warning

A tone (one long beep per second) will sound if:

- The vehicle's ride height is below a predefined limit, and
- The system is in manual or travel mode, and
- The park brake is off.

This indicates that the suspension is below a safe height and fender damage could occur when turning the wheels.

## Tag Dump (if equipped)

Normally, the tag axle dump is controlled automatically by the vehicle situation.

With Manual Tag Dump, the tag air bag pressure can be reduced at low speeds (typically under 20 mph) to transfer the weight from the tag axle to the rear drive axle.

This results in decreased tag axle tire drag while turning, and increased traction in low grip conditions.

## Using Tag Dump

1. In travel mode, select Tag Dump while stationary or at low speeds to deflate the tag axle air bags.
2. If Tag Dump is selected again or the vehicle speed increases above the low speed threshold, the tag axle air bags will inflate.

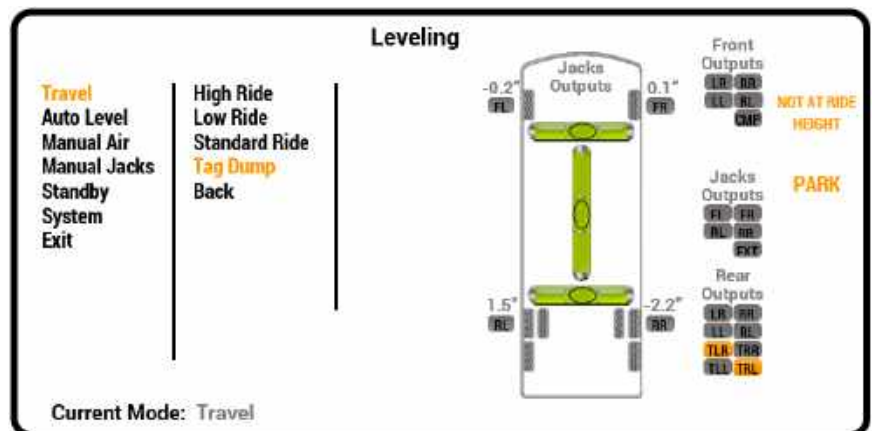



## **Tag Axle Air Bag Control**

In travel mode, the tag axle air bag pressure is monitored with a pressure transducer. The tag raise and lower valves are activated to maintain tag axle air bag pressure.

In auto or manual modes, the tag axle raise and lower valves are operated together with drive axle raise and lower valves.

# SYSTEM COMMANDS

Various system commands can be accessed by navigating to the **System** menu.

## Info

The Info screen displays part numbers for the leveling system components. This screen is used mainly by service personnel under the guidance of Valid's technical support staff.

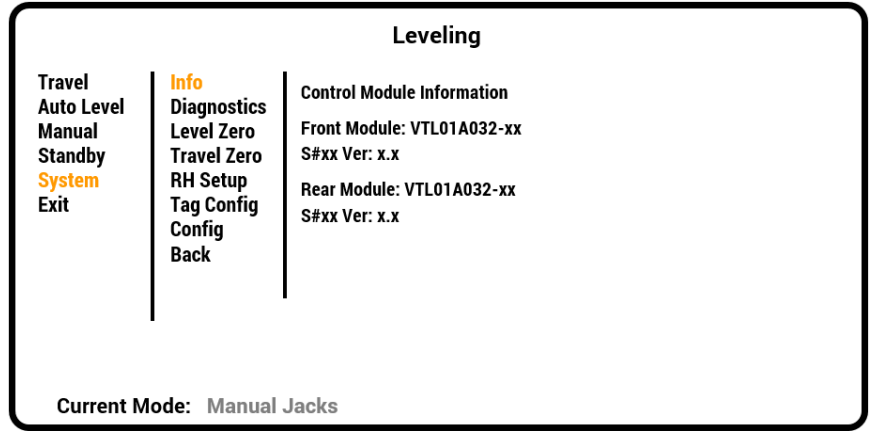

## Diagnostics

The Diagnostics screen displays any current diagnostic messages within the leveling system.

The vehicle operator will be alerted to any diagnostic messages by the presence of this icon on the main (More) screen:



The diagnostic messages are displayed in the order of occurrence.

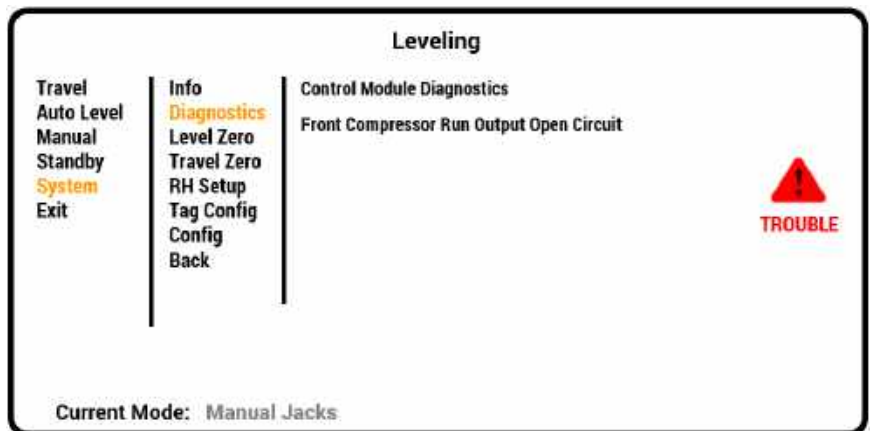

**Warning:** If the **TROUBLE** indicator is on, the suspension may be inoperative. **DO NOT DRIVE** the vehicle and call for assistance.

**Note:** If you contact the service department about a diagnostic message, first write down the information displayed, for all diagnostic messages present. This will help them diagnose the problem if the message list has been cleared in the meantime.

# SYSTEM COMMANDS

## Clearing Diagnostic Messages

To clear any diagnostic messages, navigate to an item in the **Diagnostics** menu.

- Select **Clear** to clear.
- Select **Exit** to exit the dialog without clearing the messages.

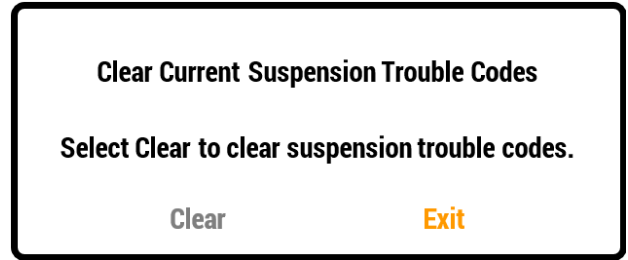

## Low Battery

If the chassis battery voltage is low, the rear module sends a message to the GIC.

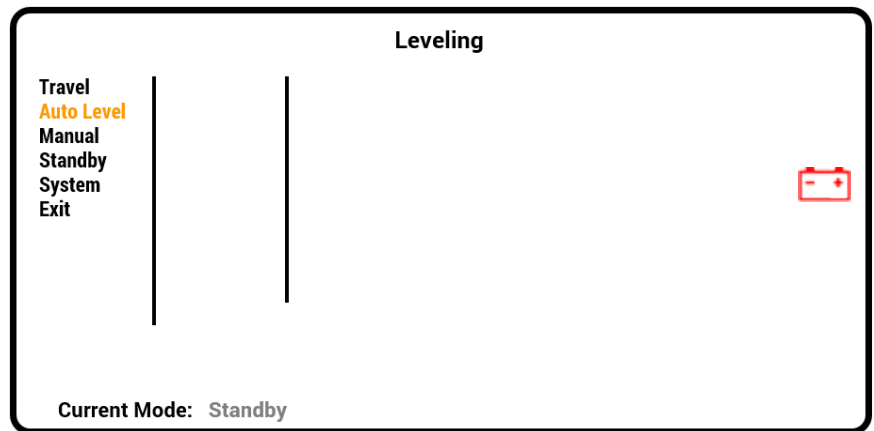

# SYSTEM COMMANDS

The following System screens are used mainly by service personnel under the guidance of Valid's technical support staff.

## **Level Zero**

---

The Level Zero screen allows you to adjust the level reference used when the vehicle is in auto leveling mode. The system uses the level reference when in auto or manual mode to level the vehicle when parked on unlevel ground.

## **Travel Zero**

---

The Travel Zero set screen allows you to set the accelerometer reference used by the suspension control system when the system is in Travel mode.

## **RH (Ride Height) Setup**

---

The RH (Ride Height) Setup screen puts the suspension control system in a constant height adjustment mode. This allows the adjustment of the ride height sensors to set the normal vehicle travel height.

## **Tag Setup (if equipped)**

---

For vehicles with a tag axle that is controlled by the Trueline Leveling System, the Tag Setup screen allows the adjustment of various parameters relating to tag pressure.

## **Config**

---

The Config screen provides access to the leveling system configuration settings.

# STATUS MESSAGES

The Suspension/Leveling screen can display a number of messages and alerts. These are located at the right of the level display, in orange.

## Twist

---

If the **TWIST** indicator is on, the twist limits have been reached during manual leveling. To recover, either perform an automatic level, or manually raise or lower the low or high corners to un-twist the vehicle.

**Note:** The system will prevent either a manual raise or lower of a corner if that direction increases the twist beyond the allowable limit.

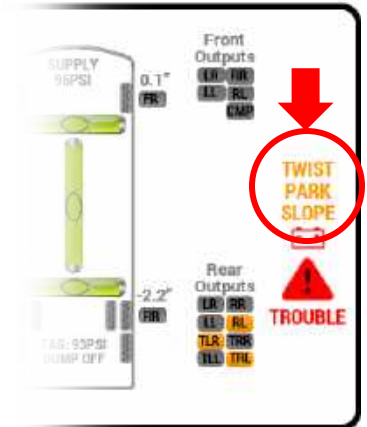

## Park

---

The park indicator illuminates if the park brake is on. It flashes if an attempt is made to level the vehicle without the park brake engaged.

## Slope

---

If the **SLOPE** indicator is on, leveling is not possible because the ground has excess slope. Move the vehicle to another location. See page 9 for more information.



5320 48 Ave. SE • Salmon Arm, BC, Canada V1E 1X2

Phone: 250-832-6477 • 24-hour Emergency Technical Support: 250-804-1247

Fax: 250-832-7746 • [sales@validmanufacturing.com](mailto:sales@validmanufacturing.com)

[www.validmanufacturing.com](http://www.validmanufacturing.com)

# Pre-Trip Inspection

---

## Pre-Trip Inspection

- Check fluid levels & add as necessary
- Check tire inflation pressure
- Look for fluid leaks

Before starting your motor home daily, a few things must be checked. By doing so, you ensure that a safe trip is in order and lessen your chances of experiencing difficulties while on the road.

- Check the tires for proper inflation pressure and any damage. Also check the inner duals. Refer to the air pressure charts in this manual for proper inflation pressures.
- Look for fluid leaks under the motor home. This can prevent any serious problems from occurring later.
- Check the coolant level in the reservoir and add a 50/50 mix of coolant and water if necessary. This reservoir can be found on the rear of your vehicle.
- Check ELC (Extended Life Coolant Extender) and freeze point every 30 months or 150,000 miles. Recharge as required.

### Caution

If the water temperature in your engine is greater than 120 degrees, do not remove the radiator cap! You could be severely burned.

- Approximate COOLING SYSTEM CAPACITIES – does not include the heater core or other auxiliary systems added by coach manufacturer
- Cummins ISV – Rear radiator 48 quarts or 12 gallons
- Check transmission fluid level
- Check engine oil level
- Check for small animals in engine compartment, such as squirrels and cats
- Check the power steering fluid reservoir

### Check fuel/water separator

- Check fuel/water separator and drain any water or contamination that may be present.



## PRE-TRIP INSPECTION

After you have completed your inspection, you may now start your engine. Turn the key to the run position and wait for the wait to start light (in some cases it may read “Inlet heater”) to turn off. You may now start the engine. ***Never use ether or any other starting fluids to start the electronic engine. The inlet heater can ignite the fumes and cause an explosion in the air inlet system.*** Once you have started the engine, monitor your gauges carefully. Make sure that the oil pressure rises within 15 seconds. If it does not, shut down the engine and call a repair facility to determine the cause.



Figure 4-1: Filter Restriction Indicator

- Check air filter restriction indicator (Figure 4-1)

Brand New Air Cleaner  
10” to 12” of Vacuum

- Engine air cleaner element should be changed when the air inlet restriction indicator reaches 25 inches of vacuum **or** every 12 months, whichever occurs first. Reset after engine starts for true reading.

# Warranty

---

## Warranty

- **Engine**

- Cummins ISV, 5 years or 100,000 miles

- **Transmission**

- Allison 2100 MH Series: 5 Years or 200,000 miles

- **Chassis**

- 3 Years or 50,000 miles

- **Drive Train**

- 3 Years or 50,000 miles

- **Suspension**

- 3 Years or 50,000 miles

- **GHG Emission Components**

- **Tires:** Tiffin Motor Homes, Inc. warrants that its vehicles are designed, built and equipped with tires that conform, at the time of sale, with requirements of vehicle manufactures whose vehicles are designed to meet applicable 2014 - 2019 U.S. Environmental Protection Agency and National Highway Traffic and Safety Administration greenhouse gas and fuel efficiency standards, and those tires are free from defects in material and workmanship which cause the vehicle to fail to conform with the vehicle manufacture's requirements for a period of 2 years or 24,000 miles, whichever occurs first. Claims for failures under this coverage are filed directly to the tire manufacture.

**WARRANTY**

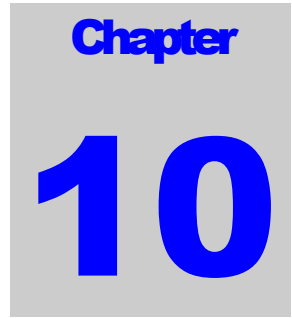

# **Allegro Owner's Club**

---

## Allegro Owner's Club



The Allegro Owner's Club is an organization for Allegro motor home owners that provide access to rallies and more. Several rallies are organized throughout the year. The rallies are normally a package deal which includes your campground fees, entertainment, several meals, transportation to and from planned activities, suppliers exhibits, plenty of door prizes, and much more. Service technicians from Tiffin Motorhomes, Inc. are also available to do minor repairs to rally participants motor homes as well as sales representatives who can answer questions about your motor home and other issues. Of course, free time is scheduled into each rally for your personal leisure and interests.

If you purchase a new unit, Tiffin Motorhomes pays for your first year of membership. Club members are also eligible to purchase insurances at discounted rates as well as other companies that provide discounts to our Club members.

Local chapters are also set up throughout the country. These local chapters generally have monthly campouts which allow you to meet new friends and share information.

The Allegro Club also publishes a quarterly newsletter, *Side Roads*, which keeps members informed about rallies, caravans, chapter news, safety information, factory news, and much more. *Side Roads* is published in March, June, September, and December.

Allegro Club merchandise is also available at the Allegro Store in Red Bay, AL. You can purchase shirts, caps, jackets, and other accessories emblazoned with the Tiffin name brands.

For more information on the Allegro Club or to join, please contact membership coordination at 256-356-8522 or visit our web site: [www.tiffinsideroads.com](http://www.tiffinsideroads.com).