

Wherever You Go...We Go!

Tiffin Motorhomes

Experience a lifetime relationship!



2007

Allegro Bay

Owner's Manual

Tiffin Motorhomes, Inc.

105 2nd Street NW

Red Bay, AL 35582 U.S.A.

Phone: (256) 356-8661 E-Mail: info@tiffinmotorhomes.com

[20060831]



TIFFIN MOTORHOMES, INC.

105 2nd Street NW ♦ Red Bay, Alabama 35582 U.S.A.

Allegro Bay Owner's Manual

ALLEGRO BAY OWNER'S MANUAL

TIFFIN MOTORHOMES, INC.

Allegro Bay Owner's Manual

© Tiffin Motorhomes, Inc.
105 2nd Street NW, Red Bay, AL 35582 U.S.A.
Telephone 256.356.8661 • Facsimile 256.356.8219
E-Mail: info@tiffinmotorhomes.com

DISCLAIMER

Many of the features and appliances described in this manual may or may not be reflected in the actual motor home purchased, depending on the options and models selected by the motor-home owner. All items, materials, instructions, and guidance described in this manual are as accurate as possible at the time of printing. However, because of Tiffin Motorhomes' ongoing and dedicated commitment to excellence, improvement of Tiffin's motor homes is a continuing process. Consequently, Tiffin Motorhomes reserves the right to make substitutions and improvements in its makes and models of motor homes without prior notification. Substitutions of comparable or better materials, finishes, appliances, instrumentation, and instruction may be made at any time it is deemed prudent to provide the customer with the best possible motor home meeting the customer's requirements.

Copyright © 2003 by Tiffin Motorhomes, Inc. -- all rights reserved

Printed in the United States of America: Fourth U.S. Printing: September, 2004

Table of Contents

<hr/> Chapter 1 <hr/>		Fire Safety	2-8
General Information		Fire Extinguisher	2-9
Delivery	1-2	Smoke Detector	2-9
Dealer Responsibilities	1-2	Emergency Exit Window	2-10
Customer Responsibilities	1-2	Parking Procedures	2-10
Tiffin Motorhomes Limited Warranty	1-3	Towing Hitch	2-10
Major Equipment Manufacturers	1-3		
Warranty Service	1-4	<hr/> Chapter 3 <hr/>	
Owner's Information Package	1-5	Heating & Air Conditioning	
Customer Relations	1-5	Furnace	3-2
Specification Labels	1-5	Air-Conditioning System	3-3
Weighing Procedures for the Allegro Bay	1-7	Thermostatic Controls	3-4
Weight Distribution of the Motor Home	1-7	Liquid Propane (LP) Tank	3-4
		LP Tank Filling Practices	3-5
		LP Gas Regulator	3-6
		CO/LP Gas Detector	3-6
<hr/> Chapter 2 <hr/>			
Driving & Safety Instructions		<hr/> Chapter 4 <hr/>	
Safety Considerations	2-2	Major Appliances & Accessories	
General Warning	2-2	Refrigerator	4-2
Prior to Departure	2-3	Microwave/Convection Oven	4-5
Driving	2-4	Air-Filtration Fan	4-5
Fuels for the Motor Home	2-5	Cook Top and (Optional) Oven	4-5
Liquid Propane (LP) Gas System	2-6	TELEVISION SYSTEM OPERATION	4-7
LP Gas Regulator	2-7		
LP Distribution System	2-7		
Recommended Precautionary Practices	2-8		

Television Antenna	4-7
Television Satellite Dish Control	4-8
Television Sets	4-8
Home Theater System	4-9
Audio-Video Control Console	4-9
AM/FM/CD Stereo System	4-9
Cable & Telephone Jack	4-12
Water Heater	4-13
Water Heater Storage	4-14
Pressure-Relief Valve	4-15
CB Radio System Antenna Connection	4-15
Rear-View Camera Monitor System	4-16
Washer / Dryer (Optional)	4-18
Carbon Monoxide/LP Gas Detector	4-18

Chapter 5

Cabinets & Furniture

Cabinets	5-2
Furniture	5-3
Bedroom Area	5-5
Select Comfort Mattress (Optional)	5-5

Chapter 6

Structural Features

Chassis Features	6-2
Alignment	6-2

Chapter 7

Electrical Features

General Information	7-2
Circuit-Breaker Boxes	7-2
Auxiliary Start Switch	7-3
Battery Inspection and Care	7-3
Battery Disconnect Panel	7-5
120-Volt AC (VAC) Receptacles	7-5
12-Volt DC (VDC) Receptacles	7-6
Ground-Fault-Circuit Interrupt (GFCI)	7-6
Electrical Generator	7-6
Inverter / Converter	7-7
Automatic Transfer Switch	7-8
Resettable Circuit Breakers	7-8
Fuse Blocks	7-9
Seven-Pin Towing Connector	7-10

Chapter 8

Slide-Out Features

SLIDE-OUT OVERVIEW	8-2
General Considerations	8-2
Operating Precautions	8-2
Extending the Slide-Out Room	8-3
Retracting the Slide-Out Room	8-3
Manual Operation: Slide-Out Room	8-4

Chapter 9

Exterior Features

Towing Hitch	9-2
Exterior Sides	9-2
Security Lights	9-2
Roof & Ladder	9-3
Hydraulic-Leveling Jacks	9-3
Leveling Control System	9-4
Electric Steps	9-6
Mirrors	9-8

Water Heater Bypass System	11-6
Fresh Water Lines	11-7
WASTEWATER SYSTEMS	11-7
General Information	11-7
Toilet	11-8
P-Traps	11-8
Black-Water Holding Tank	11-9
Gray-Water Holding Tank	11-9
Wastewater Disposal	11-9
Sewer Connection and Camping	11-10
No-Fuss Flush	11-11
Exterior Shower	11-11

Chapter 10

Interior Features

Bedspread	10-2
Flooring	10-2
Ceiling	10-3
Window Treatments	10-3

Chapter 12

Construction Features

Construction Notes	12-2
Typical Floor Plan	12-2

Chapter 11

Plumbing & Bath Features

FRESH WATER SYSTEM	11-2
Monitor Panel	11-2
Kitchen Sink	11-2
Bath, Sink, Shower & Accessories	11-2
Water Pump	11-3
City Water Connection	11-4
Filling the Fresh-Water Tank	11-4
Sanitizing	11-5
Water Filter (Optional)	11-6

Chapter 13

Windows, Awnings, Vents & Doors

Windows	13-2
Awnings	13-2
Vents	13-5
Doors	13-6

Chapter 14

Routine Maintenance

EXTERIOR CARE	14-2
Washing	14-2
Waxing	14-3
Seals	14-3
Proper Sealants for Application	14-3
Striping and Decals	14-4
Roof Care and Maintenance	14-5
Moisture Management	14-5
Tire and Tire Safety Information	14-9
Tire Pressure	14-23
INTERIOR CARE	14-27
Carpet	14-27
Fabrics	14-28
Walls and Ceiling	14-29
Dashboard	14-29
Woodwork and Floors	14-30
Countertops	14-30
Accessories	14-31
Detectors	14-31
Condensation	14-31
ROUTINE MAINTENANCE SCHEDULES	14-32
Monthly	14-33
Every Three Months	14-33
Every Six Months	14-33
Annually	14-33
Winterizing	14-33
De-Winterizing	14-36

Motor Home Owner's Data Sheet	15-2
Motor Home Maintenance Record	15-3
Motor Home Maintenance Record	15-4
Motor Home Maintenance Record	15-5
Motor Home Maintenance Record	15-6
Motor Home Maintenance Record	15-7
Motor Home Maintenance Record	15-8
Motor Home Maintenance Record	15-9

Chapter 15

Maintenance & Data Charts

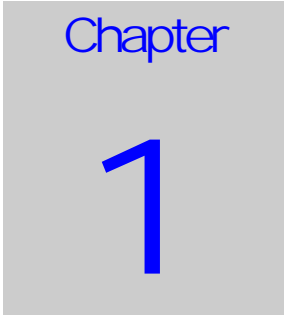

GENERAL INFORMATION

TIFFIN MOTORHOMES: "WHEREVER YOU GO, WE GO"

Delivery

Throughout the entire manufacturing process your Tiffin motor home has been regularly inspected by our qualified personnel to assure you of the finest product of the highest quality, **without exception**. However, the final inspection at our factory is not to be the last one. The pre-delivery inspection and system check that your dealer performs are the final inspections done to your particular motor home prior to your actually receiving your new Allegro Bay motor home. Your dealer is also available to assist you in understanding the warranties and completing the necessary forms to activate the warranties for the various appliances and accessories installed in your motor home.

Dealer Responsibilities

1. A **pre-delivery inspection and systems check** is performed to assure a thorough inspection of the motor home and to assure the proper operation of all factory-installed components.
2. A **customer walk-through** is performed to familiarize the new customer with the motor home, its systems and components, and their proper and safe operation.
3. Delivery of the **Owner's Information Package** which contains warranty cards and registrations for the vehicle and all factory-installed components from other vendors and suppliers to Tiffin Motorhomes. The detailed operation instructions and maintenance instructions on these components are also included in this package.
4. Assisting the customer in **completing the registration forms** to avoid loss of warranty coverage. The dealer should review the limited-warranty provisions with the customer to stress the importance of completing the warranty cards and registration forms for the components in the motor home to enable the manufacturers to receive them within the prescribed time limits.
5. Providing the customer with **information regarding warranty and non-warranty work** on the vehicle and its separately warranted components.

Customer Responsibilities

The customer is responsible for regular and proper maintenance of the motor home. Properly maintaining your motor home will prevent conditions arising from neglect that are not covered by your Tiffin Motorhomes limited warranty. The maintenance guidelines in this manual and any other, applicable manual(s) should be followed. It is your responsibility and obligation to return the vehicle to an authorized dealer for repairs and service.

To assist you in avoiding problems with your motor home, it is recommended that you do the following:

1. **Read the warranty.** Go over it thoroughly with your dealer to make sure you understand all the terms and conditions of the warranty.
2. **Inspect the motor home;** do not accept delivery until after you have gone through the motor home with the authorized Tiffin Motorhomes dealer. Ask questions about anything unfamiliar to you. Be sure to review and check each item on that list and make sure that the Tiffin Motorhomes dealership does the same. Do not sign the checklist until you have done this completely. **NOTE:** Some variations may exist between the sales literature and the actual specifics of your particular Allegro Bay in the areas of measurements, weights, or quantities. Ask the dealer to define all the differences, as desired or required.
3. **Please ask questions** about anything you don't fully understand about your Allegro Bay; Tiffin Motorhomes is here to serve you and assure that you have all the information necessary for your safe and enjoyable use of your new motor home.
4. When you are taking delivery, **set an appointment for adjustments.** This appointment should be within two weeks after you accept delivery.
5. You are responsible for and expected to **use your Allegro Bay in a responsible, safe manner.** Please take the time to familiarize yourself with the proper operation of the motor home and all its features before you attempt to use your motor home on the road.

Tiffin Motorhomes Limited Warranty

The Tiffin Motorhomes limited warranty was provided to you by your authorized Tiffin Motorhomes dealer during the pre-delivery inspection. When you inquire about your Tiffin Motorhomes warranty, please refer to this document. Should you need or desire an additional copy or other information, please contact:

Tiffin Motorhomes, Incorporated

105 2nd Street NW

Red Bay, AL 35582 U.S.A.

Telephone: (256) 356-8661; Facsimile: (256) 356-8219

E-Mail: info@tiffinmotorhomes.com

Tiffin Motorhomes will be pleased to send you an additional copy or any other information requested, as may be warranted.

Major Equipment Manufacturers

The following list is a compilation of the vendors and suppliers of the major subsystems and components of your Allegro Bay. This list is provided for your convenience and is not meant as a complete substitution of the

literature and accompanying “how to contact us” information supplied by those vendors and suppliers in your Owner’s Information Package [see below for particulars]. Where appropriate, web-site information is provided for computer users.

- Atwood Mobile Products (800) 646-8557 www.atwoodmobile.com
 - CO Alarm (800) 880-6788 www.atwoodmobile.com
 - LP Gas Detector (815) 877-5700 www.atwoodmobile.com
 - LP Gas Water Heater (815) 877-5700 www.atwoodmobile.com
- Denso Corporation (248) 350-7500 www.globaldenso.com
- Flexsteel Industries (319) 556-7730 www.flexsteel.com
- HWH Corporation (800) 321-3494 www.hwhcorp.com
- Kwikkee (541) 942-3888 www.kwikkee.com
- Norcold, Inc. (800) 543-1219 www.norcold.com
- Onan Corporation (612) 574-5944 www.onanindiana.com
- Panasonic Corporation (800) 211-7262 www.panasonic.com
- Power Gear (800) 334-4712 www.powergear.com
- RV Products (Coleman A/C) (316) 832-3400 www.airxcel.com
- Sharp Corporation (800) 237-4277 www.sharp-usa.com
- Suburban Manufacturing Co. (423) 775-2131 www.suburbanmanufacturing.com
- The Dometic Corporation (219) 294-2017 www.dometic.com

For those wishing more information (e.g., locations of authorized subsidiaries), the following web site, www.rvamerica.com/data/s_alist.htm, should be helpful. This site provides complete, alphabetic listings of all suppliers and vendors for all contemporary recreational vehicles and motor homes.

Warranty Service

If any warranty service may be required, that service needs to be completed during the warranty period (basic warranty: 12 months or 12,000 miles). Tiffin Motorhomes warrants its unitized construction for 10 years and its laminations for 5 years. Any service work performed after the expiration of the Tiffin Motorhomes warranties WILL NOT be covered by those warranties. Exceptions may be made, on an individual basis, to this deadline on account of the unavailability of parts and/or service appointment time where work is to be

performed. However, don't rely on the possibility of an exception; please schedule any desired in-warranty work before your warranty expires.

Owner's Information Package

The Owner's Information Package (Figure 1-1) includes valuable documents about your Allegro Bay and its components and systems. The Tiffin Motorhomes Allegro Bay Owner's Manual does not cover every possible detail of equipment—standard and/or optional—installed on or in your vehicle. By consulting the booklets and instruction manuals included in the Owner's Information Package, you will learn how to operate, maintain, and troubleshoot these items safely and effectively. As with all valuable documentation, please keep them in a safe, secure place for your later use and consultation. When you complete and mail to the respective manufacturer(s) any warranty/guaranty registration card(s), make a photocopy of both sides of each card prior to mailing and keep the photocopy in your permanent records for your Allegro Bay Motor Home.



Figure 1-1. Owner's Information Package

Customer Relations

If you wish to schedule maintenance or service or wish to order parts, you should notify your local authorized Tiffin Motorhomes Dealership to set up an appointment. If you are unsure of the location of your nearest, authorized Tiffin Motorhomes Dealership; please access the Tiffin Motorhomes website at www.tiffinmotorhomes.com and then click on the "find a dealer" button, then click on the appropriate section of the United States nearest your location, then select the closest dealer by clicking on that dealer's number—the dealer's name, address, and telephone number will then be displayed for your use.

Specification Labels

There are two main numbers used to identify your Allegro Bay. The Vehicle Identification Number (VIN) is the legal identification of the completed vehicle. The VIN is the number used by the state for vehicle identification and registration. Additionally, there is a Tiffin Motorhomes identification number. The Tiffin number is needed when you plan to make an appointment for service or to order parts through your Tiffin Motorhomes Dealership or Service Center. This number can be found on the side of the dashboard. A typical sample of this identification label is shown in Figure 1-2.

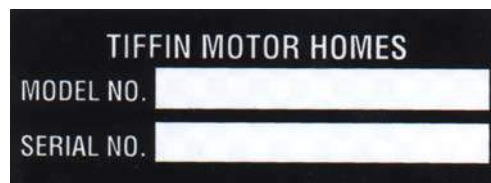

Figure 1-2. Tiffin Serial Number

Another label affixed to your Allegro Bay is the Recreational Vehicle Industrial Association (RVIA) Weight Label (Figure 1-3) which is a required label for your vehicle. Tiffin Motorhomes, a manufacturer-member of

RVIA, has the obligation to disclose the following information, at minimum, to the purchaser of the motor home:

- An indication of the contents of the RVIA weight label affixed to the motor home.
- A concise explanation of the following items:
 - Vehicle Weight (VW) distribution.
 - Proper weighing techniques to be used to weigh the vehicle.
 - Specific definitions for the following terminology:

Recreational Vehicle Industrial Association (RVIA) Weight Label			
Timb Motorhomes, Inc. 105 2 nd Street NW Red Bay, AL 35567 U.S.A. Telephone: (256) 356-8661 Facsimile: (256) 356-8119 E-Mail: info@timbmotorhomes.com			
Motor Home Weight Information			
Model Name: 400H Freightliner	Serial Number: 3403	Year: 2002	
Weight Terminology and Definitions			
GVWR	Gross Vehicle Weight Rating is the maximum permissible weight of this fully-loaded motorhome.		
UVW	Unloaded Vehicle Weight is the weight of the motorhome as produced at the factory, with full fuel, engine oil, and coolants.		
SCWR	Sleeping Capacity Weight Rating is the manufacturer's design load number of 154 lbs. multiplied by 54 persons (70 x 154 lbs.).		
CCC	Cargo Carrying Capacity is equal to GVWR minus each of the following: UVW, full fresh (potable) water weight, and weight of water heater, if applicable, and GCWR.		
GCWR	Gross Combination Weight Rating means the maximum allowable combined weight of the motorhome and any towed trailer or towed vehicle.		
Cargo Carrying Capacity (CCC) Computation - Example			
Item	Description	Weight (Lbs.)	Weight (Kg.)
GVWR	Gross Vehicle Weight Rating	14,250	6,436
UVW	Unloaded Vehicle Weight	9,253	4,202
Fresh Water	Fresh water weight of 154 gallons @ 8.3 lbs/gallon (3.8 kg/gallon)	1,276	576
Water Heater	Weight of 30 lbs. (13.6 kg)	30	14
GCWR	Gross Combination Weight Rating	12,641	5,732
CCC*	Cargo Carrying Capacity	2,660	1,207
*Based on the maximum weight of the motorhome and any towed trailer or towed vehicle.			
WARNING: Consult Owner's Manual(s) for specific weighing instructions and towing guidelines including auxiliary brake requirements for any towed trailer or towed vehicle.			

Figure 1-3. RVIA Weight Label

- **Gross Vehicle-Weight Rating (GVWR)** – This is the maximum permissible weight of the motor home when it is fully loaded.
 - **Unloaded Vehicle Weight (UVW)** – This is the weight of the motor home, as built at the factory, with full fuel, engine oil, and coolants. The UVW does not include cargo, fresh water, LP gas, or any dealer-installed accessories.
 - **Cargo-Carrying Capacity (CCC)** – This is the maximum weight of all occupants including the driver, personal belongings, food, fresh water, waste water, LP gas, tools, tongue weight of towed vehicle [if any], dealer-installed accessories, and the like. The CCC is equal to or less than the GVWR minus the UVW.
 - **Gross Combination-Weight Rating (GCWR)** – This is the value specified by the chassis manufacturer as the maximum allowable loaded weight of the motor home with a towed trailer and/or vehicle [if any].
 - **Sleeping-Capacity Weight Rating (SCWR)** – This is the maximum weight capacity of the combined number of persons (i.e., number of people multiplied by 154 pounds per person) permitted to sleep within the vehicle.
 - **Gross Axle-Weight Rating (GAWR)** – This is the maximum allowable weight for a single-axle system, as measured at the tire-ground interfaces. The GAWR considers the weakest link in the tire, wheel, brakes, hubs, axle, springs, and attaching parts. To illustrate, if the axle is rated at 15,000 pounds and the tires are rated at 3,200 pounds each as a dual installation; then the maximum GAWR would be 12,800 pounds for a four-tire vehicle
- Towing Guidelines – Specific weighing instructions and guidelines are furnished in the Owner’s Manual (see below for a general overview and also Chapter 2 for more specific details).

Weighing Procedures for the Allegro Bay

To weigh the motor home properly, the motor home should be level when the weighing process is performed. Your Allegro Bay motor home has been designed and built in compliance with the recommended limits of the major-component/system suppliers to provide a realistic CCC. However, it is up to the final user to provide even distribution of the loads brought into the motor home to prevent uneven loading.

Once the motor home is loaded, it can be taken to any drive-on scales or individual-wheel scales to determine that the final weight is within specified limits for this motor home. The procedure which can be used is as follows:

First, drive the motor home onto the scales so that all wheels are on the scales; this provides the gross vehicle weight (GVW) of the motor home and can be recorded as such. The GVW should not exceed the GVWR specified for the motor home.

Second, drive the motor home so that the front wheels are off the scales and only the rear wheels remain on the scales; this provides the total weight of the motor home, save for the front axle. This weight should not exceed the total rating of the axles remaining on the scales. The front axle weight is determined by subtracting the weight from the GVW that was obtained in the first step which was performed earlier. The result should not exceed the listed front-axle weight rating. For a more thorough weighing of the motor home, Chapter 14 contains more specific axle-weight determinations.

Weight Distribution Throughout the Motor Home

To assure the maximum stability of the motor home under static (i.e., parked) and dynamic (i.e., moving) conditions, the distribution of the items to be carried and stored within the motor home and in the storage bays underneath the motor home should be performed in such a manner to strive for reasonably even side-to-side and front-to-rear dispersion of the entire weight of both the stored items and also the driver and expected passenger(s) during transit. This process will assure that the motor home is not “lop-sided” in weight distribution (i.e., all the stored weight on one side and/or mainly towards the front or the rear)—keeping a center of mass of the motor home essentially centered on a front-to-rear and side-to-side basis will also provide better control of the motor home when it is in motion.

Driving & Safety Instructions

Safety Considerations

Prior to using your motor home, especially for the first time or after a long period of non-use, please read thoroughly all the instructions in both the Owner's Manual and the chassis-manufacturer's manual before attempting to operate your motor home. There are several safety considerations which you should realize and follow while your Allegro Bay is in motion. These safety considerations, as well as others meant to preclude any damage to the motor home, are listed in this chapter. Besides the driver, it would be helpful for the passengers to be familiar with these safety considerations and precautions, too.

Warning

Before your motor home is to be operated, be sure that you have read the entire Owner's Manual and that you fully understand the equipment on your motor home and how to use that equipment safely.

General Warning

Warning

Any portable, fuel-burning (e.g., charcoal, propane, butane, wood) equipment must not be used inside the motor home. Any use of such equipment inside the motor home may readily cause fires and/or asphyxiation by carbon-monoxide poisoning. Further, such unauthorized use would probably invalidate your motor-home insurance policy.

In general, there are several "common-sense" safety precautions that should be taken every time the motor home is to be used on the road; these precautions include:

- Only seats with seat belts should be used while the motor home is in motion; those seat belts should be worn by all people (driver, passengers) in the motor home at that time.
- While the motor home is moving, lock all seats in the forward-facing position to provide maximum safety for the users.
- While the motor home is moving, no one inside should ever stand or kneel on seats (e.g., young children).

- In the majority of states, it is the law that seat belts must be used (fastened snugly about the chest and hip areas), anytime the motor home is in motion, to provide desired protection in the event of a crash.
- Any fire extinguisher(s) should be inspected on a monthly basis to assure that each extinguisher is properly charged and ready for operation.
- Any smoke and/or carbon-monoxide (CO)/liquid propane gas (LP) alarm(s) should be regularly inspected and tested. If being used for the first time, the smoke and/or CO/LP gas alarm should be properly activated and fresh batteries installed before the motor home is placed into service. Prior to any trip, the smoke and/or CO/LP gas alarm(s) should be manually tested to assure their correct operation. Immediately replace any defective components (e.g., weak batteries). Never sleep in a motor home not having functional smoke and/or CO/LP gas alarm(s). Should an alarm or detector fail when in transit, a suitable replacement can be purchased at most hardware stores, superstores, or drug stores.
- While the motor home is moving, the sleeping facilities are not to be used.
- In the event of an emergency, be sure that everyone in the motor home is familiar with all escape exits (doors, escape window). Do not use the emergency window as a routine exit; this is strictly to be used for emergency purposes only. When the motor home is parked, be sure that the emergency exits are not inadvertently blocked.

Prior to Departure

For your continued safety and convenience, the following is a representative “check list” designed to assure your safety while driving:

- Clean all windows, mirrors, and light lenses (front, back, side) to assure that you can “see” and “be seen.” Reposition any mirrors or other fixtures to provide an unobstructed view (front, sides, and back) from the driver’s seat (see Chapter 9 for details). When another driver takes over, reposition the mirrors and other fixtures for that driver.
- Remove or secure all loose fixtures (e.g., awnings, flags, antennas, portable lights) to keep them from falling from the motor home when the motor home is in motion.
- Make a “walk-around” visual inspection of the motor home to note any irregularities (e.g., loose trim) or problems (e.g., under/overinflated tires; abrasions or nicks on the tires); correct noted problems accordingly.
- Check all exterior storage-compartment and generator-compartment doors to make sure that they are properly latched and locked. If need be, check inside all exterior compartments to make sure that all cargo and equipment are properly secured so that they won’t work loose and become hazards during sudden starts and stops.

- Check tires for proper inflation (i.e., cold inflation pressure: 100 psig or so); if the motor home has not been used, make sure that the “cold inflation” pressure is maintained. If the motor home has very recently been used, make sure that the “hot inflation” pressure (see the tire-manufacturer’s literature to determine appropriate “hot inflation” pressure) is maintained. All tire pressures should be within 1-2 pounds (psig) of each other, unless weight loading dictates otherwise (see Chapter 14, Section 14-23).
- Examine wheel lug nuts to assure their proper tightness. If any lug nuts were found to be loose, first check the fit of the wheel to the hub to make sure that the wheel is not mis-mounted which would produce a “wobbly” wheel when the motor home is in motion, then tighten the lug nuts.
- Check all fluid levels (e.g., engine oil, transmission fluid, coolant, power-steering fluid, brake fluid, battery fluid [if applicable], windshield-washer solvent) to assure correct levels are maintained. Fill any low reservoirs, as needed.
- DO NOT SUBSTITUTE any other fluids for specified oils, transmission fluid, brake fluid, or other hydraulic fluids—in most instances, substitutions are not acceptable and may void warranties.
- Prior to starting the motor-home engine, make sure that all lines (e.g., water, sewer) and electrical-power cords are disconnected and properly stowed.
- Assure that the leveling jacks are in the “travel” position.
- After entering the motor home, make sure that the electrically-actuated, retractable step has properly operated to retract the step fully before starting the engine of the motor home.

Driving

Various adjustments need to be made to assure the driver’s comfort and the safety of the motor home before starting and moving the motor home; these include:

- The driver should adjust the driver’s seat, the tilt steering, the exterior rear-view mirrors, and the instrumentation panel lighting (if nighttime) for the driver’s comfort and safety. This is especially important for first-time use so that the driver may become accustomed to the “feel” of the motor home and know where the various adjustments are located “before the fact”; not after some need arises while the motor home is in service.
- The driver should be familiar with all gauges, instruments, switches, and indicators on the instrument panel prior to driving. Should the driver encounter any “unknowns” on the panel, they should be investigated (via the Owner’s Manual or Owner’s Information Package) prior to



Figure 2-1. Driver’s Side Dashboard & Instrumentation Console

departure so that the driver fully understands these items and their functions.

- One should never adopt a “learn as you go” philosophy, as there are too many controls and switches to be understood before the motor home is actually used. Please take the time to become thoroughly familiar with the entire instrument panel prior to using the motor home on the road.
- Do not operate the cruise-control function during any extreme weather situations (e.g., snow, ice, sleet, heavy rain) or when road conditions are hazardous (icy, snowy, winding roads, city traffic) or when a constant speed of the motor home is not possible or if traffic conditions don’t warrant such.
- Avoid driving the motor home through any standing water. If deep enough, such water can wet the brake pads and cause fading of the brakes (i.e., loss of braking power) and lead to excessive sliding or pulling to one side or another. If one has driven through standing water, at the first opportunity safely to do so, check the braking action. If braking has degraded, lightly apply the brakes to allow the brake pads to dry—don’t use the motor home when the braking function is significantly reduced.
- Know the limits of operation of the motor home. Don’t try to achieve excessive speeds, climb overly steep hills, traverse overly long grades, attempt to use the motor home as an “off-the-road” (OTR) motor home, rapidly switch lanes, or rapidly accelerate or decelerate the motor home. When in doubt about the handling characteristics of the motor home, consult your chassis manual for information.

Fuels for the Motor home

Your motor home is designed to have several types of petroleum-derived fuels used in the routine operation of the motor home—these require prudent and safe handling to assure safety of the motor home and its occupants; namely:

- Anytime the motor fuel (i.e., gasoline or diesel depending on what the required model’s fuel; see Figure 2-2) or the LP tank is to be filled, the motor home engine is to be turned off, all pilot lights must be extinguished, and appliances turned off. Further, during any filling operation or connecting/disconnecting of any LP tanks, a NO SMOKING policy should always be observed. In a similar manner, any other comparable devices of the motor home users (e.g., butane camp-lights, propane lights and grills) should be treated in a similar manner to assure the safety of all concerned.



Figure 2-2.
Gas Tank

Warning

Liquid Propane (LP) gas containers, gasoline, or other flammable liquids are not to be placed or stored inside the motor home because a fire or explosion may occur. LP gas containers are equipped with safety valves that may relieve



Figure 2-3. Liquid Propane Tank

excess pressure by discharging gas into the atmosphere—any containment of that vented LP gas constitutes an explosive hazard.

- NEVER use an open flame to test for LP gas leaks or to examine the fluid levels in the fuel tanks.
- After filling any LP system, immediately replace and secure all protective covers and caps.
- After closing the LP valve, close and securely latch the LP door to prevent unintentional access or damage.
- NEVER connect natural gas to the LP gas system—LP gas and natural gas are not interchangeable.
- NEVER use any other “burning” equipment (e.g., charcoal grills, wood stoves, butane lights, propane lights inside the motor home—doing so may cause fires and/or asphyxiation.

Liquid Propane (LP) Gas System

A warning label is conspicuously located near the LP gas container; that label reads:

Warning

DO NOT FILL the LP Container(s) to more than 80% of capacity.

Any overfilling of the LP gas container(s) can result in uncontrolled gas flow—a prime condition for a fire or explosion. The LP container should only be filled to 80% of its capacity; the remainder of the cylinder space is a vapor space to contain expansion of that liquid when subjected to varying ambient-temperature conditions. Filling in excess of 80% of the liquid volume of the container reduces that vapor space and, thus, creates a condition for possible over-pressurization of the container.

All LP appliances in your motor home have been approved for use in motor homes by a nationally recognized testing laboratory (i.e., UL and CSA certified). When properly used, LP gas is a clean-burning fuel which can be dependably used. In actuality, the LP container contains liquid propane under high pressure. The liquid, when it passes through the tank valve to a lower pressure, vaporizes into a gas, and then passes through a regulator to maintain a constant pressure. This gas, then, is the actual fuel distributed through the LP-gas manifold system to the LP-based appliances used in your motor home.

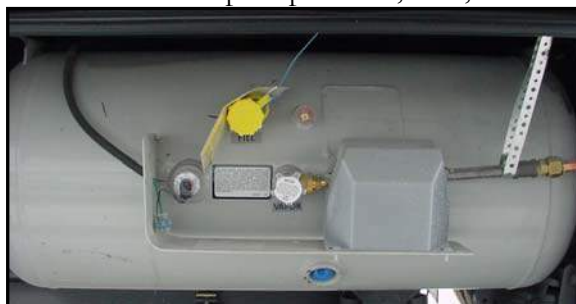

Figure 2-4. Liquid Propane Tank

LP-appliance-lighting problems are typically caused by an improperly adjusted gas regulator. NEVER attempt to adjust or reset the gas regulator yourself, as an authorized service technician is needed to make these adjustments. As a good preventive-maintenance activity, the regulator should be checked semi-annually by a service technician and also before every extended trip.

Even though the LP-gas system is leak-checked and verified at the factory at the time of manufacture, normal usage (travel vibrations, etc.) could loosen the fittings. Consequently, it is wise to check the gas fittings periodically for leak tightness. One can daub some leak-detector solution (e.g., a “liquid-soap”-like solution) on all the fittings, connections, and junctures when the system is under pressure. Should there be any leaks; small bubbles will appear at any leak sites.

Generally, loose fittings can be tightened (with “non-sparking” tools) to stop the leaks. If this process doesn’t work, then one must shut off the main gas valve at the LP cylinder(s) and immediately consult an authorized service technician to determine what repairs are necessary. Leaks may also be detected by noting the sulfurous odor (i.e., rotten eggs) associated with LP gas [caused by an additive added to the normally odorless LP gas]. DO NOT search for a leak by using a match or open flame.

Warning

When the motor home is not in use, be sure to close the main LP gas valve at the tank. When the LP gas tank is to be refilled, close the main valve to preclude the chance of the pilot lights possibly igniting fumes from the LP fuel. As some LP-gas appliances (e.g., refrigerator, furnace, water heater) have Direct Spark Ignition (DSI) systems, it is very important that these appliances be turned “off” when the LP gas is “off.” The DSI boards will continue to work (i.e., generate an ignition spark) even when there is no LP gas available.

LP Gas Regulator

The LP gas regulator is the most critical element of the LP-gas distribution system. The regulator converts the high-pressure LP gas from the tank into a reduced-pressure LP-gas supply suitable for use in the various appliances in the motor home. One should regularly inspect visually the regulator system. If any damage or corrosion is noted, contact an authorized service technician to inspect and repair or replace the regulator.

Do not attempt to adjust the regulator yourself; the regulator has been pre-set at the factory. Only a qualified LP service technician using specialized equipment should adjust the regulator.

LP Distribution System

The primary LP distribution system in the motor home is a pipe manifold running the length of the motor home. The secondary distribution lines running from this main distribution system are usually copper tubing with flare fittings. If any of the gas lines break, do not attempt to splice them—always run new lines to

maintain the safety of the motor home. It is strongly recommended that only qualified service technicians perform this work. Remember, the main valve at the LP gas tank must be closed whenever any gas appliance is to be installed, removed, or serviced—this process prevents LP gas leakage which could result in a possible harmful explosion. If the odor of LP gas (i.e., rotten eggs) is ever detected, immediately discontinue use of any gas appliances and seek the services of a qualified service technician.

Recommended Precautionary Practices

The following practices are recommended to assure continued safety and reliability of the LP gas system; these are, of course, representative; not necessarily exhaustive. In all cases, use common good sense in the use of the LP system.

- Visually inspect the LP fill valve before any refueling operation to look for foreign materials or debris; remove, as necessary, to assure a leak-tight connection.
- Prior to any re-fueling operation of the LP gas system, shut off all the pilot lights.
- NEVER, under any circumstances, check for LP gas leaks with any type of open flame; doing so would probably cause an explosion and subsequent fire.
- Periodically inspect visually the entire LP gas distribution system; do so at least semi-annually and before any major trips. Should problems be noted, seek the services of a qualified service technician to make necessary repairs and perform any maintenance.

Warning

The LP gas distribution system in your motor home is designed for liquid propane (LP) gas ONLY. DO NOT attempt to connect and use any natural-gas or butane-gas systems with this LP gas system.

Fire Safety

As with any enclosed system containing the three required conditions for fire (i.e., combustible materials, oxygen, ignition sources), there will exist the possibility of fire. Tiffin Motorhomes has taken every precaution and design practice to minimize or negate this possibility, but the final determination rests with the owner and user of the motor home. Accordingly, it is in the best interests of the owners, users, and their guests to be aware of basic fire-safety practices and procedures and those particular features that Tiffin Motorhomes has provided for fire safety.

Fire Extinguisher

The Allegro Bay is equipped with a fire extinguisher (located inside next to the main entrance door; see Figure 2-5) rated for both Class B (i.e., grease, gasoline, diesel fuel, flammable liquids) and Class C (i.e., electrical) services—these are typically the most likely types of fires to be expected in motor homes. Read and understand the accompanying owner’s manual on that extinguisher (found in your Owner’s Information Package) and remember the location of the extinguisher. In an emergency, you won’t have the time or presence of mind to do so then. You may wish to purchase other extinguisher(s) [e.g., for the rear interior; around the generator outside; etc.], at your discretion.

These types of fire extinguishers are pressurized, mechanical devices and require that appropriate care be used in their safe storage and use. The owner’s manual will provide necessary guidance for the proper storage, handling, and use of the extinguishers. Prudent preventive maintenance suggests monthly inspection of any fire extinguisher to assure that it is sufficiently pressurized (i.e., the needle on the gauge is in the “normal” zone) and that the mechanical components are not blocked in any way.



Figure 2-5. Fire Extinguisher

Do not test a fire extinguisher by partially discharging the unit—this will cause a loss of pressure and may lodge some fire-retardant materials in the valve mechanism and cause the extinguisher to continue to vent slowly down to zero pressure. Rather, if an extinguisher is ever partially used; continue its use until the unit is completely discharged then have the fire extinguisher fully recharged at an appropriate service center (one can call any fire department for information on having an extinguisher recharged in that particular locality). **DO NOT** wait a long time to recharge an empty fire extinguisher; you’ll never know when it may be needed.

Should a fire occur inside or around the motor home, ***evacuate the motor home quickly and calmly***—do not panic. In the event of heavy smoke or extensive flames, keep low (crawl if you must) and make your way to the nearest exit (door, emergency window) and leave. If the fire involves a fuel source (e.g., motor fuel, LP gas); consider the probability of an explosion and move sufficiently far away to minimize personal harm. If such is available, immediately place a call to the local fire department (or ask someone nearby to do so) to report the fire. Consider the cause and the consequences of the fire and the risks associated with possibly fighting the fire yourself before trying to extinguish it—**DO NOT** expose yourself or others to unnecessary danger.

Smoke Detector

The Allegro Bay motor home is equipped with a battery-operated smoke detector located on the ceiling in the living area of the motor home. Read and become familiar with the operation and periodic testing of this detector. The smoke detector should be tested on a weekly basis, before each trip, and after any period of storage of the motor home.



Figure 2-6. Smoke Detector

If a low-battery condition is noted or the alarm “chirps” to indicate a low-battery condition, immediately replace the battery. It would be prudent to keep replacement batteries in the motor home for any in-transit replacements so that the smoke-alarm capability is never compromised. **DO NOT** disable the smoke detector for any transient, false alarm (e.g., cooking smoke, dusty

furnace, tobacco smoke); rather, ventilate the motor home with fresh air and the alarm will reset.

Emergency Exit Window

In the rear of the motor home, there is an emergency exit window in the bedroom—this window is designed for an emergency exit when it is not practical to exit by the door [also an emergency exit] in the front of the motor home. This window is readily noticeable by its red handle and the red “EXIT” label on that window.

To use this window as an emergency exit, lift the handle and push outward on the window. As required, the window can be closed by pulling the window inwards and then lowering the handle to latch the window back in place. When the motor home is to be parked, it would be wise to note where this window will be so that this exit won’t be blocked (e.g., against a tree, pole, or wall).



Figure 2-7. Emergency Exit

Parking Procedures

To park the motor home in any unfamiliar terrain, examine the prospective site for surface irregularities, slopes or inclines, and other discontinuities (i.e., stumps, rocks, external connections for power/water/sewage) and also examine the area immediately above the proposed parking site for obstructions (e.g., tree branches and limbs, signs, overhead wiring).

If the motor home is to be backed into the proposed parking site, strive to have that site be on the driver’s left-hand side, as this will allow the driver to watch the rear of the motor home. Back up slowly and use the side mirrors (and the optional back-up camera) as a guide or, better yet, have another person outside provide supplemental guidance to help park the motor home.

When the motor home is finally situated, shift the transmission into the “park” position and engage the emergency brake and then turn “off” the engine. Activate the leveling-jack system (see Chapter 9 for more detail) to level and stabilize the motor home.

If the motor home is to be powered externally, connect the 120 VAC power to the motor home. Turn “on” the LP gas valve at the LP tank. Connect the fresh-water supply and sanitize the water systems (see Chapter 11), as needed. Connect the waste drain hose to the external sewer hook-up. Start the refrigerator, water heater, and furnace; as warranted. Light the oven pilot light (if so equipped), as needed. Certain appliances, such as the refrigerator, will not work properly if the motor home is not level, so be sure to complete the motor home-leveling process before activating any of the appliances.

Towing Hitch

The Allegro Bay is fully capable of towing typical motor vehicles; the motor home is equipped with a Class 3, 5,000-pound towing hitch supporting a tongue weight of 500 pounds and an associated wiring connector. The motor home is capable of towing light loads and instructions for such are found in the chassis-manufacturer’s literature in the Owner’s Information Package provided with the Allegro Bay.

As a towed vehicle being pulled by a motor home represents a greater complexity in driving for the driver (e.g., driving, turning, backing, parking), one should not attempt such on the road without first practicing such (e.g., in a vacant lot) to master these skills.

The total weight of the motor home and any vehicle towed by that motor home must not exceed the Gross Combined Weight Rating (GCWR). When the motor home is being weighed, remember to account for anticipated occupants and their locations in the motor home. **Any vehicles to be towed by the motor home should have adequate active braking.**

The wiring connector provided is a standard seven-pin connector (see Chapter 7 for specific details on this connector).



Figure 2-8. Towing Hitch

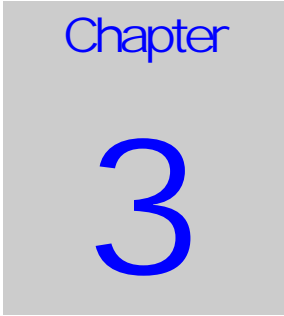

Heating & Air Conditioning

Furnace

Warning

Never attempt to modify the furnace. To do so may cause fire, explosion, carbon-monoxide poisoning, or asphyxiation. If the furnace is malfunctioning, immediately shut the unit “off” and call a trained service technician to make necessary repairs as soon as possible.

The Allegro Bay motor home is equipped with a forced-air furnace fueled by LP gas. The furnace is controlled by the wall-mounted thermostat (Figure 3-1) located inside the motor home—this thermostat controls both the heating and air conditioning for the motor home.



Figure 3-1. Thermostat

In the heating mode, the furnace heats air which, in turn, is circulated through ductwork in the floor of the motor home. If any obstruction(s) block the floor vent(s) or air-return register, then the furnace will not function properly. Therefore, any items stored under the cabinets should be carefully stowed to prevent damaging or crushing the furnace ducting or blocking the warm-air return.

When a furnace is being used for the first time, there may be an initial “burn-off” of manufacturing compounds or residues left on the heat exchanger or in the ductwork which could produce odors, fumes, and possibly some smoke. This occurrence is normal and should not cause concern, unless it persists for an excessive amount of time.

To minimize the after-effects of this “burn-off” process, the initial use of the furnace should be done with all the doors and windows open to permit normal air circulation to dissipate these possible odors and fumes.

For routine operation of the furnace, set the thermostat to the desired temperature setting and then turn “on” the thermostat; in about a minute, the furnace should begin to operate and warm or hot air should be coming through the ductwork.

To shut down the furnace, turn the thermostat to the “off” position. Even though the thermostat may be turned “off,” the furnace system will continue to run for about a minute or so to permit a gradual cool-down of the heating system which is normal.

On a regular basis, thoroughly clean the complete furnace and air-tube passageways to remove dust, lint, and any other possible obstructions. Leak-test the entire LP gas system at least semi-annually. Also check and clean the air-blower system annually.

Any access hatches to the furnace are for authorized service personnel only, as there are no user-serviceable parts on the furnace. Accordingly, do not attempt to tamper with the interior of the furnace.

Warning

Be cautious when washing the exterior of the motor home; water should never be sprayed directly into the furnace vent. Should any water be forced beyond the rain baffles into the furnace vent, the furnace may rust which, in turn, may cause improper combustion and produce unwanted by-products of combustion.

Before the beginning of each travel season, the furnace should be thoroughly cleaned and inspected. Any obstructions, debris, or lint which may obstruct free air flow or impede the operation of the air-circulation system should be removed. For example, accumulated dust or lint could possibly obstruct the orifices for the pilot light or may accumulate on the blower blades and unbalance the operation of the blower. Additionally, any debris in the ductwork, when heated by the furnace, could emit unpleasant odors or possibly become a fire hazard.

Consequently, the furnace system (including ductwork) should be periodically cleaned; annually is recommended unless the motor home is subjected to dust levels significantly greater than average; in which case more frequent cleaning is recommended. The Owner's Information Package provides recommended cleaning tips and procedures; when needed, a more thorough cleaning should be performed by a qualified service technician.

Air Conditioning System

The factory-installed air-conditioning system is designed for 120 VAC power supplied either from the external power hookup cord or from the generator. Any unnecessary interior heat loading (e.g., exposure to direct sunlight for long periods of time; transmittance of sunlight through the windows) will work the air conditioning system harder and may compromise the desired results. Accordingly, if the air conditioning system is to be used, park the motor home in a shady location whenever possible and close drapes on those windows exposed to direct sunlight. Additionally, any heat-producing sources (e.g., oven, unnecessary lights) within the motor home will work against the air conditioning system; so strive to minimize their use.

The air conditioning system is the major consumption device of electrical power in the motor home. When this system is being used in an RV park, cumulative use of these air-conditioning systems by the resident motor homes can create, at times, a bigger demand for electrical power than is actually available. Accordingly, at such times, a "brown-out" condition may arise—this is when the AC voltage normally available drops to a lesser value (e.g., 10-20% below normal or more).

"Brown-out" conditions cause appliances to draw greater currents to make up for the reduced voltage; thereby causing circuit breakers to trip or fuses to blow. Under such conditions, your own motor home

is not at fault; simply reset your breakers and/or replace your fuses. Should such conditions continue, one may wish, in turn, to reduce the electrical load (in this case, turn “off” the air conditioning system for awhile) or start the electrical generator.

To cool the motor home, the thermostat inside the Allegro Bay is used—this is the same thermostat which controls the furnace functions (described earlier). The air-conditioned, cooled air is emitted through the vents which are located in the roof throughout the entire coach. The discharge and return air vents run parallel, front to back, on the ceiling. Note that the return vents are similar to the air conditioning vents. This system allows even distribution for the returns instead of forcing an excess amount of return air through two smaller openings. The even return system takes more of the hot air from the motor home, thereby providing cooler air throughout the unit. The air conditioning vents that are mounted on the ceiling are round vent filters (Figure 3-2) that need to be periodically checked for dust accumulation. When dust has accumulated on the filters, remove them and wash in a mild detergent and warm water.



Figure 3-2. Round Vent/Filter

Thermostatic Controls

The following is a brief overview of how best to use the thermostat (Figure 3-3). For more detailed instructions, please consult the thermostat literature in the Owner’s Information Package. The thermostat will have three switches that operate the Fan Mode, Thermostat, and Fan Speed.

To operate the Fan mode: There are three levels—Auto, On, and Off.

To operate the Thermostat: There are four levels—Cool, Off, Gas Heat, or Electric Heat.

To operate the Fan speed: The levels range from low to high. One can move the setting the level of power desired.



Figure 3-3. Thermostat

A switch that allows one to increase or decrease the temperature of the coach is also positioned on the thermostat. The user can set an exact temperature with this switch.

NOTE: There is an approximate 2-minute time delay after selecting cooling function for refrigerant compressor to start.

NOTE: If the Comfort Control is turned “off” or the thermostat loses power (i.e., power failure), the air-conditioning system will resume operation at the last settings programmed into it when electrical power is restored.

Liquid Propane (LP) Tank

The Allegro Bay is equipped with an ASME (American Society of Mechanical Engineers)-approved LP tank (Figure 3-4) which is equipped with an automatic pressure regulator. This tank contains liquid

propane fuel under high pressure. As this fuel passes through the main valve and through the regulator, it is converted into a gas and its pressure is reduced to a safe level for use within the motor home. A LP gas-distribution system distributes the gas to those appliances using such in the motor home. The “heart” of this LP gas distribution system is the regulator and that regulator should only be adjusted by a qualified service technician. Most of the problems encountered in lighting the pilots of these appliances are caused by regulator mis-adjustments.

The major component of the LP gas supply is a manifold pipe which runs lengthwise underneath the motor-home floor. From this manifold, the various gas appliances are connected by copper tubing with flared fittings so that connections and disconnections can readily be made, as needed.

Should any of the secondary tubing develop a leak, either on the tubing proper or at the fittings, do not attempt to splice any of these lines. Instead, have a qualified service technician run a new length of tubing to the appliance of concern and then have that line leak-tested before placing it in normal operation again.



Figure 3-4. Liquid Propane Tank

To remove, repair, or replace any gas-operated appliance; always close the main gas valve at the LP tank—this measure will provide an additional element of safety to prevent gas leakage and possible, subsequent explosion hazards. However, if a gas leak is noted or suspected, turn “off” the main valve and keep the LP gas system “off” until that system is inspected by a qualified service technician as soon as possible. Do not delay in addressing any possible gas leaks with appropriate service because of the inherent hazards to safety.

Warning

When the motor home is not being used, the main LP gas valve must be turned “off.” Also, turn “off” the main valve when the LP gas tank is to be refueled to avoid the possibility of ignition of fuel fumes by the pilot lights. All gas valves on the gas-operated appliances with Direct Spark Ignition (DSI) should also be in the “off” position during refueling and/or maintenance operations. DO NOT store LP, motor fuel, propane, butane, or other flammable liquids inside the motor home, as these represent a very real fire hazard and possible threat to life.

LP Tank Filling Practices

Any LP gas tank associated with the motor home should never be filled to more than 80% of total capacity; filling should always be done only when the motor home is leveled. If the motor home is not

level, the tank may be overfilled (i.e., more than 80% of capacity) and, thus, subject the motor home to possible fire or explosion from resultant uncontrolled gas flows.

LP Gas Regulator

As noted earlier, the LP gas regulator is the “heart” of the LP gas distribution system. This regulator reduces and controls the pressure of the gas on the outlet end to provide a constant supply of gas at a constant pressure to the gas-operated appliances. The regulator has a vent to relieve excess pressure on the inlet side of the regulator, should excess pressure develop in the gas tank and connecting gas line to that regulator inlet. The vent would normally release the excess LP gas to the atmosphere until the over-pressurization condition is eliminated.

This vent should be regularly checked to assure that it is not clogged or obstructed. If that vent is blocked from normal operation, component or system failures may result. If periodic visual inspection indicates any sign of corrosion or degradation, contact a qualified service technician to repair the regulator as soon as possible; DO NOT operate the LP gas system with any faulty component in place.

Occasionally, the inherent moisture in the LP gas can cause a freeze-up of the regulator when the gas passes through the regulator. The regulator reduces the high pressure of the gas on its inlet side to a reduced pressure on its outlet side by permitting a controlled expansion of the gas through the regulator—this gas expansion necessarily cools the gas (by means of the Joule-Thompson effect) and, if cooled enough, may cause any moisture content to freeze. To minimize or negate this possibility, always keep the main valve to the LP gas tank closed when the system is not in use.

When the LP tank is empty, keep the main valve closed until re-filling is to be performed—this process will keep any moisture-laden air from back-flowing into the gas system and trapping unwanted moisture in the LP gas tank. If an empty LP gas tank has been exposed to the atmosphere for an extended time, let a qualified service technician purge the tank before its next filling operation.

Important

When a LP gas regulator is installed or re-installed, the regulator must always be installed with the gas diaphragm vent facing downwards. For more information, consult the manufacturer’s literature in your Owner’s Information Package that came with the motor home.

CO/LP Gas Detector

Since LP (i.e., liquid propane) gas is denser than air, the LP gas will naturally settle to the lowest point in an enclosed space—in the motor home, this would be the floor. Because of this fact, the CO/LP gas detector (Figure 3-5) is necessarily mounted close to the floor. To activate the LP-gas sensor on this

detector for the first time, remove the sensor activation strip, if such was not performed during the pre-delivery inspection. Please check the CO/LP gas detector to verify that the detector was properly activated and is ready to provide the necessary protection. If in doubt, please contact any qualified service technician for more detailed assistance.

Warning

Liquid Propane (LP) is extremely flammable and, when contained, explosive when mixed with air. Consequently, never check for leaks in LP gas lines or appliances with an open flame or sparking devices. Do not use any ammoniated or chlorinated household-type detergents for “bubble testing” possible leak sites—these detergents may generate fissures or cracks on the metal tubing (e.g., copper) and flared fittings (e.g., brass). Have your LP gas system leaks repaired **ONLY** by a qualified service technician; do not attempt these yourself. Keep the main valve to the LP gas tank closed and all appliances turned “off” when the motor home is stored. If any of the valves do not close “leak-tight” by hand, have those valves examined and repaired by a qualified service technician. **DO NOT**, under any circumstances, attempt to use a faulty LP gas system and/or appliances as such represents a safety hazard.

If the alarm persists in re-arming and giving further alarms; ventilate the motor home (by opening doors and windows) and then check for possible LP gas leaks. If the leak cannot be readily found, then close the main valve to the LP tank and turn “off” all gas appliances and then take the motor home to a qualified service technician after the ventilation process is concluded and the doors and windows again shut.



Figure 3-5. CO/LP Gas Detector

Major Appliances & Accessories

Refrigerator

The Allegro Bay motor home will contain a refrigerator manufactured by either of these two manufacturers: Norcold, Incorporated or The Dometic Corporation. As each of these operates somewhat differently from the other, each will be individually addressed in this section to permit the motor-home owner to use the one installed in his motor home. **Note:** If the 12V system is off the refrigerator will not work.

When the refrigerator is in the “LP gas” mode, make sure that the main LP gas valve is in the “on” position before attempting to start the refrigerator. Please note that the refrigerator is equipped with a semi-automatic energy selector (AES) control system which can set automatically to switch between a 120-volt AC system or a LP-gas operation system.

Warning

The majority of LP gas appliances used in motor homes normally vent to the outside of the motor home. When your motor home may be parked in close proximity to a fuel pump (i.e., during re-fueling operations), it is possible that the fuel fumes could enter this type of appliance and possibly be ignited by the burner flame thereby causing a fire or explosion. Accordingly, please use extreme caution when re-fueling the motor home.

The 12-VDC power supply (e.g., 12 VDC system of the motor home, auxiliary battery, or converter) must be “on” for the proper operation of the refrigerator. For electrical operation of the refrigerator, either the external electrical power line must be connected to the motor home or the on-board electrical generator must be running to provide the necessary 120-volt AC power. To operate the refrigerator in the LP-gas mode, the main LP gas valve must be “open.”

Norcold Refrigerator

To start the Norcold refrigerator (Figure 4-2), on the control panel (Figure 4-1) press the main power “on/off” button [right-hand button] to the “on” position which starts the refrigerator in the “automatic” mode. When this is done, if 120-volt AC is available to the motor home, the AC mode indicator light will light and indicate that the AC power is available to the motor home. However, if the 120-volt AC is not available, then the gas mode indicator light will be illuminated indicating that the refrigerator will be operating on the LP gas



Figure 4-1. Norcold Control Panel



Figure 4-2. Norcold Refrigerator

supply. To turn the refrigerator “off,” push the “on/off” button for two seconds to shut down the refrigerator.

The “temp set” button [left-hand button in Figure 4-1] controls the temperature adjustment of both the freezer and the refrigerator compartments; the selections chosen will not change if the operation mode (AC power or propane gas) changes. To select the desired degree of coldness push and hold the “temp set” button—this will step through numbers “1” through “9” where “9” the coldest setting attainable. Hold the button until the desired setting number is realized, then release the button.

The “mode” button {middle button in Figure 4-1} controls the operation mode of the refrigerator—there is one automatic mode and three manual modes of operation. To select the desired mode, push the “mode” button and release it when the desired mode (e.g., **AU** = automatic, **AC** = AC-powered, **LP** = propane gas mode, **DC** = DC electric).

In the **automatic (AU) mode**, the refrigerator automatically selects the most efficient energy source available for operation. Should a more efficient energy source become available during the operation of the refrigeration, the automatic mode will then select it for continued operation of the refrigerator.

When 120 VAC power is available, it will be selected and the display will show “AU” “AC” flashing in the display. In about ten seconds, the display goes “off” and only a power indicator light remains “on.” If there is not any 120 VAC power available, the display will flash “AU” “LP” to indicate that LP gas is the energy source being used.

Should the refrigerator be a three-way model and neither 120 VAC nor LP gas is available, the display will flash “AU” “DC” to indicate that the refrigerator is being powered by a DC energy source (the batteries). Should there be any improper operation of the refrigerator, the display will show various error codes—the user should become familiar with those codes in the manufacturer’s literature for the refrigerator.

Manual operation can also be selected by pressing the “mode” button for the desired type of operation.

In the “LP” mode (either manual or automatic), on initial start-up of the refrigerator, ignition of the propane gas may not occur for 30 seconds. If gas ignition doesn’t occur within 30 seconds, the gas safety valve in the refrigerator will close. Then either the refrigerator selects another mode of operation (in the automatic mode) or an audible alarm sounds (in the manual LP mode) which will remain “on” until the “mode” switch to cancel that alarm. In this case, push the “on/off” switch two times to stop and re-start the refrigerator; then attempt the LP gas ignition process once more. If the gas still doesn’t ignite, check the gas supply line and consult a qualified service technician.

Should a failure occur, the display will indicate various failure codes to help the owner determine what fault or faults may have occurred so that they may be expediently addressed. Not all failure codes will have an accompanying audible alarm, so the owner should not rely solely on the audible alarm for fault indications.

NOTE: To operate the refrigerator in the LP-gas mode, the 12 VDC power source must be operational; otherwise, the refrigerator will not operate on LP gas. If the refrigerator is operating in the LP-gas mode and the 12 VDC power is disconnected, the refrigerator will cease operating.

On the refrigerator, the “thermostat” function controls both the gas and electrical operations—this eliminates the necessity of resetting the temperature each time one switches from gas to electrical service or vice versa. Press the temperature selector button until the light near the desired setting is illuminated (“1” through “9”). After initial start-up, the “thermostat” should be moved from the coldest setting to the desired setting, which is usually around mid-range on the scale (i.e., “4” or “5”).

Dometic Refrigerator (Optional)

To start the Dometic refrigerator (Figure 4-4) [optional, side-by-side shown in picture], press the main power “on/off” button [left-hand side of panel shown in Figure 4-3] to the “down” position. Then press the “temperature selector” button [right-hand side of the panel]



Figure 4-3. Dometic Control Panel

represents “coldest”).

For **automatic mode** operation, press the ‘AES/Auto/Gas’ mode selector [to the right of the “on/off” switch] to turn “on” the “AES/Auto” lamp [just above that switch]. If 120 VAC is available, the AC mode indicator lamp will illuminate to indicate that the 120 VAC is being used. If 120 VAC is not available, the Gas indicator lamp will illuminate indicating that the control has automatically switched to the GAS mode.

If the Check indicator lamp [center of Dometic control panel] illuminates and the Gas mode indicator lamp is “off,” the controls have failed to ignite the burner in the GAS mode. GAS operation may be reset by pressing the main power “on/off” button first to the “off” position and then back to the “on” position. Finally, press the “temperature selector” button to select the desired temperature level in the refrigerator.

For operation in the **LP Gas mode**, press the “AES/Auto/Gas” mode selector button to turn “off” the “AES/Auto” lamp. The GAS mode indicator lamp will then illuminate to indicate that the refrigerator is now being powered by LP gas. Within 45 seconds the burner should be ignited and the unit operating normally. However, on the initial start-up of the refrigerator, it may take longer than 45 seconds to allow trapped air to be purged from the LP gas line.

If the gas doesn’t ignite within 45 seconds, the CHECK indicator lamp will illuminate and the GAS mode indicator lamp will go out. To reset when the CHECK indicator lamp is illuminated, press the main power “on/off” button first to turn “off” the refrigerator, then again to turn “on” the refrigerator again. NOTE: If successful operation isn’t realized after one or two additional tries, do not continue attempting to use the GAS mode.



Figure 4-4. Dometic Refrigerator

Finally, press the “temperature selector” button to choose the desired level of coldness in the refrigerator. After initial start-up, the thermostatic control should be moved from the “coldest” setting to the desired temperature range (usually “3”—the mid-point on the scale).

To turn the refrigerator “off,” press the main power “on/off” button to the “off” (i.e., UP) position—this will shut off all DC power to the refrigerator including the interior light.

Microwave/Convection Oven

The Allegro Bay contains a microwave/convection oven (Figure 4-5). All microwave ovens operate on 120-volt AC electrical power, supplied either by the external electrical hookup or by the onboard electrical generator in the motor home. Between the power source(s) and the microwave oven is a surge protector to protect the unit from electrical transients and power surges.



Figure 4-5. Microwave/Convection Oven

Touch-pad controls on the microwave oven are used for operating the oven (i.e., cooking temperature, mode, power level, and cooking time). For basic operating instructions on the proper use of the microwave and convection oven, please consult the specific manual in the Owner’s Information Package.

Air-Filtration Fan

In the Allegro Bay, the “exhaust” or air-filtration fan is built into the microwave and its function is to filter the air only; it does not exhaust to the outside. This range hood is equipped with a multi-speed fan and a light for convenient use. The hood should be used whenever any cooking is performed to filter any airborne cooking residues and heated air.

Additionally, the range hood can be used as supplemental filtration of other odors and gases including tobacco smoke, candle fumes, and related vapors. The range hood contains filters which can be removed and cleaned or replaced to assure sustained normal operation. Consult the particular owner’s manual contained in the Owner’s Information Package.

Cook Top and (Optional) Oven

The Allegro Bay is normally equipped with a two-burner recessed, Princess cook-top (Figure 4-6). The cook-top has two removable covers which provide additional counter space when the cook-top isn’t being used.



Figure 4-6. Two-Burner Cook Top

To use the cook-top, remove the covers and temporarily store them where they won’t be in the way and then follow the directions for proper use. When use of the cook-top is over, allow sufficient

time for the unit to cool before re-installing the covers over the cook-top.

To light a cook-top burner, push down on the knob (for that burner) and turn counterclockwise to the “ignite” position. Continue to hold down the knob fully until the spark ignites the gas and then continue to hold the knob down for another 5-10 seconds (this additional time is required for the thermocouple to be heated sufficiently to activate the safety mechanism—the thermocouple will automatically cut “off” the gas flow if the burner goes “out”). Then release the knob and rotate it to the desired cooking setting. To turn the cooking flame “off,” turn the knob clockwise to the “off” position. For additional safety and use precautions, be sure to read the manufacturer’s owners manual before using the cook-top for the first time.

The optional oven (Figure 4-7) has a piezoelectric ignition source, rather than a pilot light, to start the oven. To light the burners, turn “on” the gas control knob, wait a couple of seconds, then push the red DSI (direct-spark ignition) button until a flame appears.

If the burner does not start after a few attempts, discontinue the process, let the released gas dissipate, then try the process again. The burner knobs operate in a counter-clockwise (CCW) manner and must be gently pushed inwards as they are being turned.

If the oven doesn’t have a piezoelectric ignition source, light the oven by pushing inward on the oven control knob and rotating it CCW to the “pilot on” position, then light the oven pilot light located at the back left-hand side of the oven burner—this may take a few seconds until the air in that line is purged and replaced with the LP gas. Do not attempt to adjust the oven pilot light as it has been factory-adjusted and factory-set. To extinguish the oven pilot light when use of the oven is concluded, push inwards on the oven control knob and turn that knob clockwise (CW) to the “off” position.



Figure 4-7. Oven (Optional)

If the Allegro Bay is equipped with an optional oven, that oven comes with a multi-burner cook-top having a bi-fold, countertop cover matching the same décor as the counters in the motor home. This bi-fold cover both provides protection to the burners when they are not in use and additional counter space, as needed.

Before any cooking on the cook-top is attempted, the bi-fold cover must be folded up and back from the cook-top so that the cooking surface is free and unobstructed. Do not replace the cover immediately after using the cook-top; wait until those surfaces are cool to the touch before replacing the cover. Never use the cook-top range when the motor home is in motion.

As a safety feature, the following label will be noted in the cooking area:

Warning

DO NOT USE cooking appliances as a heating source for the motor home. Cooking

appliances require adequate fresh air for safe operation. Before using any cooking appliance, make sure that an overhead vent or window is open and/or turn “on” an exhaust fan.

Remember that any LP gas-operated appliance in the motor home will be consuming oxygen in the motor home. If the motor home is totally closed during such operation, the oxygen level may be reduced (and the associated carbon monoxide level may be increased) thereby causing possible harm or death to the occupants through asphyxiation. Always use these appliances with proper ventilation.

DANGER – Notice -- DANGER

IF YOU SMELL GAS, YOU SHOULD IMMEDIATELY:

Extinguish any open flames, pilot lights, and all smoking materials. Do not touch or operate any electrical appliances or switches. Immediately shut “off” the gas supply at the main tank valve or supply connection. Open doors, windows, and other ventilation openings (then immediately leave the motor home!) to allow entrapped LP gas to dissipate. Have the LP gas system checked to locate and fix the source(s) of the leakage.

TELEVISION SYSTEM OPERATION

Television Antenna

The Allegro Bay motor home is equipped with a retractable antenna (Figure 4-8) for television (TV) reception of all VHF (i.e., channels 2-13) and UHF (i.e., channels 14 upwards) channels. To deploy the antenna for proper reception of TV signals, turn the TV-antenna crank clockwise (CW) to raise the antenna; this should take about 10-15 turns until some resistance is noted.

Once the antenna has been raised, slowly rotate the antenna to receive the best picture on the channel of choice—this rotation is accomplished by pulling down on the directional handle with both hands until it disengages from the ceiling plate and then rotating the antenna until optimal reception is realized. There is an antenna power booster switch (left-hand side of the audio-video control console—see Figure 4-12) which, when pushed, strengthens the signals to be received.



Figure 4-8. Television Antenna

If your location is within a metropolitan area, you may need to rotate the antenna for

each different station desired to aim the antenna towards each particular station. If the location of the motor home is remote from any metropolitan area; the antenna, once positioned for a particular station, should be adequate for all other stations capable of being received from that particular area. Some experimentation may be required to determine the “best” setting for each location of the motor home and the stations desired to be viewed.

Prior to moving the motor home, the TV antenna must be retracted. To lower the antenna, rotate the directional handle until the pointer on that handle is aligned with the pointer on the ceiling plate; then turn the elevating crank counter-clockwise (CCW) about 10-15 turns (until some resistance is noted) to lower the antenna and lock it into its retracted position for travel. **DO NOT** partially lower the antenna; it must be either fully deployed (raised) or retracted (lowered)—any intermediate position will lead to damage to the antenna itself or to the motor home.

When the TV antenna is raised and adjusted, if the TV reception is weak, blurred, or of inferior quality; examine the connections from the TV to the antenna and make sure that the power-boost switch (see Figure 4-12) is actually “on.” If the symptoms persist, then consult your authorized service dealer.

Television Satellite Dish Control

The RV may be equipped with a TV Satellite Dish control system (Figure 4-9) to permit access to direct-satellite television. The television-receiver dish is controlled by a hand-cranked mechanism which deploys the dish and permits its rotation so that the desired signals may be received. Follow the directions in the Owner’s Manual for this dish-control mechanism to obtain the best orientation of the satellite dish for desired television reception. Remember, that any additional movement of the motor home after the satellite dish control has been set may possibly cause loss or degradation of satellite-television



Figure 4-9. TV Satellite Dish Control

reception. In this case, please re-adjust the satellite dish to re-align that dish for optimal television reception.

Television Sets

The television sets (Figure 4-10) furnished with the motor home are cable-ready; one is in the overhead bay above the dash and the other is in the bedroom, depending on the particular floor plan of the Allegro Bay purchased. The televisions are powered by 120-volt AC electricity; therefore, the motor home must either be plugged into an external source of AC power or using on-board power from the generator.



Figure 4-10. Television Set

Detailed operation of the television(s) is provided in the accompanying owners manuals found in the Owner’s Information Package included with the motor home. Generic operations of the television would include a basic “on/off” switch, volume “up/down” control, channel “up/down” selector, and menu “up/down” selector—these functions are found both on the

television set itself and on the accompanying remote that comes with the television set.

If the motor home has been wired for satellite TV, there should be an interior jack or jacks and an exterior jack to connect the satellite system. Consult your owner’s manual for the satellite system to determine the correct connections to be made.

Home Theater System

The motor home may have a contemporary, home theater system (Figure 4-11) which offers true surround sound for the front television and also when DVD programs are viewed featuring the Dolby Surround Sound system. As this home theater system offers many entertainment options, it is worthwhile to



Figure 4-11. Home Entertainment Theater System

read the manual thoroughly before attempting extensive use of this system. This system will also play CDs and MP3 disks, among other media

Audio-Video Control Console

The Allegro Bay contains an audio-video control console (AVCC) (Figure 4-12) to enable one to select where the TV signal is routed (i.e., front and/or rear televisions). The TV antenna booster switch is located on the left side of this console; when engaged (i.e., “on”), this switch strengthens the received signals to improve reception. To make the desired selection, simply press the



Figure 4-12. Audio-Video Control Console

appropriate button(s) to select what is to be viewed and where. The front television is selected by pushing button “TV 1” and the rear television (and outside television, as warranted) is selected via button “TV 2.” One can view a different channel or input source on each of the television systems. For instance, if one should select the “ANT” option for the front television, any channels available on the antenna system can be viewed on the front television. At the same time, if one selects “VCR” for the rear television, any DVD recorded program can be viewed on the rear television. The “AUX” position permits connection to an external cable system, satellite dish, video games, or VHS video cassette player.

AM / FM / CD Stereo System

Your motor home will be equipped with a Magnadyne AM/FM/CD Stereo system (Figure 4-13). To properly operate the stereo system, it is important that you read the information provided with the system.

To turn the unit on and off, push the “POWER” button.

To select a Play Source such as the radio, CD or optional equipment such as the Sirius Satellite Radio, external CD changer, or auxiliary sources,



Figure 4-13. AM/FM/CD Stereo System

push the “Mode” button to choose the desired play source.

Sound Settings:

Volume: Rotate the VOLUME knob left or right.

Bass, Treble, Balance or Fader: Push the VOLUME knob to scan between the different sound controls. Once the desired function is in the display area rotate the knob left or right to achieve the desired level.

Equalizer: Push the EQ button to choose between preset equalizer settings: Classic, Rock, DSP Off (digital sound processor off), Flat, Pop and Jazz, as indicated in the display area.

Mute: Push the MUTE button to mute the volume level. Press again to return to previous volume level.

Loudness: Push the LOUD button to boost high and low tones at low volume levels.

Sirius Satellite Radio (optional):

Note: If your Sirius tuner is not activated, call 1-888-539-747487 (SIRIUS) to activate. The Sirius Tuner ID Number (ESN) is required during the activation process. Follow the instructions below to access the Sirius Tuner ID Number (ESN):

1. Push the MODE button until “SIRIUS” appears in the display area.
2. Push the TUNE button until “DIRECT” appears in the display area. Wait a few seconds and “CH 000” will then appear in the display.
3. Push the BAND button and the first 4 digits of the 12 digit Sirius Tuner ID Number (ESN) will be displayed.
4. Push the DISP button and the last 8 digits of your 12 digit Sirius Tuner ID Number (ESN) will be displayed.
5. Push the TUNE button to exit.

Selecting Sirius: Push the MODE button until “SIRIUS” appears in the display. Please be patient as it may take a minute to receive a satellite signal.

Manual Tuning:

1. Push the TUNE button until “NORMAL” appears in the display.
2. Rotate the TUNE knob to select a station from 01-182.

Category Tuning:

1. Push the TUNE button until “CATEGORY” appears in the display.
2. Push button 1 or 2 to find the desired category.
3. Rotate the TUNE knob and select a station.

Direct Tuning:

1. Push the TUNE knob until “DIRECT” appears in the display.
2. Rotate the TUNE knob and select the first digit (0 or 1).
3. Push the TUNE knob again.

4. Rotate the TUNE knob and select the second digit (1-8).
5. Push the TUNE knob again.
6. Rotate the TUNE knob and select the third digit (1-9). The tuner will start playing the station you have selected when the third digit stops flashing.

Note: Satellite radio signal may be blocked by trees, buildings, bridges, or tunnels.

To operate the AM/FM/Weather Band, push BAND button to select F1, F2, F3, AM1, AM2, or W (weather band).

Manual Tuning:

1. Rotate the TUNE knob left or right and hold until “MANUAL” appears in the display then release knob.
2. Rotate the TUNE knob again left or right until the desired radio station appears in the display.

Scan Tuning:

1. Push the TUNE knob to scan every 5 seconds for a different radio station. To stop scanning push the TUNE knob again.

Seek Tuning:

1. Rotate the TUNE knob left or right then release to seek for a different radio station.

Weather Band: Push the W-BND button for instant weather band operation.

NOTE: Push the MODE button to return to playback of other sources.

Programming AM/FM Stations: Select a radio station then select a button 1, 2, 3, 4, or 5 and push and hold until it beeps. The radio station is now programmed to that button.

Recalling Programmed Radio Stations: Push button 1, 2, 3, 4, or 5 to recall a pre-programmed station.

Clock Settings

Display Button: Push and hold the DISP button until the clock is flashing in the display.

Adjusting the Minutes: Rotate the TUNE knob to the Left to adjust the Minutes.

Adjusting the Hours: Rotate the TUNE knob to the Right to adjust the Hours. Note the AM/PM indicator.

NOTE: When correct time displays wait a few seconds to allow the time to program.

CD Operation:

Playing a CD: Insert a CD (label side up) into the CD slot. The CD will auto-load and start playing.

NOTE: If a CD does not auto-load, DO NOT FORCE into the slot, as you may already have a CD loaded.

CD Track Selection: Rotate the TUNE knob left or right to change the track.

Ejecting a CD: Push the EJECT button to eject a disc.

Pausing a CD: Push the MUTE button to “Pause” disc, press again to resume play.

CD Changer (optional):

Load CDs: Insert the CD magazine into the external CD changer.

Selecting the External CD Changer: Push the MODE button until “CDC” appears in the display.

CD Selection: Push button 1 or 2 to scroll through the selection of CDs in the CD changer. If a CD is not in one of the trays, the unit will continue until the next CD is found.

CD Track Selection: Rotate the TUNE knob left or right to change the track.

Reset Button:

The radio panel or LCD display may fail to function normally due to the vehicle’s battery condition, and may require resetting the microprocessor if:

- The vehicle has been “jump started” from a dead battery condition.
- The vehicle battery becomes very low and is quick-charged.
- The vehicle battery is removed and replaced.

Should this condition occur, simply press and release the RESET button on the radio panel using the tip of a ball point pen. All station programming should remain, but you will have to reset the clock.

NOTE: Your radio has Sirius satellite radio capabilities but this does not mean it is ready for immediate use. As an option, your radio may be equipped with a preinstalled tuner that will allow you to receive satellite radio after contacting Sirius and purchasing a subscription. Activation of the tuner requires the Sirius identification control number located on the back of the Sirius Satellite Radio Tuner Box. If your motor home is equipped with the optional tuner box, you will find a green bar code label with the identification number (Figure 4-14) in the owner’s information package. Your motor home has a factory installed satellite antenna (standard) but it may not have the optional tuner box. If you wish to purchase the subscription but do not have the tuner box, you may purchase the tuner box from Sirius. All necessary cabling and antennas are preinstalled. If you have any questions concerning the Sirius satellite option, you may contact Sirius Customer Care direct at 1-888-539-7474.



Figure 4-14. Sirius Satellite Identification Label

Cable & Telephone Jack

The Allegro Bay contains an exterior cable jack and also a telephone hookup (Figure 4-15). This telephone connection permits the owner to access external



Figure 4-15. Cable & Telephone Jack

telephone services (e.g., RV parks) so that these services are available for use within the motor home proper. Within the motor home there are several telephone jacks (e.g., living room) for connecting telephone(s), as desired.

Water Heater

Warning

DO NOT APPLY 120 VAC POWER to or LIGHT the water heater until after the water heater is filled with water and the water lines and heater tank are purged of any trapped air. Failure to do so will damage the water heater and may cause additional damage to the motor home.

Before the water heater is to be used, first fill the fresh water system and purge the water lines to and from the water heater by opening all the hot-water faucets until water steadily flows from each one and no “spurting” or “hissing” sounds are further heard. The water heater holds 6 gallons of water and uses either the LP gas system or the 120-volt AC electrical system to operate the heater.

Proper and safe operation of the water heater requires that all safety information provided in the owner’s manual be read and understood before placing the water heater in service. Take the time to become familiar with this manual (provided in the Owner’s Information Package).

The water heater is designed for operation either with LP gas or 120-volt AC electricity. Both modes of operation are now presented.

LP Gas – Electronic Ignition Operation (6-Gallon Model)

1. Turn the remote switch to the “on” position.
2. If the remote-switch light stays “on” longer than 15 seconds, turn the remote switch to the “off” position and wait 5 minutes.
3. Repeat Step One.
4. **(For 6-Gallon Models only):** For complete shutdown and also before any servicing:
 - a. Turn the remote switch to the “off” position.
 - b. Remove the red wire from the left-hand terminal of the ECO switch (ECO to valve).
5. If the water heater fails to operate because of high water temperature, the heater will go into a lockout condition (indicator light “on”). When the water eventually cools, reset the system by turning the switch to the “off” position for at least 30 seconds, then turn the switch back “on.”

6. If a lockout condition persists, contact your authorized dealer.

120-Volt AC Electrical Operation

1. For electrical operation, use the power switch on the water heater; depending on the particular model, that switch may be located either at the front or at the rear of the water heater.
2. Completely fill the water heater with water and purge the hot-water lines of any trapped air.
3. Turn the power switch located on the water heater “on.” NOTE: Turning the power “on” to the water heater without having previously covered the water-heating element with water may quickly burn out the element and void the warranty.
4. After awhile, check the water heater for proper operation; the water temperature should be approximately 140°F (60°C).
5. If the manual-reset, high-temperature-limit switch should trip the circuit breaker; reset the switch by depressing the reset button--use a pencil or other non-metallic object to depress the reset button. If the high-temperature-limit switch should again trip the circuit breaker, contact an authorized service technician or an authorized dealer.
6. Both the electrical and gas operations of the water heater may be used simultaneously to reduce recovery time of heating water up to desired temperature.

For general maintenance of the water heater or specific information about select steps in operating the water heater, please refer to the owner’s manual for this appliance contained in the Owner’s Information Package.

Warning

DO NOT STORE any combustible or flammable substances near or adjacent to the water heater. Provide adequate space for ventilation and air circulation.

Water Heater Storage

If the motor home is to be stored during the winter months, the water heater should be drained to prevent damage caused by freezing water contained in the water heater. To drain the water heater, first turn “off” all electrical power, turn “off” the LP gas going to the water heater, then turn “off” the water pump. Open both the hot- and the cold-water faucets to drain the water lines and open the drain plug on the water heater to drain the entire system.

When re-activating the water heater after the motor home is taken out of storage, make sure that the entire water system, including the water heater, has been filled with water and the lines have been purged of any entrapped air before relighting the water heater. Failure to do so may allow the water-heating element to be

turned “on” before such is immersed in water; thereby, causing the premature failure of the heating element and voiding the warranty.

Pressure-Relief Valve

The relief valve for over-pressure and over-temperature conditions is located on the exterior of the water heater. This valve will operate if the water temperature reaches or exceeds 210°F or if the water pressure reaches or exceeds 150 psig. Since the water system in the motor home is a closed system when all water valves are shut, the water-heating cycle can raise the temperature (and, consequently, the pressure) of the water in the water heater; thereby realizing pressure increases approaching 150 psig.

Should this pressure be reached, the pressure-relief valve will begin “weeping,” that is, minor dripping or leakage from that valve until the pressure drops below 150 psig, at which time the pressure-relief valve will reseat itself and restrict the water flow. This is normal operation and should not be a cause for alarm. Do not obstruct or block the pressure-relief valve in any way, as this would keep the valve from functioning normally and protecting the hot water system.

CB Radio System Antenna Connection

The Allegro Bay comes equipped with an antenna and coaxial-cable connection (Figure 4-16) to enable the owner to install a Citizens Band (CB) radio of choice and operate it conveniently from the Allegro Bay. The coaxial-cable connection for the radio is found beneath the dashboard on the driver’s side.

Accordingly, with an owner-provided CB radio, that radio can be used to communicate with other travelers on the road. To use the one’s CB system of choice, simply follow the directions furnished with the CB radio. (Note: Channel 11 is considered an emergency channel and monitoring this channel may give one information about road conditions, accidents, and related matters potentially affecting the travels of the motor-home operator).

To talk with someone, simply press the “push-to-talk” switch and speak. To listen to any reply, release the “push-to-talk” switch and listen to the speaker. Remember that communications are “one-way,” not “two-way” simultaneously—one must talk, then allow some listening time for others to talk. Consequently, it’s better to make brief transmissions and allow others to comment; rather than making prolonged speeches and possibly not having anyone answer.



Figure 4-16. CB Antenna System

Observe the common courtesies (see the owner’s manual for more details) and acceptable speech. Several states have their Highway Patrols monitor the CB frequencies (check for exact channels for each state of interest) to learn about highway problems and emergencies. Be aware of these throughout one’s travels, in the event that they may be needed.

Rear-View Camera Monitor System

The rear-view monitoring system (Figure 4-17) is provided to aid the driver in backing and parking the motor home. A camera mounted on the rear of the vehicle feeds a televised view of the rear of the motor home to the monitor located in the front near the driver.

If the mode switch is in the “manual” mode, the monitor will be “on” when the ignition switch is turned “on.” If the mode switch is in the “automatic” mode, the monitor will display the picture from the rear-mounted camera only when the transmission is in “reverse” gear. To use this system effectively, please consult the owner’s manual for this system; this manual is in the Owner’s Information Package.



Figure 4-17. Rear-View Camera Monitoring System

Warning

Do not view TV or video programs while driving.

Cleaning and General Maintenance:

1. If your Allegro Bay has been parked in direct sunlight resulting in a considerable rise in temperature inside the motor home, allow the unit to cool off before operating.
2. When the casing becomes soiled, clean it with a soft cloth dampened with a mild detergent solution. Never use abrasive cleaners or chemical solvents, as they might damage the casing.

Basic Rear View Camera Operation:

1. Depress the **POWER** switch. The picture appears on the monitor. **POWER** indicator light up green. To turn off the picture, press it again to release. The monitor becomes standby condition. **POWER** indicator light up red.
2. Adjust the **VOLUME** control.
3. Adjust the picture contrast and brightness. The **DAY/NIGHT** selector switch should normally be kept in the **DAY** (released) position. When you view the picture at night or in a tunnel, etc., depress the switch to make the picture less bright (therefore in the **NIGHT** position). Thus, the picture will be easy to view even in a dark place.

When you set the gear level to the “R” position with the **POWER** switch released: The monitor is turned on and the picture from the camera connected to the CAMERA “A” connector appears irrespective of the **INPUT** knob setting.

Warning

Note on the power of the monitor: When you press the **POWER** switch to release, the monitor becomes standby condition. The power is not turned off until you set the ignition key to the OFF position.

Warning

About the Liquid Crystal Display (LCD) panel:

Do not press on the LCD panel on the monitor unit as doing so can distort the picture or cause a malfunction. The picture may become unclear, or the LCD panel may be damaged.

Clean the LCD panel with a slightly damp soft cloth. **DO NOT** use solvents such as benzene, thinner, commercially available cleaners or antistatic spray.

Warning

If your motor home is parked in a cold or hot place, the picture may not be immediately clear. The monitor is not damaged. The picture will become clear after the temperature in your motor home becomes normal.

Washer / Dryer (Optional)

If an optional washer/dryer (Figure 4-18) unit is installed in the Allegro Bay, this appliance is essentially operated as one would normally be used in the home environment. This appliance operates on 120-volt AC electricity, so power must be available either from an external power-line connection or from the onboard electrical generator.

For specific information regarding the use of the washer or the dryer, consult the owner's manuals found in the Owner's Information Package.



Figure 4-18. Optional Washer & Dryer

Carbon Monoxide/LP Gas Detector

To protect the driver and other occupants of the motor home, the Allegro Bay is equipped with a carbon monoxide/liquid propane gas detector (Figure 4-19). Carbon monoxide (CO) is a colorless, odorless, tasteless gas which, when breathed, bonds to the hemoglobin in the red blood cells and, thus, drastically reduces or blocks the transfer of oxygen from the lungs to the rest of the body. In sufficient concentrations, CO kills by asphyxiation. In lesser amounts, CO makes the victim groggy, lethargic, and unable to think clearly or quickly.



Figure 4-19. Carbon Monoxide/LP Gas Detector

CO is one of the products of combustion for many materials including petroleum-based products (e.g., gasoline, diesel fuel, propane, butane; among others). Since many of the appliances and the engines associated with the motor home produce CO in their normal operations, it is necessary to assure that CO levels do not rise to dangerous levels within the motor home. In sufficiently high concentrations, CO can kill in minutes.

Warning

Carbon monoxide gas—derived from products of combustion of gasoline, LP gas, and other petroleum-based products—is a deadly gas which can kill motor-home occupants, if allowed to accumulate in sufficient concentration. Assure that all engine operations are not restricted—tailpipes and exhaust ports should not be blocked or restricted in any way. Additionally, any accumulation of exhaust gases outside or underneath the vehicle should be avoided as such may enter the motor home through windows or vents—be careful how and where the motor home is parked to avoid such

conditions. Regularly monitor outside conditions to assure that all exhaust gases can readily be dissipated and kept out of the motor home.

The most susceptible people to CO poisoning are unborn babies, small children, pregnant women, senior citizens, and people with cardiovascular or respiratory problems. Consequently, it is prudent to check the CO monitor regularly for normal operation and to remain aware of the symptoms of CO poisoning which include dizziness, nausea, vomiting, muscular twitching, throbbing in the temples, incoherent thinking and speech, weakness, sleepiness, and intense headaches.

Warning

Never sleep in a motor home when the engine is running—engine exhaust fumes could enter the motor home and cause disability or death. Regularly check the exhaust system to note any leakage sites and, if found, discontinue use of the motor home until they are repaired by a competent, qualified service technician. Do not attempt repairs on the exhaust system yourself and do not modify (temporarily or permanently) the exhaust system at all.

Should any of these symptoms be experienced in the motor home, one should IMMEDIATELY evacuate the motor home and seek medical help. Shut down the motor home and do not attempt to operate it again until the source(s) of the CO are located and fixed.

The CO/LP gas detector digital readout will display carbon monoxide readings from 30 to 999 parts per million (PPM) of CO in the ambient atmosphere within the motor home. Under normal operating conditions in the motor home, the display reading should be zero. Besides taking CO readings every 30 seconds, the CO/LP gas detector also will indicate the status of the battery life with a LCD (liquid-crystal display) icon and the operating condition of the sensor on the digital display by means of a “beeping” sound and a flashing red light.

The motor-home owner should become quite familiar with these digital-display readings and check them regularly and frequently. The display will also indicate possible sensor malfunctions and low-battery-voltage conditions (i.e., flashing red light and “chirping” of alarm).

In the event of an alarm, the following steps should be taken quickly:

1. If the alarm signal sounds (4 beeps and flashing or solid red light), operate the Test/Mute button.
2. Immediately move to a source of fresh air, either outdoors or by and open door or window. Do a “head count” to make sure that all people (and pets!) within the motor home have moved to a source of fresh air, too. Do not reenter the motor home or move away from the source(s) of fresh air until the

emergency responders have arrived, the motor-home interior is sufficiently aired out, and the alarm has reverted to its normal monitoring function (i.e., no alarms).

3. Call the local emergency services (i.e., 911 in most locales) to summon help -- don't go back into motor home to make this call, but use a cell phone, if available, or have someone else nearby make this call.
4. Should the CO/LP gas detector alarm again activate within a 24-hour period, repeat Steps 1 through 3 and also call a qualified service technician to investigate the possible sources of CO (e.g., fuel-burning equipment and appliances) to locate, identify, and fix such.

Warning

Test the alarm's operation after each storage period, before each trip or at least once per week during use.

Cabinets & Furniture

Cabinets

Your Allegro Bay contains cabinetry (Figure 5-1) installed throughout the entire motor home from the driver's area, through the kitchen/dining areas, and back into the bedroom. The cabinetry has been designed and built to provide ample storage space and to be easily accessible and conveniently located to support the areas of concern.

Construction of these cabinets incorporates various hardwoods, raised panels, cabinet doors, and supports. Door pulls, handles, and knobs are installed in a style complementing the particular décor of each Allegro Bay so that an aesthetically pleasing, as well as fully functional, storage capacity is realized.

For the many floor plans available in the Allegro Bay product line, cabinet design has been optimized to provide maximal storage for each and every floor plan available. Accordingly, the Allegro Bay can readily accommodate the routine materials, supplies, and customer-specific items desired for any travel requirements.



Figure 5-1. Representative Cabinetry in the Motor Home

Further, these cabinets are designed to contain stored supplies quite securely during travel to minimize or eliminate the possibility of shifting or spilling of cabinet contents during travel. Yet, when the motor home is parked, all stored items are readily available in the cabinets for the convenience of the users.

As the storage requirements will vary somewhat from one floor plan to another, general observations can be made about the Tiffin-supplied cabinetry which may or may not be applicable for your specific Allegro Bay configuration.



Figure 5-2. Countertop

Cabinets are provided in the kitchen/dining area to accommodate the routine cooking utensils and groceries normally desired for travel. Storage space within these cabinets has been so designed to accommodate the typical sizes and configurations of food supplies (e.g., cereal boxes, condiments, canned goods, bottled liquids) normally taken on travel trips.

Based on Tiffin Motorhomes' extensive experience with travel requirements of the seasoned motor-home users and from Tiffin Motorhomes' own research and development in contemporary cabinet-design requirements, the resultant cabinets offer the greatest storage capacity possible.

In the bathroom and bedroom, additional cabinets are available for storage of sundries and toiletries specific to these areas.

In the kitchen, a color-coordinated countertop (Figure 5-2) is provided on top of the floor-mounted cabinets. To maintain the appearance of the countertop, clean with a damp cloth. If spotting occurs, clean the countertop with a damp cloth and a mild liquid soap. Should some dried-on residue still persist, let a damp cloth moistened with the liquid cleaner stand directly on top of that residue for 15-30 minutes to loosen the residue, then clean that spot accordingly. Please note that strong chemicals, solvents, and cleaners (e.g., oven cleaner) may damage the surface; so do not use any products not specifically designed for countertop cleaning.

The countertop may be physically damaged, too, if proper care is not taken. Do not cut anything (e.g., vegetables, fruits) directly on the countertop; rather, use a cutting board on top of the countertop to provide necessary protection to the countertop. Excessive heat may also damage the countertop; therefore, any pots or pans taken directly from the range or oven should not be placed directly on the countertop; rather, use trivets or some other form of fireproof heat insulators to hold very hot pots or pans on the countertop.

All drawers are equipped with metal slides to provide additional load-bearing strength for the drawers and to permit effortless opening and closing of those drawers, even when they are fully loaded. These metal guides have a slight “locking” action, when closed. To open those drawers, slightly lift up on the drawer handle and then pull the drawer open. To close, push the drawer closed until it “clicks” back into place (i.e., the locking action is engaged).

As this cabinetry is typically of furniture-grade quality, any commercial furniture polish or cleaner can be used. Do not try to soak these wooden surfaces with any water or any other liquid; be sure to wipe up spills or residues of any fluids that contact these surfaces to preclude any staining or discoloration of the cabinet surfaces.

Furniture

Kitchen, Dining, & Living Room Areas

On all the various floor plans of the Allegro Bay, either a built-in dinette booth (Figures 5-3,4) or a free-standing table (Figure 5-6) is provided. This dinette provides additional storage under the seat area of the booth, in addition to providing additional sleeping facilities. The sleeping area is realized by lowering the dinette-table top and rearranging the seating cushions. Specific directions for converting the booth dinette into a bed are as follows:

1. Remove the seat cushions.
2. Remove the wooden fill blocks.
3. Fold the table leg upwards while slightly lifting the table, then allow the table to swing down and rest between the two booth seats; thus, forming the bed.
4. A “filler strip” (Figure 5-5) is attached to the seat portion (via a long Velcro strip) of the sofa. Simply pull these two pieces apart. The filler strip can be conveniently stored



Figure 5-3. Dinette Booth Table



Figure 5-4. Dinette Booth Table Converted into Bed

underneath the dinette until you are ready to re-convert the bed back into a sofa.

5. Re-install the seat cushions and back rests to make up the mattress for the bed.

The living room contains a standard sofa (Figure 5-7) which can be converted into a full bed for sleeping, as required. The sofa is custom coordinated with the décor of the motor home. To convert



Figure 5-5. Filler Strip Attached to the Seat Portion



Figure 5-6. Dining Table & Chairs

the sofa into a bed, follow these directions:

1. Remove the accent pillows.
2. Under a seat cushion locate the “black tab” and slide the tab to the left or the right and then pull upwards on the seat portion of the sofa—this will cause the sofa seat to open, extend, and convert into a bed.



Figure 5-7. Sofa

There may also be a swivel rocker with an adjustable headrest or a recliner, also coordinated with the décor of the motor home. For the driver’s seat an optional power seat is available which offers an electric-powered, six-way power seat (i.e., movement: up, down, forward tilt, reverse tilt) having swivel features (and recline features for the passenger seat only).

When the motor home is parked, the driver’s seat (Figure 5-8) can be swiveled to face into the living room. To swivel this chair, first extend the slide-out room (see Chapter 8 for additional detail). Then move the chair backwards as far as possible to gain clearance from the steering wheel. Now the chair can be swiveled without interference.



Figure 5-8. Captain's Chair

The control switch for the driver’s chair is located on the left-hand side in front of the power base controls. In a comparable manner, an optional power seat is also available for the passenger’s seat which also includes the electric-powered, six-way seat having essentially the same controls as that of the driver’s seat and it is operated accordingly.

Bedroom Area

If a décor-coordinated, quilted bedspread with accessorized pillow shams and accent pillow(s) are included with the bedroom suite, it is recommended that the bedspread be dry-cleaned only to preserve the quality and integrity of the bedspread for the longest time possible.

Treatment of the bedspread with any of the stain-resistant sprays (e.g., Scotchgard or its equivalent) will also make the bedspread more resistant to the possibilities of stains and fabric damage.

If maintained properly, the bedroom soft-goods accessories will provide years of dependable service and maintain the desired décor established by the motor-home owner.



Figure 5-9. Typical Bedroom Area

Select Comfort Mattress (Optional)

Your Allegro Bay may be equipped with an optional Sleep Number Bed by Select Comfort. A remote control (Figure 5-10) accompanies the bed so that one may control the firmness of his/her bed.

To select your personal Sleep Number, follow these steps:

1. Lie on the Sleep Number Bed in your normal sleep position, holding your remote.
2. Press and release any button on the remote to “wake” it up. It will display the current SLEEP NUMBER setting. **Note:** To activate the controller, your motor home must be connected to shore power or the generator must be running. This is to allow the air pump to operate. If you have an idea of what your Sleep Number is, enter it on the remote by pressing the firmer or softer buttons until the number you desire is displayed. Remain still until the change is complete. When adjustment is complete, the Sleep Number will stay lit for five (5) seconds and then the display will turn off.



Figure 5-10. Select Comfort Mattress Remote Control

If you decide to change your Sleep Number before the firmness adjustment is complete, just press any button and the Firmness Control System will stop adjusting. Then, go to the Sleep Number you want.

If you don't already have your Sleep Number or would like to experiment with finding a different one, follow the directions below:

1. Lie down on your Sleep Number Bed in your normal sleep position holding your remote.
2. Press and release any button to get the current Sleep Number setting. Set the Sleep Number to “50” on the remote.

3. Take time to evaluate your comfort.
4. If you like the feel of the mattress at “50,” go to step 5. If you find that this setting is too firm or too soft, change your Sleep Number in increments of 5. Reevaluate your comfort level after each change. Once you have found a Sleep Number setting where you feel comfortable, log this number into your Sleep Journal.
5. Try to sleep at this Sleep Number for a minimum of five nights. It will take your body that long to become accustomed to a new sleep surface. After five nights, reevaluate your comfort level and log this into your Sleep Journal. If you need to make adjustments, repeat steps 4 and 5.

If after trying four different Sleep Number settings you have not found your ideal Sleep Number, please call Select Comfort’s Customer Service at 1-800-318-2231. A trained representative may be able to recommend adjustments, make suggestions, or pinpoint concerns that might be contributing to less than ideal comfort.

The cover of your Sleep Number mattress may be spot cleaned with carbonated water or mild detergent. DO NOT dry clean the mattress cover or put it in a washing machine. Also, please DO NOT apply stainguard, as it may cause yellowing of the fabric.

Select Comfort is a leader in the industry in the use of materials designed to inhibit the growth of allergens or microorganisms that, in rare circumstances, can form inside any mattress, bedding, pillow or upholstered product.

Advance antimicrobial safeguards are incorporated into every Sleep Number bed. Key components of the mattress have been treated to protect the bed from contaminants such as mold, mildew and bacteria growth. The unique, zip-open design of the Sleep Number bed allows you to easily open and view the inside of your bed, and ventilate or vacuum, if you choose.

In rare instances under the right conditions, mold or mildew can form inside many types of mattresses, bedding or upholstered products. Should this condition occur in your mattress, please contact Select Comfort’s Customer Service so they can work with you to return your bed to factory fresh condition. If you have particular sensitivities to dust mites, mold or mildew, you should exercise care to minimize any direct exposure to these allergens.

Warning

Note before traveling: If you plan to travel with your SLEEP NUMBER mattress into mountainous regions, either (1) temporarily disconnect the mattress from the pump hose to allow air to escape or (2) partially deflate the mattress chamber to a Sleep Number of “20.” Rapid changes in altitude will affect the air pressure inside the mattress. The chamber may be damaged if the pressure becomes too great.

CABINETS & FURNITURE

Structural Features

Chassis Features

The chassis (Figure 6-1) of your Tiffin Motorhomes Allegro Bay was built and is warranted by Ford, Freightliner, or Workhorse, the chassis manufacturers. The operating instructions for the specific chassis are included in the Chassis Owner's Manual which is provided with your Allegro Bay and is a part of the Owner's Information Package furnished to you by your Tiffin Motorhomes Dealership.



Figure 6-1. Typical Motor Home Chassis

Before you begin using your Allegro Bay, please read and follow all recommendations for the proper care, operation, and maintenance of the chassis—this will assure you of pleasant, trouble-free use of your motor home. Should you have any questions about the chassis, however, you should contact your chassis manufacturer as noted in the literature described earlier.

TYPICAL CHASSIS ITEMS COVERED UNDER WARRANTY BY THE CHASSIS MANUFACTURER	
	Steering Wheel
	Steering System
	Instrument Panel
	Engine
	Transmission
	Chassis Frame
	Axles
	Fuel Tank
	Suspension and Springs (Front-End Alignment is not covered)
	Tires and Wheels
	Brakes
	Exhaust System
	Leaf Springs

Alignment

The Allegro Bay motor home you have purchased has been aligned at the factory prior to shipment to you. During the first 10,000 miles of operation of your Allegro Bay, the chassis will have a tendency to “settle” and readjust itself in response to the loading of your motor home. Although it normally is not necessary to realign the Allegro Bay before the first 10,000 miles of use; it is, nonetheless, recommended that you have the Allegro Bay alignment checked after the first loading of the motor home.

However, if you feel that you have noted some discrepancy or anomaly in steering operation, please contact your chassis manufacturer or call Tiffin Customer Service at (256) 356-0261 to address your concerns.

Electrical Features

General Information

There are two electrical systems in your Allegro Bay motor home—these are the 12-volt DC (VDC) system and the 120-volt AC (VAC) system. Most standard appliances require the 120-VAC system, while the majority of the lighting systems used in the Allegro Bay use the 12-VDC system. The electrical power for the 12 VDC system is supplied by the batteries of the Allegro Bay; those batteries are, in turn, charged by a power converter. The electrical power for the 120 VAC is supplied by the electrical power hookup cord when the Allegro Bay is connected to an external power source or when the on-board electrical generator is in operation.

Caution

Failure to turn off the 120 VAC appliances when starting or stopping the generator may damage the transfer switch and/or electrical appliances.

To connect the Allegro Bay to an external source of 120 VAC electrical power, it is first recommended that all of the circuit breakers are in the “off” position—this is done to prevent any power surge upon connecting the motor home to the external power source. Then unwind the power cord from the electrical compartment located in the compartment behind the driver’s-side rear tires. The standard, flexible, power cord supplied with the Allegro Bay is designed to handle up to 50 amperes. Make sure that the pins in the male end of the plug are oriented correctly so that they match the power cable, and that they are in good condition (i.e., aren’t bent or damaged). If there is a circuit breaker switch at the “plug” end of the power cord, that breaker should be turned “off” before making the connection. Insert the plug into the mating outlet and then turn the circuit breaker “on.” Close and lock the electrical compartment door to protect the contents and to keep them clean and dry. Close the cover on the power box, if so equipped, to avoid an unintentional disconnection and to keep the contents clean and dry. Then switch the main breaker to the “on” position. When properly connected, the 120 VAC system provides power to all the 120 VAC circuits and outlets when the main breaker is turned “on.”

Circuit-Breaker Boxes

For the Allegro Bay, the 120 VAC and 12 VDC breaker boxes (Figure 7-1) are typically located beneath the refrigerator or in the bedroom [*if inside the vehicle*] or in the storage box [*if outside the vehicle*]. The circuit breakers and associated fuses are installed to protect the electrical system of the Allegro Bay from any overloads. Do not attempt to change the electrical circuitry or to add appliances yourself. Please consult an authorized Tiffin Motorhomes Dealership or Tiffin Motorhomes, Incorporated in Red Bay, AL to determine whether any changes you desire are appropriate and acceptable. Tiffin Motorhomes’ qualified staff of electricians can readily determine whether any changes sought (e.g., CB radio, amateur radio, satellite television receiver, personal



Figure 7-1. Circuit-Breaker Box

computer system, and the like) are possible or not and can advise you on how best to realize these enhancements. Please note that the 12VDC fuses and breakers are located in a separate compartment adjoining the 120 VAC breakers. Fusing is provided for the following 12 VDC circuits: All interior and decorative and overhead lighting, water heater, TV switching box, slideouts, power roof vents, monitor panel, and 12 VDC disconnect panel.

Auxiliary Start Switch

The auxiliary start or emergency start switch (Figure 7-2), located on the left side of the dashboard (Figure 7-3),



Figure 7-2. Auxiliary (Emergency) Start Switch

briefly connects the Allegro Bay coach batteries to the chassis batteries which, in turn, allows the chassis batteries to “borrow”

power from the coach batteries to assist in starting the engine. If

the chassis batteries cannot themselves start the engine in the “normal” mode, hold down the battery-boost switch and retry starting the engine. By using the battery-boost switch while trying to start the Allegro Bay engine, a jump-start situation is realized between the coach and chassis batteries. If the battery-boost switch is required to start the engine on a regular basis, have your Tiffin Motorhomes Dealership check the chassis batteries and the associated charging system.



Figure 7-3. Driver's Side Dashboard and Instrumentation Console

Battery Inspection and Care

As the batteries contain a significant, and potentially lethal, amount of electrical energy; they must be handled with due diligence and care. Some of the routine precautions include:

Warning

Remove rings, metal watchbands, and any other metal jewelry before working around batteries. If any metallic object (tool, jewelry, etc.) contacts the positive battery terminal or any connection made to that terminal AND also contacts the negative terminal or any of its connections, a SEVERE ELECTRICAL SHORT will occur which could result in an explosion, fire, and/or personal injury. Lead-acid batteries contain diluted sulfuric acid which can be dangerous; avoid direct contact with any battery fluids. Always wear eye protection while servicing batteries.

Caution

Disconnect the 120 VAC electrical power cord and the negative terminal from the coach batteries BEFORE working on the Allegro Bay electrical system.

Caution

If the Allegro Bay ever requires any welding operations on the frame, first disconnect the chassis batteries. Failure to do so will destroy all of the chassis computer system.

When batteries are not used for extended periods of time, they will gradually lose their electrical charge. Therefore, it is necessary periodically to recharge the batteries to increase the operational lives of the batteries. It is also necessary to check the external condition of the batteries on a regular basis. Look for cracks in the battery case and cover. Check the vent plugs and replace them if they are cracked or broken. Keep the battery clean.

Since accumulations of dirt and acid residue around the battery terminals may provide an electrical path for discharging the battery, the area around the terminals should be cleaned periodically. One can use an old toothbrush and a sparse amount of a diluted solution of baking soda (sodium bicarbonate) and water (distilled or de-ionized, preferred; tap water, acceptable) to clean and neutralize any acidic build-up around the battery terminals.

If there is any foaming on the top of the battery, this indicates that acidic residues are being neutralized. Rinse the cleaned areas thoroughly with distilled or de-ionized water (tap water is okay, too). Avoid getting the baking-soda solution into the battery fill plugs to each battery cell; this would drastically reduce the effectiveness of the battery (by neutralizing the sulfuric acid in the battery cells) or, worse, “kill” the battery. Dry the battery cables and terminals to prevent corrosion; to protect those terminals further, use a plastic ignition spray on the terminals.

Do not use grease on the terminals, especially on the metal-to-metal connections, as grease may act as an insulator and keep the battery electrical power from entering the cables.

If the batteries are not going to be used for an extended period of time, they should be removed from the Allegro Bay and stored in a warm, dry place. IT IS STRONGLY RECOMMENDED that this service be performed by a qualified service technician, as the process is usually too complicated for the average owner to perform. For those who may wish to perform this service themselves, the following procedure is described: Mark the battery cables (“+” sign or “red” for the positive cable; “-” sign or “black” for the negative cable) so that they can be properly reconnected again later. Then disconnect the negative terminal(s) from the batteries. Afterwards, disconnect the positive terminals. Now the batteries can be removed for storage. When the

batteries are moved, keep them upright at all times. To reinstall the batteries at a later date, reverse the above-described process. While in storage, these batteries would require periodic recharging to maintain their full charge.

Additionally, the batteries will, over time, lose some of the water used with the sulfuric acid in the batteries. Following manufacturer's recommendations as found in the Owner's Information Package, periodically check the fluid levels in all the cells of the batteries (be sure to use safety eyewear during this process) and fill those that are low with water (distilled or de-ionized water is preferred; tap water is okay). Don't overfill the cells; follow the filling directions exactly. This battery checkup should be done on a regular basis to realize the fullest service possible from the batteries over the longest time possible.

If the Allegro Bay is to be stored for an extended period of time, the 12 VDC battery system should be disconnected—this will prevent unnecessary drain and corrosion of the batteries and their terminals.

Battery Disconnect Panel

The battery disconnect panel (Figure 7-4) is located near the interior step. There is a rocker switch on the lower left-hand side of the panel which can disconnect the battery when the motor home is to be stored for any appreciable time. Pressing this switch downwards disconnects the coach batteries only, not the chassis batteries. This feature is designed to prevent the coach batteries from being drained during extended storage.



Figure 7-4. Battery Disconnect Panel

This switch also disconnects all the 12 VDC circuitry from the batteries; thus removing the total electrical load from those batteries, with the exception of the LP detector. When the Allegro Bay is removed from storage, press the switch upwards to reconnect the 12 VDC circuitry to the coach batteries again and the 12 VDC systems are now reactivated.

upwards to reconnect the 12 VDC circuitry to the coach batteries again and the 12 VDC systems are now reactivated.

120-Volt AC (VAC) Receptacles

Your Allegro Bay Motor Home is equipped with several 120 VAC receptacles (Figure 7-5) located throughout the interior of the motor home. These 120 VAC receptacles are of the “three-prong” variety; the third prong being a grounding pin which provides adequate grounding to protect one from any electrical shock.

For these receptacles to work properly, do not use an adapter, cheater, or extension cord which defeats the function of the grounding pin. For the same reason, never remove or bend away the ground prong or pin from any three-prong AC plug so that it would fit a two-prong AC receptacle (i.e., an ungrounded AC receptacle).



Figure 7-5. 120 VAC Receptacle

Never operate the Allegro Bay if there is an electrical short present, as an electrical short may deliver an electrical shock to anyone coming in contact with the exterior of the unit. If you should feel even the slightest of electrical shock, immediately disconnect the unit from the 120 VAC power source and locate the electrical fault (i.e.,

typically, it is a break in the grounding circuit).

Do not reconnect the 120 VAC power until after that electrical fault is fixed—the grounding circuit must be continuous from the frame to the distribution panel, to the power cord, and to the earth ground so that electrical-shock protection is realized.

12-Volt DC (VDC) Receptacles

Your Allegro Bay Motor Home is equipped with a 12 VDC receptacle (Figure 7-6) conveniently located on the dashboard or bulkhead (i.e., the round connector with a captive, black cover as shown in the figure).

This 12 VDC receptacle can be used for providing power to various items, such as cellular phones or personal computers or portable communications equipment. This receptacle is usually found on the bulkhead in front of the passenger's seat so that it is conveniently available to be used by the personnel in the cockpit area



Figure 7-6.
12VDC
Receptacle

Ground-Fault-Circuit-Interrupt (GFCI) Receptacles

In the kitchen and bath areas, there are 120 VAC GFCI receptacles (Figure 7-7) which provide greater protection against inadvertent electrical shocks. These specialized GFCI receptacles provide both overload and short-circuit protection for the user. The electrical receptacles located in the slide-out(s) are wired through the kitchen GFCI.



Figure 7-7. GFCI
Receptacle

The exterior receptacles are wired through the bathroom GFCI. Consequently, if an appliance plugged into a slide-out or exterior receptacle is not working, check for a tripped GFCI in the kitchen or bathroom.

In addition, these receptacles protect the user from ground faults between an electrically “hot” wire and ground. The GFCI will not reduce the shock hazard if the short is between a neutral and “hot” wire, or two “hot-load” wires.

The GFCI should be tested at least once a month. The 120 VAC electrical system must be “on” for the GFCI to be tested.

To test the GFCI the reset button needs to be pushed “in” fully before starting the test. Push the test button; this will cause the reset button to pop out which means that the protected circuits have been disconnected. Push the reset button back in until a “click” is heard—this will re-activate the protected circuit. If the GFCI is working properly, the reset button will remain in the “in” position.

Electrical Generator

The electrical generator (Figure 7-8) can be found in an outside storage compartment underneath the motor home. The



Figure 7-8. Electrical Generator

generator is conveniently located on the passenger's side of the Allegro Bay and is easily accessible.

Prior to starting or stopping the generator, make sure that all the 120 VAC appliances are turned “off.” After the generator has been started, wait until the transfer switch has connected before turning “on” any of the appliances.

The generator can be started from either the remote-start switch located on the dash or directly at the generator itself. The hour meter installed on the generator records the number of hours of operation of the generator motor—this elapsed time is needed for observing necessary maintenance schedules on the generator.

Caution

Failure to turn “off” the 120 VAC appliances when starting or stopping the generator may damage the transfer switch and/or electrical appliances.

For more detailed operating instructions of the generator and to determine necessary preventive-maintenance schedules and procedures, review the manufacturer owner's manual.

Inverter / Converter

When the 120 VAC power is not available, either from the power cord or the generator, the optional inverter/converter (Figure 7-9) may be used (if such is installed in the Allegro Bay). The control panel for the inverter/converter is located above or near the entrance door.



Figure 7-9. Inverter/Converter (Optional)

When the inverter/converter is turned “on,” it transforms the 12 VDC power to 120 VAC power for the operation of lights, appliances, televisions, and related items. The 120 VAC power which is generated by the inverter/converter is routed to the electrical sub-panel located next to the main breaker box under the refrigerator [*if inside the vehicle*] or in the storage compartment [*if outside the vehicle*].

For proper operation of the inverter, one should initially set the inverter functions (Figure 7-10), as follows:

- **Setup Mode** -- Enter the Setup Mode by pressing and holding the “Setup” pushbutton switch for 5 seconds until the LED (light-emitting diode) blinks. For the 458 Series, the Freedom Remote is connected if at least one DC Volts LED is “on.” After 5 seconds of no activity, the Freedom

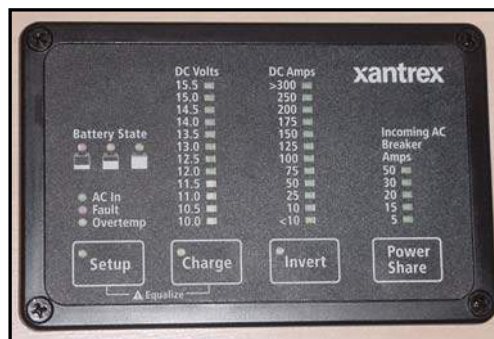

Figure 7-10. Inverter Control Panel

Remote automatically exits from the Setup Mode.

In the following additional steps, the most critical setup settings are the “Battery Type” and “Battery Capacity,” so use care to adjust these properly.

- **Charge [Battery Capacity (Ampere-hours)]** – For the Charge function, set the Ampere-hours rating of the battery bank by pressing the “Charge” pushbutton switch to 400 Ampere-hours.
- **Invert [Idle Load (Watts)]** – For the Invert function, select the idle setting by pressing the “Invert” pushbutton switch. If present inverter loads are less than the selected value, the inverter will remain in the Idle Mode. Idle Mode operation prevents unnecessary power drain on the battery system when no AC loads are in use. When an AC load is turned “on,” and the load wattage exceeds the idle value, the unit begins full-power inverting. When the appliance is turned “off,” the inverter then returns automatically to the Idle Mode. A setting of “zero” disables the Idle Mode. Set the Idle Mode to “zero.”
- **Power Share [Power Share (Battery Type)]** – To select the battery type, push the “Power Share” pushbutton switch to select the “wet” option.

The breakers in the sub-panel are labeled to explain where the 120 VAC power is routed. Generally, the inverter/converter supplies power to the microwave, kitchen, bath, and bedroom receptacles and other, select receptacles. The inverter/converter is equipped with an automatic transfer switch which allows automatic switching from inverter to converter.

When the Allegro Bay is connected to an external power source or the generator is being used to supply power, the converter will automatically switch “on” to charge the 12 VDC batteries. For more detailed information, consult the manufacturer owner’s manual located in the Owner’s Information Package.

Automatic Transfer Switch

Your Allegro Bay is equipped with an automatic transfer switch. When the generator is turned “on,” this switch automatically transfers from external power to generator power. There will be a slight delay between the start of the generator and the electrical connection being made—this delay allows the generator to reach normal operating speed without needing to supply a required load. When the Allegro Bay is plugged into an external source, a “click” will be heard in the transfer switch box—this is a normal function and merely indicates that the unit is changing over from an external power source to the generator.

Resettable Circuit Breakers

The resettable circuit breakers (Figure 7-11) are located in the external storage compartment just forward of the entrance door. When the circuit breakers are shut down or electrically tripped, they must be manually reset.

These breakers protect the slide-outs, the AC ignition, the electric step, the 30-amp ignition system, and the 12 VDC disconnect

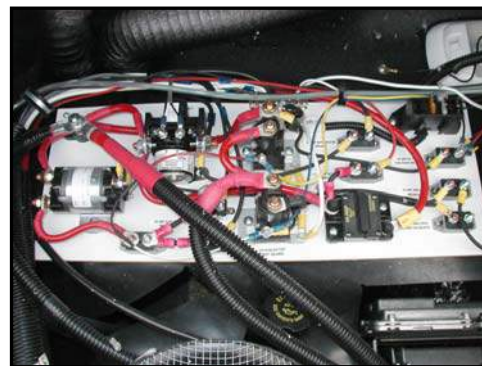

Figure 7-11. Circuit Breakers

Warning

Never replace a fuse with a fuse rated larger than that which originally came from the factory. To do otherwise will cause serious damage, overheating of the wiring, and possible ignition of nearby materials resulting in a fire.

Seven-Pin Towing Connector

Your Allegro Bay is equipped with a standard, 7-pin connector (Figure 7-14) near the towing hitch at the rear of the motor home to supply the necessary circuitry to control a towed vehicle. The wiring of that connector is shown in the accompanying diagram.

Make sure that any cable from the vehicle to be towed is wired correctly to mate properly with the connections shown in the connector. If in doubt about proper wiring, have a qualified service technician prepare and install the necessary cable to mate with the 7-pin connector on the motor home to assure proper operation subsequently when any vehicle is actually towed by the motor home.

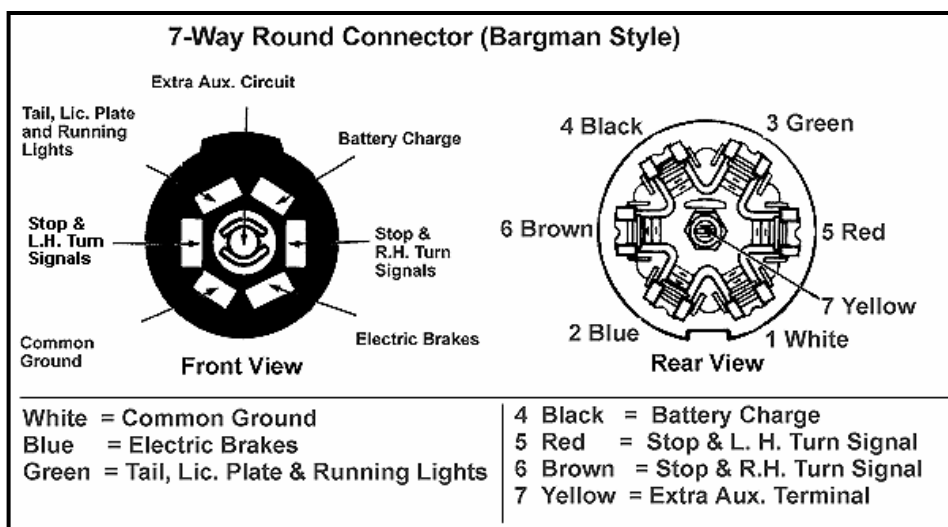

Figure 7-14. Seven-Pin Towing Connector

When the towed vehicle is uncoupled from the motor home and the cable is disconnected from the 7-pin connector, be sure to close the spring-hinged cover plate on the connector to protect the contact pins from dirt or debris. In a similar manner, protect the cable end from similar damage, weather, or debris—one such method could be to place the connector end in a heavy-gauge plastic bag (e.g., polypropylene, polyethylene, etc.) and secure the bag tightly around the cable with a stout elastic band or tape and then mount the secured cable in a manner to keep it both from mechanical damage and water intrusion.

When the towed vehicle is again coupled to the motor home via the towing hitch and the cable is again connected to the 7-pin connector, make sure the resultant connection is tight and solid so that the connection won't jar loose during use. Several supplemental methods to secure that connection have been used; some of which include securing the connection with a strong rubber band or with Velcro-type fasteners to provide a supplemental mechanical backup to the actual electromechanical connection.

ELECTRICAL FEATURES

Should a conversion adapter to convert the round, seven-pin connector to a flat, four-pin connector be needed; such an adapter may be purchased from any RV after-market store.

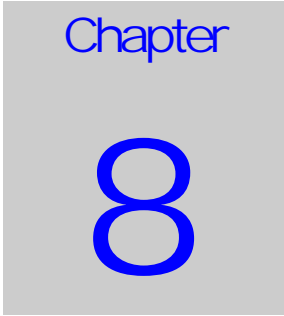

Slide-Out Features

SLIDE-OUT OVERVIEW

Warning

BEFORE ACTIVATING THE SLIDE-OUT FEATURES, please read the slide-out room instruction manual first. Additionally, the motor home must be parked and the leveling jacks must be used to level the motor home PRIOR to activating the slide-out features.

General Considerations

Please Note

The Slide-Out Room requires semi-annual inspection (i.e., every six months) to assure that the slide-out mechanism is properly aligned and functioning correctly. Please make sure that this inspection is performed every six months to correct any possible misalignments.

The slide-out-room feature is actuated by means of a readily accessible, rocker switch (Figure 8-1). The rocker switch must be manually held down in the desired position (i.e., either “in” or “out”) to activate the desired action of the slide-out room and continue to be held down until the desired action is concluded.

NOTE: The rocker switch for the slide-out will only operate when the ignition switch is in the “off” position—there is an interlock which keeps the slide-out mechanism from operating when the ignition is “on.” Releasing the rocker switch before the slide-out is fully extended or retracted will stop the slide-out at some intermediate position. NOTE: The 30-Ampere circuit breakers for the slide-outs are mounted on the firewall of the motor home. Should they need to be re-set, one must go to the firewall to do so.

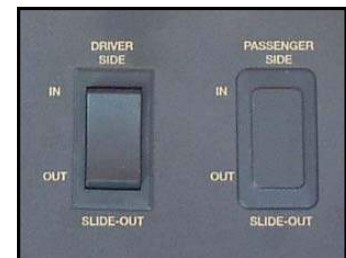

Figure 8-1. Slide-Out Switches

Operating Precautions

Before the slide-out-room mechanism is to be used, make sure that the motor home is parked and the leveling process has been properly completed. Verify that no obstacles (e.g., branches, trees, telephone poles,

power/water hookups, trash bins, and the like) are within a five-foot space envelope of the slide-out room to preclude damaging the slide-out room when it is finally deployed.

Warning

Before attempting any extension of the slide-out room, check outside and make sure that there is at least a five-foot clearance around the area where the slide-out room will be extended.

Extending the Slide-Out Room

1. All windows in any slide-out room must be closed and secured before that slide-out room is to be extended or retracted. Also any loose materials or possible obstructions should be removed from the immediate slide-out room area. Make sure the motor home has been leveled. Make sure that the battery is fully charged and connected to the electrical system.
2. Verify that there are no obstructions outside which may interfere with the operation of the slide-out room.
3. Prior to moving the front slide-out room in either direction, make sure that the driver's chair is moved forward into the driving area as far as possible and is locked into position.
4. Make sure that the ignition switch is in the "off" position prior to using the slide-out function; if the ignition switch is "on," the slide-out mechanism won't work.
5. Push the "out" portion of the rocker switch; allow the slide-out room to go to its fully extended position—at this point, release the rocker switch (this locks the room into position).

Retracting the Slide-Out Room

1. Before attempting to move the motor home, any slide-out room(s) must be fully retracted.
2. Verify that the battery is fully charged and connected to the electrical system.
3. With the ignition switch in the "off" position, push the "in" portion of the rocker switch; allow the slide-out room to go to its fully-retracted position—at this point, release the rocker switch (this locks the room into position).

Manual Operation: Slide-Out Room

Your Power Gear slide-out system is equipped with a manual override that allows one to extend or retract the room in the event of a loss of power.

Please Note

If the slide-out room doesn't move when the rocker switch is depressed, check the following:

Make sure the ignition switch is turned "off."

Make sure the battery is fully charged and connected.

Make sure the slide-out breakers haven't been "tripped"—these breakers are located on the firewall.

After the previous items have been checked and the slide-out room still does not move when the rocker switch is pressed, follow these simple steps (Figure 8-2) to override the slide-out room manually.

1. Turn "off" the ignition switch.
2. Locate the slide-out electrical controller (refer to your Tiffin Motorhomes dealer or the Tiffin Motorhomes factory for its location). There are two versions of the controller. For version 1, unplug the six-pin wiring harness to the controller. For version 2, remove one of the motor leads (either the motor I or the motor II lead from the controller).
3. Locate the slide-out motor; it will be mounted to one side of the slide-out rails. NOTE: If the motor home has an underbelly or a cover over the motor, these parts must be removed to access the motor.
4. Rotate the brake lever, on the backside of the motor, counter-clockwise (CCW) (looking from the rear of the motor) about 1/8 of a turn to the released position. This action will release the brake that holds the room in place.
5. Locate the manual override for the slide-out system.
6. The room is now free to move. Using a 3/4" wrench or socket, crank the room either "in" or "out" completely (depending on your needs).

Figure 8-2. Manual Slide-Out Deployment Sequence



SLIDE-OUT FEATURES

NOTE: If the slide-out system is supplied with a gearbox override (optional), use the crank handle to move the room.

7. When the room is fully “in” or “out,” apply pressure to the wrench or ratchet and return the brake lever to its engaged position—this will assure that the room is locked into a secured position.
8. Take the unit to an authorized dealer for service.



Figure 8-3. Typical Allegro Bay Slide-Out, Fully Extended

Exterior Features

Towing Hitch

On the rear of the Allegro Bay can be found a Class 3, 5,000-pound towing hitch (Figure 9-1) capable of handling a tongue weight of 500 pounds. This hitch is installed for towing a passenger car to be used when the motor home is parked.

The wire connector installed with this hitch is a standard, seven-pin connector. For more information on the connector, please see Chapter 7 of this Owner's Manual.



Figure 9-1. Towing Hitch

Exterior Sides

The sides of your Allegro Bay are constructed of gel-coated fiberglass (Figure 9-2). To enhance this feature, the end caps are also gel-coated fiberglass. To clean these fiberglass surfaces, only use warm water and a mild cleanser; gently wash with soft cloths. Use of stiff bristle brushes or other harsh abrasives may cause scratches in the fiberglass surfaces.



Figure 9-2. Typical Exterior Side of Allegro Bay

Please note: Tiffin Motorhomes is NOT responsible for the weathering/oxidation of gel-coated surfaces.

Lighted storage compartments are located on the exterior sides of your Allegro Bay. These external compartments provide ample, additional space for your belongings while you are traveling.

When stowing materials in these storage compartments, try to “balance” the resultant weight load from front to rear and from side to side—this will keep the center of gravity of the motor home essentially unchanged and should not adversely affect the handling characteristics of the motor home when it is in motion.

Security Lights

On the Allegro Bay, an exterior security light (Figure 9-3) is a standard feature. A light is installed on the passenger side of the coach to help light that side of the Allegro Bay for added protection.

This light can serve as a “porch light” when the motor home is parked and the awning is deployed so that various activities (e.g., grilling, visiting) at dusk and later can be enjoyed by the motor-home owners and their guests.



Figure 9-3. Security Light on Exterior

Roof & Ladder

The Allegro Bay is manufactured with a fiberglass roof. Proper care and routine maintenance of your roof will assure many years of trouble-free performance. Please see Chapter 14 for details on recommended cleaning instructions.

On the Allegro Bay, a roof ladder (Figure 9-4) may also be included as an additional feature. The ladder (load limit: 200 pounds) is typically used to permit easy access to the roof for routine maintenance and periodic inspections.

The ladder may be hinged so that its lower half can be folded up onto the upper half when the motor home is in transit. When folding up that ladder and securing it, be sure that the ball-lock pin is securely fastened through the locking device to secure the ladder.



Figure 9-4. Ladder

Warning

Do not exceed the maximum rating of the ladder (i.e., 200-pound load limit).

Do not attempt to walk on the roof either while it is wet or when condensation is present from the air-conditioning system, as that surface would be quite slippery.

Hydraulic Leveling Jacks

The following should be done prior to operating the leveling system: Park the motor home on a reasonably level site, free from obstructions and debris. Warn near-by personnel of the intended activity. Put the motor home transmission in “park” and engage the motor-home parking brake. Turn the motor-home engine “off.” Don’t extend any slide-outs until the motor home is level.

Warning

If the vehicle is equipped with a slide-out, DO NOT OPERATE any room extension until the leveling and stabilizing procedure has been properly completed. DO NOT RETRACT

the leveling system until the slide-out room has been retracted. NEVER operate the motor-home leveling system when the slide-out is extended.

Caution

DO NOT LIFT the wheels of the motor home off the ground when leveling—if done, the motor home can “lean” forwards or backwards when supported only by the leveling jacks. Never use the jacks to lift the motor home off the ground to change the tires or perform any under-chassis maintenance—these jacks are not meant for this type of service and this misuse would be very dangerous to the operator.

The Allegro Bay is equipped with hydraulic-leveling jacks. These jacks work in pairs: Front, right side, left side, and rear. **Before extending these motor-home leveling jacks, the engine must be “running,” the ignition switch must be in the “ACC” position, and the transmission must be in “park.”** The parking brake needs to be set and the tires blocked securely; then the leveling jacks can be activated.

Leveling Control System

The leveling system requires only minimal effort from the motor-home user. For manual leveling of the motor home, perform the following steps:

EXTENSION MODE:

On the leveling system control panel (Figure 9-5), press the “on/off” switch to turn “on” the leveling system; this will activate the control panel and a green LED will come “on” to indicate the control system is ready.

Manual Leveling:

1. Press both the “ALL” switch and the “EXT” (extend) switch simultaneously and then release them simultaneously—this will cause all four levelers to extend automatically. The four levelers will each extend automatically and, when each contacts the ground, each will stop automatically. Note: This “all extend” command must be performed first before any other commands will function.



Figure 9-5. Leveling Control Panel on Dashboard

2. PANIC STOP: If it is necessary to stop the leveling process rapidly, any switch can be pressed to initiate a “panic stop” of all four levelers. The total system is still activated. To reset the system, press the “Retract” (RET) and the “ALL” switches simultaneously.
3. Once the levelers have stopped extending, look at the bubble level and adjust the levelers as defined in Step 4. If the bubble in the bubble level is towards the front of the motor home, either extend the rear levelers or retract the front levelers, until the bubble is centered. If the bubble is towards the rear of the motor home, either extend the front levelers or retract the rear levelers, until the bubble is centered.
4. To extend or retract the levelers in adjacent pairs, one can level the motor home in either the extend or the retract mode. To do so, press the extend or retract switch and then release it; then press and hold down the “FRONT,” “DRIVER,” “PASS,” or “REAR” switch to activate the corresponding pair of levelers (i.e., hydraulic jacks). Note the bubble level while performing this operation to make sure that the leveling process is going the way that is intended.
5. Activate the levelers in pairs until the motor home is level. Remember that the levelers can be retracted to facilitate the leveling process.
6. Outside, visually inspect the leveled motor home to assure that all levelers are contacting the ground. If not, activate those needing such until they contact the ground.
7. When the leveling process is completed, press the “on” switch to turn “off” the control panel.

Auto Position Controls:

If the “Auto” position is already set or programmed:

1. Press the “on/off” switch to activate the system.
2. Press the “AUTO” switch. The levelers will extend and automatically reach the pre-set position.
3. Auto Position bump back at completion of Auto Position, the system will check each leveler to assure that its foot is in contact with the ground. During this period, the control panel “WAIT” LED will be lighted.

To set the Auto Position:

1. Look at the control panel; you have an automatic controller if there is a switch labeled “AUTO.”
2. To set the “AUTO” position: (a) Manually adjust the motor home to the position desired. (b) Then press the “on” switch one time to turn the controls “off.” (c) Press the “EXT” switch five times. (d) Press the “RET” switch five times. All control panel LED lights will blink “on” and “off.” (e) Press the “ALL” switch three times. All the control panel LED lights will turn “off.” (f) Turn the controls “on” and simultaneously push the “ALL” and “RET” switches.

RETRACTION MODE:

1. Assure that the slide-out rooms are fully retracted (i.e., they are in their inboard positions).
2. Press the “on/off” switch.
3. Whether using Manual Controls or the Auto Position Controls, simultaneously press both the “ALL” switch and the “RET” switch and then release those switches. The levelers will automatically retract to their fully retracted positions. The leveler indicator LED light will blink red during this activity.
4. Once the levelers are fully retracted, the level indicator LED light (green) will be “on” continuously.
5. Press the “off” switch to turn the power “off” to the control panel.

NOTE: In becoming familiar with the leveling process, consult both this Owner’s Manual and the specific operating instructions that came with the particular leveling system to gain proficiency.

Important

The leveling system should be cycled once a month or whenever the motor home is used to keep the leveling system in good operating condition.

Electric Steps

The Allegro Bay is equipped with electric, three-step doorsteps. As such, the switch (Figure 9-6) to operate these steps is located in the passenger console box. When the power switch for the steps is in the “on” position, simply open the door and the steps will automatically extend. Detailed operation for the electrical, three-



Figure 9-6. Electric Steps Switch (on left)

step, door steps is as follows:

1. Turn the step power switch “on.”
2. When closing the door, the step should retract and lock into the UP position. When opening the door, the steps (Figure 9-7) should extend and lock into the DOWN position.
3. Turn the step power switch “off.” The step should remain in an extended position when the door is closed. Turning “off” the power with the step retracted will hold the step in a retracted
4. position, as well.



Figure 9-7. Electric Steps

5. With the step extended, turn the step power switch “off” and close the entrance door. Turn the vehicle ignition switch “on.” The ignition override system will go into effect and the step will automatically retract.

Caution

If the motor home is driven with the step in the extended position, there is the possibility of causing major damage to both the step and the motor home.

6. With the step switch in the “on” position, turn the vehicle ignition switch “off” and open the door. The step will extend and lock in the DOWN position.

Caution

If the door is opened and closed without allowing the step to extend fully and lock in the “DOWN” position, the step will retract and lock in the “UP” position. When the door is re-opened, the step will not extend. The power switch must be turned “on” for the step to extend.

7. This feature is only operative the first time the door is opened after the vehicle ignition switch is turned “off.” When the ignition switch is “on,” the step will always activate with the door movement, regardless of the position of the step power switch.

Caution

Always be sure to “look before you leap”! When opening the entrance door from the inside, be sure that the step has fully deployed before trying to step outside to avoid falling and possible injury.

Mirrors

This motor home is equipped with convex, remote-controlled, exterior, rear-view mirrors. Always adjust the mirrors for maximum rear visibility prior to driving. If another driver is to drive, be sure the mirrors are readjusted to accommodate the second driver.

These standard black mirrors are adjusted manually. The bottom half of each mirror is convex and is also adjusted manually. The convex portion of the mirror provides a much wider view of the scene, but the apparent “size” and “distance” to the objects in that scene will be distorted.

Detailed instructions for these manual adjustments can be found in the manufacturer’s literature available in the Owner’s Information Package. However, this brief overview of mirror adjustment can begin the process: The top portion of the mirror should be adjusted horizontally so that you can see your own motor home in the one-inch surface closest to the motor home; the remaining portion of the mirror now permits you to see the road behind you. The mirror should be adjusted vertically so that you can see the rear bumper on the bottom of the plane portion of the mirror.

The convex mirrors should be adjusted horizontally so that you can see your own motor home in 1/3 of the mirror. These convex mirrors should then be adjusted vertically to allow you to see any other vehicles alongside your motor home.



Figure 9-8. Mirror

Important

Objects viewed in convex mirrors appear smaller and farther away than they actually are.

Interior Features

Bedspread

As a furnished part of the bedroom suite (Figure 10-1), a bedspread and matching pillow accessories are included in a décor compatible with the rest of the motor home. Other bedlinens (e.g., sheets, blankets, pillows, pillowcases) are the sole responsibility of the motor-home owner and are to be provided by that owner.

For the bedspread and pillow shams, cleaning instructions are “for dry-cleaning only,” as the bedspread was made with materials treated for stain resistance; proper dry-cleaning will prolong the life of these materials.

Minimizing exposure to unnecessary sunlight will prolong and preserve the richness of the colors of the fabrics; so it is advisable to keep the shades closed on the “sunny side” of the motor home, whether parked or in transit.



Figure 10-1. Typical Bedspread

Flooring

The living room and bedroom floor areas (Figure 10-2) are carpeted with filament-nylon carpeting treated with Scotchgard, a stain-resistant coating. In the Owner’s Information Package, there is additional literature from the manufacturer concerning the specifics of caring for the carpeting which, if followed, will prolong the appearance and life of the carpeting.



Figure 10-2. Typical Flooring (Carpeting and Tile)

floor or using a dust mop on it would normally be sufficient.

If more thorough cleaning is warranted, the flooring can be wiped with a damp cloth. Spills can be wiped up with a cloth. In any sandy or “gritty” areas, sweep or vacuum regularly to avoid undue scratching of the laminate surface.

Do not use any “soap-based” detergents or “mop and shine” products as these would leave a dull film on the floor. Do not use any abrasive cleaners, steel wool, or scouring powders as these will degrade the floor surface. Do not wax or polish your floor.

Laminate flooring, when wet, may constitute a slipping hazard; so be careful when washing the floor and allow sufficient time for it to dry before having people walk over its surface. Immediately wipe up any spills or water tracked in by “wet feet” to prevent any slipping on the floor.

For truly tough spots or stains, use a well-squeezed damp mop with laminate floor cleaner—simply squirt and mop the affected surface. Tough stains like shoe polish, tar, and asphalt driveway sealer can be removed with nail polish remover (the active ingredient is acetone); then wipe the treated area with a damp cloth.

Heavy traffic areas will benefit from the use of mats or throw rugs used near the entrances (inside and outside) to catch the dirt before it’s tracked into the motor home.

For protection against denting the floor (e.g., legs of fold-away chairs), one may wish to use floor protectors under such legs, as warranted.

Ceiling

The ceiling (Figure 10-3) in the Allegro Bay motor home is covered with a padded-vinyl headliner which can be easily cleaned with a damp, soft cloth and a mild detergent. Take care to clean around any vent areas to prevent any buildup of dirt, grease, or other accumulations.

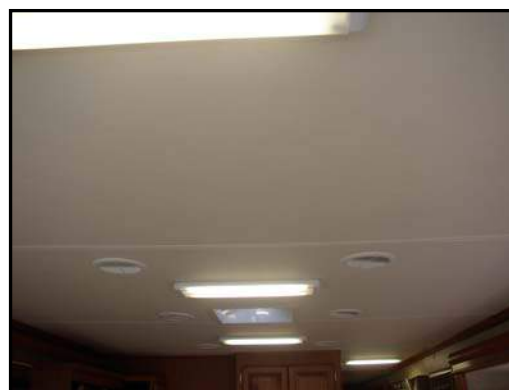

Figure 10-3. Typical Ceiling

Window Treatments

Throughout the Allegro Bay, the window treatments consist of pleated day/night window shades which have two sections (Figure 10-4). When closing the shade, the first section to become visible is the “day” section which is translucent and permits outside, ambient lighting to come into the mclosed, one encounters the “night” section which places a heavier, more opaque material over the window to block out even more light from the outside.



Figure 10-4. Night (top) / Day (bottom) Shade

The “night” setting (Figure 10-5) is generally used in the evening or when a greater degree of privacy is sought. All of the curtains installed in the Allegro Bay are to be dry-cleaned only; no water-based cleaning agents are recommended as they may cause undue shrinking or fading of the fabric.

On some windows, mini-blinds may be installed. Instructions for the proper use and cleaning of any mini-blinds will be found in the Owner’s Information Package furnished with the Allegro Bay.



Figure 10-5. Night Portion of Shade

INTERIOR FEATURES

Plumbing & Bath Fixtures

FRESH WATER SYSTEM

Monitor Panel

The monitor panel (Figure 11-1) permits checking the approximate levels in the fresh, gray, and black water holding tanks; the LP-gas level; and the condition of the house batteries. The monitor panel is generally located in an overhead cabinet above the passenger's seat.



Figure 11-1. Monitor Panel

To use this monitor, simply press the desired status button to obtain a read-out of the fresh, gray, and black water tanks and the present condition of the batteries.

The “empty” indicator light will momentarily light when the button is pressed. If the tank is full, all of the lights will be “on.” Lights are sequentially arranged to indicate fluid levels in approximately third-tank increments.

For example: if the tank selected is approximately two-thirds full, then the indicator lights “E” (for “empty”), “1/3”, and “2/3” will all be lit at the same

time.

On the right-hand side of the monitor panel is the water pump switch. The switch controls the power going to the pump and is used to turn that power either “on” or “off.” There are other water-pump switches nearby the sinks in the kitchen and the bathroom to enable convenient use of the water system throughout the motor home.

Kitchen Sink

The kitchen sink (Figure 11-2) installed is a double-bowl, stainless-steel sink equipped with two sink covers to provide additional counter space when the sink is not in use. The faucet in the kitchen features a single-handle control.

For the sink, cleaning care consists of washing only with mild detergents and water and using a soft cloth for subsequent drying and polishing.



Figure 11-2. Kitchen Sink

Bath Sink, Shower & Accessories

The counter top in the bathroom (Figure 11-3) is a solid surface. When cleaning this surface, use care to prevent scratching or marring it. The typical bathroom accessories include a towel bar and a tissue holder. The single-handled faucet in the bathroom was chosen to match the specified decor.

The bathing facilities installed may be a fiberglass shower or combination shower/tub with a glass shower door or fabric curtain. The tub faucet, hose, showerhead, and bracket are fashion coordinated.



Figure 11-3. Bathroom

Water Pump

The water pump is self-priming and totally automatic, operating on demand whenever water is required. The water pump is used to pressurize the fresh-water system when the unit is not connected to city water. The switches (Figure 11-4) to this pump may be located in the bathroom, monitor panel, and/or sanitation-service compartment. To start the water pump, follow these instructions:



Figure 11-4.
Water Pump
Switch

1. Fill or partially fill the fresh water supply tank.
2. Open the kitchen and bathroom faucets.
3. Turn the water-pump switch “on” and allow the water to fill the water line and the hot water heater.
4. Close each faucet after it delivers a steady stream of water (close the cold-water faucet first). Leave the hot-water faucets “on” until they also deliver a steady stream of water. This procedure will assure that the water heater is filled with water.
5. The water pump should stop running once all faucets are closed.
6. The water pump is now ready for automatic operation. The pump will run when a faucet is open and stop when a faucet is closed.
7. Never allow the pump to run for long periods of time without water being present in the supply tank, as doing so may cause physical damage or blow fuses.

For no water output when the automatic demand system is used, try the following:

Troubleshooting Chart of Automatic Demand Water System for No Water Flow	
SITUATION	SOLUTION
Pump running, but no water flow	<ol style="list-style-type: none"> 1. Fill Tank 2. Clear the water line to the pump
Pump not running	<ol style="list-style-type: none"> 1. Check the pump switch 2. Check the 12-VDC fuses 3. Check the electrical connections 4. Check the battery

All of the water should be drained from the fresh water system when the motor home is not in use for extended periods. For more detailed information regarding the water pump, one should refer to the water-pump manufacturer’s brochure in your Allegro Bay Owner’s Information Package.

City Water Connection

When connecting your motor home to city water, be certain to use the water hose manufactured and labeled for potable-water service--this will assure that the hose selected for use will not alter the taste of the water.

To connect the city water supply to the motor home, connect one end of the hose to the city water supply (Figure 11-5); this connection will usually be to a faucet or valve similar to your garden hose valve at home.

Turn the city water supply “on” for a few seconds to clear the line. Once the hose has been flushed, turn the supply “off.” Connect the other end of the hose to the city-water connections on the motor home. Once the city-water fill valve is opened, water is supplied to the freshwater system including the hot water heater, faucets, and toilet.

Turn “on” the water supply and open all of the faucets to clear any trapped air within the plumbing lines within the motor home. Once any air pockets have purged from the water lines and water flows freely, close all of the faucets.



Figure 11-5. City Water Connection

The city water supply is pressurized (usually 60-80 psig); therefore, the water pump is not needed when the water system of the motor home is connected to the city water system. To disconnect the motor home from the city water supply, close the valve and remove the hose from the city water supply. Disconnect the hose from the city-water connection, drain it, and store the hose in the water compartment of the motor home.

Filling the Freshwater Tank

The freshwater tank is normally filled from the city-water connection. The city-water valve located in the service compartment near the water connection determines whether the city water is going through the motor-home water system or into the freshwater tank.

Important

Be sure the potable-water fill cap is removed when filling the freshwater tank from a city-water supply (which is typically under 60–80 psig pressure). Failure to do so

may result in inadvertent expansion of and possible rupture of the water tank.

Since there is not an automatic shut-off when filling the freshwater tank, check the level from the monitor panel while filling the freshwater tank on the motor home. The excess water should be vented onto the ground from an overflow pipe installed in the vent pipe when the capacity of that tank has been reached. This pipe is installed in the freshwater tank to prevent possible tank rupture from inadvertent overfilling.

All of the water should be drained from the freshwater system when the motor home is not in use for an extended period of time.

Sanitizing

To assure complete disinfecting of the freshwater system, it is recommended that the following procedure be performed on a new system, on one that has not been used for a length of time, or one that may have become contaminated. This procedure is also recommended before long periods of storage, such as during the winter months:

1. Drain the freshwater tank by opening the drain valves. There is one valve for each water tank. All of the faucets should be in the closed or “off” position.
2. Prepare a chlorine solution using one gallon of water and one-half cup of chlorine bleach (5% sodium-hypochlorite solution). Prepare enough of the chlorine solution to administer one gallon of solution for every 15 gallons of tank capacity. For sanitizing this tank, prepare 4½ gallons of the chlorine solution. This mixture puts a 50 ppm (parts per million) residual chlorine concentration in the water system that will act as a quick-kill dosage for harmful bacteria, viruses, and slime-forming organisms. Concentrations greater than 50 ppm may damage the water lines and/or the tank.
3. Once the freshwater tank is empty, close the drain valves in the water tank.
4. Pump the chlorine solution into the tank by first placing the winterizing hose into the chlorine solution. Close the valve from the fresh water tank to the pump and open the valve from the solution to the pump. Turn the tank fill valve from “city water” to “tank fill.” Turn “on” the water pump until all of the solution is pumped into the freshwater tank.
5. Turn “off” the water pump. Then close the valve to the solution. Open the valve from the tank to the water pump. Fill the water tank with the city water tank fill (or by using the same method as was used to put the sanitizing solution into the tank). Remove the water filter (located in the sanitation compartment outside the motor home) and install the bypass pipe to allow the sanitizing solution access to the faucet. Open each faucet, in turn, including the kitchen faucet, bath faucet, inside and outside showers, turning “on” both the hot and cold

faucets, and flushing the toilet until all of the air has been purged from the pipes and the water runs freely. The entire system will then be filled with the sanitizing solution.

6. Allow the 50 ppm disinfecting solution to stand in the system at least four hours.
7. Drain the system and flush it with freshwater. The water system needs to be flushed with water repeatedly, if necessary, until there is no chlorine taste or smell left in the system. To remove any excessive chlorine taste or odor that might remain, prepare a solution of one quart of vinegar to five gallons of water. “Rock” the tank containing the solution by moving the motor home forward and backward several times to clean the tank; then drain that tank and refill with clean water.

Water Filter (Optional)

This unit may be equipped with an optional water filter (Figure 11-6) which must be removed before disinfecting the freshwater system. First remove the water filter cartridge. The water filter is located in the sanitation compartment on the outside of the motor home. The filter will remove chlorine, dirt, and other matter. The filter will also eliminate most phenol (or similar) odors and tastes while delivering sparkling, taste-free water for drinking and cooking.



Figure 11-6.
Water Filter

The filter is not guaranteed to remove the tastes and odors of iron and sulfur. To remove these impurities, one would need to chlorinate the water. Replacement filters are available that will filter iron and sulfur. Ask your dealer or RV supply center about purchasing an iron and sulfur filter, if such is desired.

If you are traveling in an area where the water has a high iron and sulfur content, then add one tablespoon of chlorine bleach to every 10 gallons of water in your tank--this will precipitate the iron or sulfur so that the filter can remove those impurities.

If you are at a site where the unit is connected to a city water supply, you will not be able to chlorinate the system because the water flows straight to your faucets and not through the freshwater tank. Filters should be changed every 6-12 months depending on the quality and quantity of water that is used in your motor home.

Water Heater Bypass System

The water heater bypass valve (Figure 11-7) is located in an outside compartment behind the water heater. By closing the water heater supply valve and opening the bypass valve, one can divert water away from the water heater.

This process is performed when winterizing your motor home. Using the bypass valve will keep antifreeze out of the water heater when winterizing the motor home. Draining the water heater during



Figure 11-7. Water Heater Bypass Valve

winterizing is a MUST. If not properly drained, the water heater would be subject to damage from possible freezing/thawing cycles. To prepare the motor home for reuse, switch the bypass valve back to its normal position and re-fill the water heater.

Freshwater Lines

Vibration and flexing encountered when the motor home is traveling can cause pipes and fittings to become loose. Check all of the plumbing connections for leaks at least on an annual basis. If the water pump still runs when all faucets are turned “off,” check for a possible leak. Be sure that the drain valves are closed.

Connections at the kitchen and bathroom faucets normally seal by hand-tightening them and then making an additional half-turn with a wrench. If a fitting leak persists, disconnect it completely and visually inspect it for mineral deposits or foreign material stuck on the sealing surfaces. Clean the surfaces thoroughly and reinstall the fitting.

Take the motor home to an authorized Tiffin Motorhomes service center for additional repairs if the water system continues to leak. Follow the winterizing instructions given in Chapter 14 to reduce risk of leaks caused by cracks from freezing pipes. Left unchecked, freezing damage can be extensive and expensive.

WASTE WATER SYSTEMS

General Information

The waste drainage system was designed to provide adequate and safe storage and/or disposal of waste materials. All of the manufacturing materials used in the fabrication of this system are tested by a nationally-recognized testing laboratory. The drainage system uses plastic piping and fittings connected to the sinks, toilet, and holding tanks. This plumbing permits the drainage of these fixtures to an outside termination.

The motor home should be reasonably level for best operation of both of the wastewater systems (there are two, separate wastewater systems). The gray-water system is for wastewater from the sinks and shower. The black-water system is for sewage waste from the toilet. Each wastewater tank has its own control valve and both drain through a common sewer-drain hose.

Toilet

The toilet (Figure 11-8) in the Allegro Bay motor home is a plastic one. The toilet operates with water from either the fresh water tank with the water pump “on” or the city water supply. Before using the toilet, add water to the bottom of the tank. Refer to the “BLACK WATER TANK” instructions elsewhere in this chapter. The toilet flushes waste directly into the black-water holding tank.

The toilet uses high-velocity water injection to produce swirl effect in the bowl. The greatest problem that causes stool solids to accumulate in the holding tank is lack of liquids.

When using your toilet, it is wise to fill the toilet 3/4 full of water--this will help wash the solids away from directly below the toilet and to assure complete dumping of the holding tank. To add water to the toilet bowl, press down on the flush lever until the desired water level is reached. To flush the toilet, push down on the lever until the water swirls. A small amount of water should remain in the bowl.

The toilet should be cleaned regularly for maximum sanitation and operational efficiency. Clean the toilet bowl with a mild bathroom cleaner. **DO NOT USE CHLORINE OR CAUSTIC CHEMICALS, SUCH AS LAUNDRY BLEACH OR DRAIN-OPENING TYPES, AS THEY WILL DAMAGE THE SEALS IN THE TOILET AND DUMP VALVES.**



Figure 11-8. Toilet

Refer to the toilet-manufacturer’s owner’s manual in your Allegro Bay Owner’s Information Package for complete instructions and a detailed troubleshooting guide.

Caution

It is important that you use as much water as possible with each flush. This will help prevent tissue and other solids from clogging the holding tank outlet.

P-Traps

Each of the sink drains, the shower drain, and the washing-machine drain (if so equipped) has a water trap (P-trap) to prevent holding-tank odors from entering the motor home. These traps must have water in them to trap odors. When the motor home is in motion, the water in these traps may splash out of the sink and shower drains. When the motor home is stored, the water may evaporate from these traps

allowing odors to enter the motor home. If this occurs, run water from the faucet into the drain, thus allowing water to fill the traps again.

Black-Water Holding Tank

The “black water” (i.e., sewage) holding tank is located directly beneath the toilet. Before using the toilet, you will need to treat the tank with water that is mixed with an odor-controlling chemical. These chemicals are readily available at any RV supply store. Be careful not to spill the chemicals on your hands, clothing, or the carpet because such may cause a permanent stain. Pull the toilet levers forward to allow the chemicals to mix with the toilet water. Continue pulling the toilet levers until a depth of at least one inch of solution is directly under the toilet. Release the levers and the waste tank is now ready for use.

Caution

Use only approved RV odor-controlling chemicals in the holding tanks. Products containing ammonia and petroleum will damage the ABS plastic holding tanks and seals.

Gray-Water Holding Tank

The gray-water holding tank is located in the underbelly of the vehicle. It is primarily used for the drainage from the kitchen and bath sinks and the shower. No special preparation is needed for the subsequent use of this tank.

Wastewater Disposal

Both of the holding tanks terminate in a valve arrangement (Figure 11-9) that permits draining each tank separately or together. It is recommended to drain the black-water tank first before draining the gray-water tank. This procedure permits the water from the gray tank to wash the black-water residue from the drain lines and hose. The valves that open to release the water are called gate valves.

The blade that closed the opening in the sewer drainpipes is connected to the T-handle to release contents of the tank(s) when pulled. The sewer line must be securely capped during self-containment use to prevent leakage of waste materials onto the ground or pavement. Do not pull the holding-tank gate valve “open” when the protective cap is



Figure 11-9. Sanitation Compartment with Wastewater Disposal Connection (Black Valve) and Wastewater Hose (Brown Hose)

installed on the pipe. Always drain the tank into an acceptable sewer inlet or dump station; never dump tank contents into the environment.

Whenever possible, drain both the holding tanks prior to traveling. The carrying capacity of your motor home will be reduced if water is left in the black or gray tanks (each gallon of water transported adds about 8.3 additional pounds to the weight of the motor home).

The holding tanks should only be drained when they are at least 3/4 full. Doing this will provide a sufficient volume of water to allow the complete flushing of waste materials in the drain lines and hose. If the tanks are not 3/4 full, add enough water to allow for sufficient flushing.

To empty the wastewater tanks, connect the adapter, supplied with your motor home, to the drain hose. If the adapter is lost or broken, another one can readily be purchased from any RV supply store. Once you have placed the adapter on the drain hose, it can remain there for the life of the hose. One end of the hose threads up through the hole in the bottom of the service compartment and the other end of the hose feeds into the sewer at the dump station. Unscrew the cap from the drain. Connect the hose, with the adapter in place, to the drain fitting. Open the gate valve completely by pulling on the T-handle. The tank will start to drain as soon as the T-handle is pulled. After you have drained the black-water tank, immediately drain the gray-water tank. This procedure helps to flush the black water from the sewage hose.

When both of the tanks are empty, flush them with a freshwater rinse before you close the valves. The gray tanks are easily flushed by pouring a couple of gallons of water into a sink drain. The drain outlet is engineered for quick release of the drain hose adapter. Always close the gate valves and secure the end cap to prevent leakage while the motor home is in transit. After draining the black-water tank, it is recommended to add a holding-tank deodorant to help control the odor and break down the solids. Follow the instructions given on the holding-tank deodorant package. When using dump stations for draining the holding tanks, keep other travelers in mind. Please practice good housekeeping! Leave the dump stations in good order. Above all, **do not pollute!**

Sewer Connection and Camping

When camping at parks with sewer connections, it is important to keep the black-water holding-tank gate valve closed at all times, except when dumping. The gray-water tank can be kept open while hooked to a sewer connection; but again, the black-water tank must be kept closed. This is done so that an ample quantity of liquid remains in the black-water tank to provide a smooth flow through the gate and drain valves when dumping.

Sufficient liquid in the tank causes a swirling action that should take any accumulated solid wastes with it. Accumulation of solid wastes in the black-water tank can be avoided by keeping the gate valve closed when connected to the sewer connection. If the valve is open, solid wastes may accumulate in the tank which may eventually result in costly repairs.

Caution

The gray-water tank valve must be in the “open” position when operating the optional washing machine.

No-Fuss Flush

This vehicle may be equipped with a flushing system for the black-water holding tank. When draining your sewer tank, attach a water hose to the sewer spray connection. After the tank is drained, leave the gate valve “open” and open the water valve to allow water to spray inside the black-water tank; this will clean the inside of the tank of any debris that may be left inside the tank. After this is done, disconnect the freshwater hose and close the gate valve.

Caution

Be sure the gate valve is “open” when flushing the tank. Do not use the same hose for the No-Fuss Flush that is used for filling the fresh water tank.

Exterior Shower

Your Allegro Bay has an exterior shower (Figure 11-10) for your use and convenience outside. That exterior shower is located in the service compartment, which is located on the driver’s side of the motor home. The exterior shower feature allows you to do such things as rinse off sand or grass, muddy shoes, or bathe yourself outside of your motor home.

The faucet operates just as it would in your kitchen or bathroom. In addition to the shower itself, there is an outside courtesy light to permit use of these amenities under low-light conditions.



Figure 11-10. Exterior Shower in Sanitation Compartment

Construction Features

Construction Notes

Your Allegro Bay manufactured by Tiffin Motorhomes is constructed of the finest materials available by well experienced craftsmen at the Tiffin Motorhomes manufacturing facilities in Red Bay, AL. Every care and concern have been taken throughout the total manufacturing process to assure you of the finest motor home available in the marketplace today

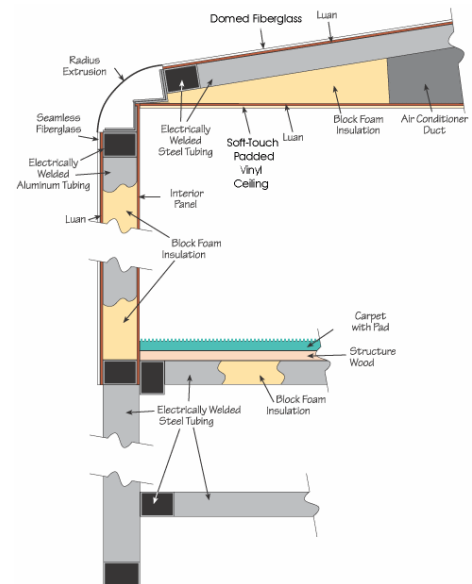

Figure 12-1. Typical Chassis

The Allegro Bay is built either on a Ford, Freightliner, or a Workhorse chassis (Figure 12-1). The floor decking is constructed of 1/2" OSB board to provide desired rigidity and firmness in the floor of the motor home. The floor is insulated with block foam to provide both thermal insulation and sound deadening to keep road-surface noises from unduly entering the motor home. The motor-home roof is also insulated with block foam to

provide an adequate barrier to heat loss or gain through the roof.

In the Allegro Bay, each sidewall is manufactured to provide essential strength and durability and is also insulated to assure the comfort of the enclosed spaces. Sidewalls are constructed of aluminum or steel framing, insulated with 1 1/2"-thick block foam insulation. Framing and insulation are laminated between interior décor board and gelcoat fiberglass on the exterior to provide superior strength and rigidity. The insulation provides a sound-deadening barrier from outside noises and more effective thermal control of the enclosed cabin in the motor home, thus allowing greater efficiency of the heating and air-conditioning systems.



Typical Floor Plan

Although there are many variations of the floor plans for the Allegro Bay, a "typical" floor plan is presented to show the relative components of the Allegro Bay.



Windows, Awnings, Vents, & Doors

Windows

The windows (Figure 13-1) on the Allegro Bay are of the sliding type. Optional double-pane windows also provide additional thermal control (i.e., insulation) to maintain interior temperatures better. In the optional, double-pane windows, a “dead air” space (filled with a dry, inert gas) is sealed between the two panes of glass—this “dead air” space provides additional thermal insulation for the windows and prevents them from fogging internally. Additionally, there may be a reflective coating on the windows to reflect back a portion of the sunlight to reduce the heating of the motor-home interior and to reduce the effects of the sun’s “bleaching” of interior fabrics (curtains, upholstery).

For both the driver’s and the passenger’s windows, additional sun

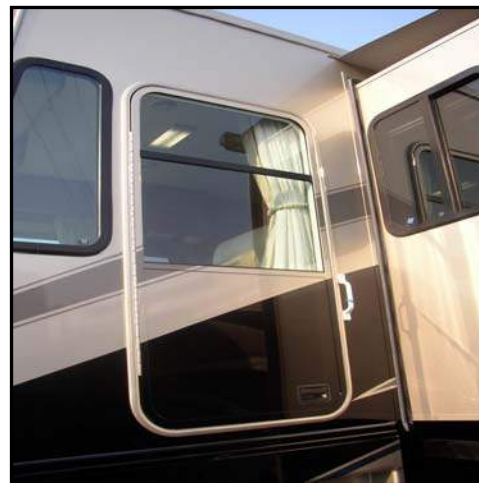

Figure 13-1. Windows on Driver's Side



Figure 13-2. Emergency Exit

visors are available to permit blockage of the sun’s rays which may interfere with driving. These shades can be deployed, as needed, and then moved out of the way when no longer desired.

In the bedroom, one particular window (Figure 13-2) will be marked with an “EXIT” label—this is an emergency escape to be used only when normal exits are blocked or inaccessible. To use this emergency escape, merely lift the red handles at the bottom of the window and push outwards to open the window.

Should it be necessary to use this exit, please look for a secure footing when exiting so that no personal injury is sustained in the process. It is also prudent, when parking the motor home, to be aware of where this “emergency-exit” window will be situated so that it is not inadvertently blocked or impeded (e.g., by a tree or pole) from its normal, intended operation, should such become necessary.

Awnings

Your Allegro Bay may be equipped with an optional, power patio awning (Figure 13-3). If so, use the following directions to operate the awning properly:

NOTE: You may first have to program the key fob which can remotely activate the awning; please consult the owner’s manual for the power awning for directions on the programming process.

Extending the Awning:

1. First, examine the area where the awning is to be deployed and



Figure 13-3. Optional Power Awning Controller

make sure that there are no obstructions that may impede the opening of the awning.

2. Make sure that the weather conditions warrant opening the awning; for example, the wind isn't too blustery or no major storm fronts are soon to be expected in the immediate area.
3. One can either use the **control box** or the **key fob** (Figure 13-4) to deploy the awning. For the control box, press the rocker switch upwards to extend the awning; for the key fob, press the "extend" button on the key fob—either action will cause the awning to deploy to its fully extended position. If there is a remote switch inside the motor home, one can activate the awning from inside the motor home by pressing the rocker switch upwards to the "extend" position.



Figure 13-4. Key Fob Awning Controller

NOTE: If one wishes to protect the awning automatically from possible windy conditions which may damage the awning, set the wind sensor switch on the console to the "on" (usually upper) position. To disable this function, set the wind sensor switch to the "off" (usually down) position.

Caution

Since damage resulting from weather is not under warranty, anytime a heavy or prolonged rain or blustery winds are anticipated, it would be advisable to close the awning. Similarly, if the awning is to be left unattended for any prolonged length of time, it would be prudent to close that awning.

Retracting the Awning:

1. Make sure that nothing (e.g., nearby tree, patio torches) obstructs the intended movement of the awning.
2. One can either use the **control box** or the **key fob** to retract the awning. For the control box, press the rocker switch downwards to retract the awning; for the key fob, press the "retract" button on the key fob—either action will cause the awning to retract to its fully closed position. If there is a remote switch inside the motor home, one can retract the awning from inside the motor home by pressing that rocker switch downwards to the "retract" position.

NOTE: If one wishes to protect the awning automatically from possible windy conditions which may damage the awning, set the wind sensor switch on the console to the "on" (usually upper) position. To disable this function, set the wind sensor switch to the "off" (usually down) position.

Emergency Retracting Procedure for the Awning:

If the automatic retracting of the awning isn't possible, one may manually close the awning using the following procedure:

1. Slide the pull strap (provided) into the utility slot of the Fabric, Roller Tube, Torsion Assembly (FRTA) [see the Weather Pro Power Awning Diagnostic Service Manual {Dometic Corporation} for illustration].
2. While one person holds the pull strap, remove the bolt in the top of the right top casting (see picture in the awning owner's manual for details). The FRTA will retract (i.e., "roll in") once the bolt is removed. Walk the awning to its retracted position (i.e., fully closed).
3. When the awning is fully retracted, replace the bolt to prevent the awning from accidentally opening during travel. NOTE: After this procedure has been performed, have the awning serviced by a Dometic Service Center or a qualified service technician before any further attempts are made to open the awning.

The manual patio awning is standard on the Allegro Bay. Use the following directions to operate the manual awning properly:

Extending the Awning

1. Loosen the black, adjustment-lock knob on either side of the main arm of the awning. Flip the travel lock latches upwards.
2. By using the pull rod provided with the awning, reach up and pull the locking lever forward to release the awning.
3. Hook the rod onto the loop of the pull strap and pull the awning all the way out to its fully extended position.
4. Slide one rafter arm up until that arm snaps into place. Push down on the main arm to remove any slack that may remain in the fabric of the awning; then tighten the black adjustment knob. Repeat this process for the other side.
5. Slide the pull strap to the right end of the roller and wrap that strap around the main arm.
6. Pull up on the lift handle and raise the arm assembly to the desired height. Swing the handle "in" and allow the lock button to snap into one of the holes. Repeat this process on the other side of the awning.



Figure 13-5. Awning (Fully Retracted Position)

7. Press the release lever at the bottom end of one main arm; pull the arm assembly outward to a vertical position and readjust the height. Repeat this process on the other side of the awning. During any rain, lower one end to permit water runoff.

Caution

Since damage resulting from weather is not under warranty, anytime a heavy or prolonged rain or blustery winds are anticipated, it would be advisable to retract the awning. Similarly, if the awning is to be left unattended for any prolonged length of time, it would be prudent to retract that awning.

Retracting the Awning

1. Raise the lift handle to release the lock button. Lower the main arm to the stop plug. Swing the handle “in” to engage the lock button in a hole. Repeat on the other side of the awning.
2. Loosen the black adjustment knob, lift the slider catch, and then slide the rafter arm downwards to the bottom of the main arm. Leave the black adjustment knob loose. Repeat this process on the other side of the awning.
3. Grasp the pull strap and pull towards you. Flip the locking lever to the “ROLL UP” position. Hold the awning in the “down” position until you are ready to roll up the awning. **BE CAREFUL** – the awning will try to roll up as soon as the locking lever is flipped to the “ROLL UP” position.
4. Slide the pull strap to the center and, by using that strap to control speed, allow the awning to return to the side of the motor home. Allow the strap to wind diagonally to prevent a bulge in the fabric of the awning.
5. Tighten the black adjustment knob and flip the travel lock latch down. Repeat this process on the other side of the awning. The awning is now fully retracted and is ready for travel.

NOTE: Be sure that the awning is fully locked into position on both arms before travel. Failure to do so may cause the awning to deploy when the motor home is in motion.

Vents

The kitchen has a 12-VDC Fantastic vent fan (Figure 13-6) installed to exhaust kitchen odors and heat buildup from cooking. The vent fan can also be used to change the air in the motor home (e.g., if it becomes musty or smelly). To operate the fan, first turn the knurled knob to raise the external cover on the



Figure 13-6. Exhaust Fan

outside of the fan, then turn the fan “on” to the desired setting. When the fan is turned “off,” remember to close the outside cover on the fan by turning the knurled knob—this will keep any form of precipitation or particulates (e.g., dust, pollen) from entering the motor home.

The bathroom also contains a 12-VDC, vent fan which is controlled by an “on/off” switch mounted on the bathroom wall.

Doors

Caution

Always secure the dead bolt lock while the motor home is in motion to prevent accidental opening of the entrance door.

The primary entrance door (Figure 13-7) to the motor home is a radius door having a key lock and a dead bolt for additional security. There is also a screen door (Figure 13-8) associated with the entrance door; the screen door will permit increased air circulation when the entrance door is open. To enjoy this benefit, the screen door is operated independently of the entrance door.



Figure 13-7. Entrance Door

To protect the contents of the motor home and the very motor home itself, it is prudent to lock the motor home when one is to be away for any length of time. Both the key lock and the dead bolt should be used for maximum security of the motor home.



Figure 13-8. Screen Door

Routine Maintenance

EXTERIOR CARE

Important

Damage caused by improperly performed maintenance or inadequate maintenance is not covered by your Tiffin Motorhomes Limited Warranty.

Washing

The exterior (Figure 14-1) of your new motor home is made of pre-finished fiberglass. Frequent washings and thorough cleanings are required to prevent damage to the motor-home finish after exposure caused by damaging salts, calcium chloride, road tar, tree sap, insects, and other foreign material. Damage caused by exposure to these items is not covered by your warranty agreement. Never wash the motor home in direct sunlight, while the motor home is hot, or with hot water.



Figure 14-1. Motor Home Exterior

Any accumulation of mud and dirt under the body can cause damaging rust on steel parts. Corrosive materials, such as those used for ice and snow removal and dust control, also can accumulate on the underside of the motor home. These accumulations, especially in vehicular areas where mud and other foreign materials could collect, should be removed by flushing those areas (e.g., the underside) of the motor home regularly with water. The chance of corrosion can be minimized with frequent washings of the motor home.

When washing the motor home, make certain that the undercarriage and the wheel wells are thoroughly cleaned, as well as the exterior of the motor home. Do not use strong soaps or detergents for washing the motor home. Always use a mild soap in warm water, a commercially prepared product for automotive finishes, or your local car wash to wash your motor home properly.

Be careful when using any pressurized washer to avoid loosening any exterior decals or sealants and the like. After washing, carefully inspect the caulking around the window frames and vents and any other joints to see if any seal separations have occurred. Should any re-caulking be necessary, it is relatively simple and is considered to be routine maintenance which is the responsibility of the owner.

Important

Never use a strong solvent, such as lacquer thinner or harsh abrasives, on any of the exterior-painted surfaces.

Waxing

The exterior finish will require a routine waxing. When water will not bead and roll off a freshly washed motor home, a new coat of wax is needed. Wax not only improves the appearance of the motor home, but it also protects the finish against oxidation and corrosive materials. The recommended type of wax is one that is compatible with painted and gel-coated fiberglass finishes and contains an UV (ultra-violet) inhibitor. Buffing with a polishing compound will improve a dull or discolored finish.

Important

When using a polishing compound that does not contain a wax preservative, reapplying a coat of hard wax after polishing is recommended.

Seals

The seals (Figure 14-2) around the doors, windows, vents, slide-out trim, and external seams should be checked at least semiannually. Additionally, the roof seams should be inspected for cracking or peeling at least annually. If any deterioration is noted during a routine-maintenance inspection, reseal the seams or seals with an approved sealant to prevent any leaks.

Your Tiffin Motorhomes dealer can perform the resealing inspections and subsequent work, if any, for you. It is recommended that a Tiffin Motorhomes authorized service center perform these inspections periodically and perform necessary resealing when necessary.



Figure 14-2. Seals of Windows and Doors

Proper Sealants for Application

The following sealants are recommended for specific sealing applications, as noted in the table:

Recommended Sealants for Specific Sealing Applications	
SEALANT	APPLICATION
Plas-T-Cote	Metal or fiberglass roof
Surebond #SB-140	Rubber laminated to metal roof and ALL SKYLIGHTS
Carlisle #502-LSW Self-Leveling Sealant	Rubber roof over wood base
Silicone Sealant	To cover butyl and other sealants; not to be used as the main sealant
Parbond	To seal across tops of windows and the like on exterior surfaces where silicone is not used

Striping and Decals

The striping and decals (Figure 14-3) on your motor home normally require very little maintenance.



Figure 14-3. Striping & Decal

Treat these as you would any painted surface on your motor home. Wash them with mild soap and warm water or any retail car soap. Never wash the motor home in direct sunlight, while the motor home is hot, or with hot water. Rinse thoroughly to prevent accumulation of any soap residues.

Use caution with high-pressure wash nozzles. Keep such nozzles at least 18 inches from the edge of the decals during any washing operations. If this is not followed, high-pressure water nozzles may cause the decals to loosen and subsequently to peel. Test small sections of decals when using any type of cleaning solution.

Important

Do not use solvents such as acetone, MEK, toluene, and the like on the decals. Any solvent including alcohol may soften and smear colors. Do not use lacquer thinner or paint thinner on decals. Do not overcoat the decals with clear paint. Do not allow gasoline or other fuels to come into prolonged contact with the decals. However, if this should occur, immediately flush the affected area with water.

Important

Do not use harsh detergents, acids, or abrasives which may scratch or dull the surfaces. The applicator cloth, sponge, or soft-bristled brush should be non-metallic and non-abrasive.

Important

Remember to check periodically the tightness of your wheel lug nuts.

Roof Care and Maintenance

Proper care and maintenance of your motor home, including your roof, is important for sustained, trouble-free performance. Normal maintenance is simple and easy and does not require special materials. The roof of the motor home is fiberglass and can be cared for in the conventional manner. Keep the roof clean; one should clean the roof at least every three months. The roof should be professionally inspected by a dealer for leaks. Sealant may be necessary in the second year of ownership.

Warning

Use caution when working on the top of your motor home. The wet roof may be extremely slippery and, as such, a possible safety hazard.

Moisture Management

This section outlines important recommendations to manage moisture in your motor home to avoid moisture-related damage, such as mold, which is caused by moisture. The materials and methods used to construct your motor home were selected in part to minimize air leakage and to create a weather tight exterior shell. However, in order to protect your investment and reduce the risk of moisture-related damage and costly repairs, attention and care has to be taken to manage moisture inside your RV. **Note:**

These are only suggestions intended to minimize moisture-related issues with your motor home. If any concerns arise, contact Tiffin Motorhomes' Service Department at (256) 356-0261.

Interior Care of Your RV

Signs of excessive moisture can be obvious, such as water droplets forming on surfaces or wet carpet. Conversely, signs of excess moisture can be subtle, such as condensation forming on metal surfaces. When symptoms appear it is important to timely determine the cause of the excess moisture and take appropriate corrective action to prevent moisture related damage.

Control Relative Humidity

Monitoring and controlling relative humidity within the motor home is one of the most important steps to minimize the risk for moisture-related damage. Ideally, relative humidity should be at 60% or less. Relative humidity can be monitored utilizing a portable hygrometer (Figure 14-4), a small device that measures temperature and relative humidity. Hygrometers are available at electronics or building supply stores. Use exhaust fans, the air conditioner, and/or a portable dehumidifier to manage moisture inside the RV to maintain relative humidity at 60% or less. In cold climates, relative humidity may need to be at 35% or less to avoid window condensation issues. If the motor home is used the majority of the time in a hot-humid climate, it may be difficult to keep relative humidity below 60%. A dehumidifier will help, but is important to check the condensation (water) collection bucket regularly or discharge the condensation (water) directly to a drain.



Figure 14-4. Portable Hygrometer

Avoid Drastic Thermostat Setbacks

Cooler surface temperatures increase the potential for condensation and surface mold growth. To minimize the opportunity for condensation to form on interior surfaces, maintain a comfortable temperature in your RV, and avoid nighttime setbacks of 10 degrees or more. Drastic setbacks that reduce the indoor air temperature quickly can increase the chance for airborne moisture to condense on cool surfaces such as windows. If you are away from your RV for an extended number of days, it is recommended that you do not set the temperature back without taking other measures to manage relative humidity, including operating a dehumidifier with a continuous drain.

Manage Window Condensation

Window condensation issues can be identified by water or ice-build up, usually at the base of the window. The majority of these problems can be addressed by managing moisture generated inside the motor home. Minor condensation issues are not unusual, especially for RVs used in colder climates. The key is to manage this small amount of moisture if evident by wiping the surface, and as discussed in the “Control Relative Humidity” section, maintaining a reasonable relative humidity within the unit. To help minimize window condensation, use exhaust fans vented to the outside, avoid drastic changes in thermostat settings, do not use “vent-free” heaters and use window coverings wisely. For example, make sure to open curtains or blinds during the day to allow air to circulate and warm the window surface.

Carpet Care and Moisture Management

To keep your carpet serviceable and looking new for years to come, the carpet should be cleaned when it shows signs of discoloration or traffic patterns. A steam cleaning system should be used to clean the carpet unless other noted in your warranty information. To manage moisture from the cleaning process, the cleaning system needs to be capable of extracting the excess water from the carpet after it has been cleaned. **Important:** Be sure the carpet is thoroughly dry before closing up the RV for storage. Water from the cleaning process can cause significant damage to the RV if the carpet is not completely dry before closing up the motor home for an extended period.

Cleaning Tile and Wood Floors

Most floors only require a mild detergent and warm water for cleaning. More water on the floor is not always better for cleaning. Use a damp cloth to clean on a regular basis rather than wet mopping each time. For more information regarding the maintenance of the tile and wood floors, see the section entitled, “Woodwork and Floors.”

Storage and Other Isolated Areas within the RV

Storage areas are more difficult to condition since the areas are isolated from the main body of the RV. The surfaces of these areas are more at risk for condensation and surface mold growth. To minimize this risk, clean storage areas regularly, and allow an air space between stored items and the exterior wall to promote air circulation.

Use of Un-Vented Combustion Equipment

Un-vented combustion equipment, such as propane stovetops are a source of moisture within the RV. For every gallon of fuel consumed, approximately one gallon of water vapor is evaporated into the air. Whenever possible, operate an exhaust fan in combination with the use of any un-vented combustion appliance within the RV. Water vapor and other combustion byproducts should be vented to the exterior of the RV. The RV owner should strictly follow use and maintenance instructions for safe operation of any combustion equipment, particularly un-vented equipment.

Exterior Care of Your RV

The exterior shell of the RV is the primary weather and moisture barrier. Over the life of the vehicle, the shell will require regular care and maintenance in accordance with other instructions for exterior care. The shell includes the roof, sidewalls, windows, doors, and under-floor of the vehicle. Particular attention needs to be devoted to ensure these components are maintained to ensure a tight barrier against bulk water intrusion. The shell should be inspected periodically for tears, gaps, and condition of sealants in accordance with this owner’s manual. Areas that require maintenance should be resealed utilizing a similar, high quality sealant used by the manufacturer. Particular attention should be devoted to ensure the slide outs are functioning properly. Each time a slide out is used it should be inspected to ensure



Figure 14-5. Inspecting Slide Out Gasket

proper operation and sealing (Figure 14-5). The slide out gaskets should also be inspected to ensure proper sealing when the slide out is operated.

Use of Your RV

It is important to remember that the square footage of an RV is significantly less than that of a single family residence. This fact alone will elevate the relative humidity because there is less volume of air to help absorb or dissipate the humidity. For example, showering and cooking create a lot of humidity in a small area. In these instances, use of an exhaust fan and opening windows should reduce the relative humidity, particularly when living in the RV for an extended period.

Severe Environments

Prolonged use of your RV in severe environments—for example in extremely cold or hot-humid climates, will require extra care and maintenance to avoid moisture-related issues. In both extremely cold and hot-humid climates more attention needs to be focused on controlling relative humidity within the RV. It also may require the use of a portable dehumidifier to manage relative humidity within an acceptable range. This is discussed further in the “Interior Care of Your RV” section. If you have any questions about moisture-related issues in the environment you plan to use the RV in for a majority of the time, contact Tiffin Motorhomes’ Service Department at (256) 356-0261.

Storage of Your RV

During those periods when your motor home is not in use, care must be taken to ensure moisture sources are addressed. Ideal storage of your RV would be in an enclosed climate controlled environment. When this is not possible, the following steps should be taken to ensure moisture is controlled:

- Turn off all water sources
- Turn off all combustion appliances
- Drain the water tank(s)
- Drain the water heater
- Open all closets, cabinet doors and drawers
- Close all windows and entrance doors
- Open a vent or a window enough to allow for some limited ventilation air flow, but not so far as to allow snow or rain to enter
- When storing the RV in high humidity climates (ambient relative humidity is greater than 60% year round), add a dehumidifier drained to exterior to control humidity inside the RV during storage

- Refer to other sections of this owner’s manual for additional recommendations

Modifications to your RV

Consult Tiffin Motorhomes for guidance prior to making any modifications to your RV. It is important that changes be completed by a qualified service firm to ensure moisture intrusion or accumulation problems do not occur.

Wet Areas

Areas that are exposed to water spills or leaks should be dried as soon as possible and definitely within 24-48 hours. Drying areas quickly minimizes the chance for moisture damage and possible mold growth, which can begin to form colonies within 48 hours. A variety of methods can be used to help the drying process:

- Remove excess water with an extraction vacuum
- Use a dehumidifier to aid drying
- Use portable fans to move air across the surface
- Because moisture is key to mold issues, treat all signs of condensation and spills seriously and deal with promptly. Failure to deal with a moisture issue promptly may cause more severe issues where none initially existed, or may make a small problem much worse.
- Learn to recognize signs of mold—don’t paint over or cover up suspicious discoloration until you are sure it is not mold. The affected surface must first be cleaned and dried; residual staining may be painted.
- Be sure to understand and eliminate the source of moisture accumulation as a part of the clean-up. Otherwise, the same issues will simply reoccur.
- Small amounts of mold should be cleaned as soon as it appears. Small areas of mold should be cleaned using a detergent/soapy solution or an appropriate RV household cleaner. Gloves should be worn during cleaning. The cleaned area should then be thoroughly dried. Dispose of any sponges or rags used to clean mold.

Tire and Tire Safety Information

This portion of the Owner’s Manual contains tire safety information as required by 49 CFR 575.6. The National Traffic Safety Administration (NHTSA) can be contacted at 1-888-327-4236. Their web site is: <http://www.safercar.gov> and their address is: NHTSA, 400 Seventh St, S.W., Washington, D.C. 20590.

Section One:

The National Traffic Safety (NHTSA) has published a brochure (DOT HS 809 361) that discusses all aspects of Tire Safety, as required by CFR 575.6. This brochure is reproduced in part below. It can be obtained and downloaded from NHTSA, free of charge, from the following web site: http://www.nhtsa.dot.gov/cars/rules/TireSafety/ridesonit/tires_index.html

Studies of tire safety show that maintaining proper tire pressure, observing tire and vehicle load limits (not carrying more weight in your vehicle than your tires or vehicle can safely handle), avoiding road hazards, and inspecting tires for cuts, slashes, and other irregularities are the most important things you can do to avoid tire failure, such as tread separation or blowout and flat tires. These actions, along with other care and maintenance activities, can also:

- Improve vehicle handling
- Help protect you and others from avoidable breakdowns and accidents
- Improve fuel economy
- Increase the life of your tires

This section presents a comprehensive overview of tire safety, including information on the following topics:

- Basic tire maintenance
- Uniform Tire Quality Grading System
- Fundamental characteristics of tires
- Tire safety tips

Use this information to make tire safety a regular part of your vehicle maintenance routine. Recognize that the time you spend is minimal compared with the inconvenience and safety consequences of a flat tire or other tire failure.

Safety First-Basic Tire Maintenance

Properly maintained tires improve the steering, stopping, traction, and load-carrying capability of your vehicle. Under-inflated tires and overloaded vehicles are a major cause of tire failure. Therefore, as mentioned above, to avoid flat tires and other types of tire failure, you should maintain proper tire pressure, observe tire and vehicle load limits, avoid road hazards, and regularly inspect your tires.

Finding Your Vehicle's Recommended Tire Pressure and Load Limits

Tire information placards and vehicle certification labels contain information on tires and load limits. These labels indicate the vehicle manufacturer's information including:

- Recommended tire size
- Recommended tire inflation pressure
- Vehicle capacity weight (VCW—the maximum occupant and cargo weight a vehicle is designed to carry)
- Front and rear gross axle weight ratings (GAWR—the maximum weight the axle systems are designed to carry)

For motor homes: Both placards and certification labels are permanently attached to the vehicle door edge, door post, or glove-box door. You can also find the recommended tire pressure and load limit for your vehicle in the vehicle owner's manual.

Understanding Tire Pressure and Load Limits

Tire inflation pressure is the level of air in the tire that provides it with load-carrying capacity and affects the overall performance of the vehicle. The tire inflation pressure is a number that indicates the amount of air pressure—measured in pounds per square inch (psi)—a tire requires to be properly inflated. (You will also find this number on the vehicle information placard expressed in kilopascals (kPa), which is the metric measure used internationally).

Vehicle manufacturers determine this number based on the vehicle's design load limit, that is, the greatest amount of weight a vehicle can safely carry and the vehicle's tire size. The proper tire pressure for your vehicle is referred to as the "recommended cold inflation pressure." (As you will read below, it is difficult to obtain the recommended tire pressure if your tires are not cold.)

Because tires are designed to be used on more than one type of vehicle, tire manufacturers list the "maximum permissible inflation pressure" on the tire sidewall. This number is the greatest amount of air pressure that should ever be put in the tire under normal driving conditions.

Checking Tire Pressure

It is important to check your vehicle's tire pressure at least once a month for the following reasons:

- Most tires may naturally lose air over time
- Tires can lose air suddenly if you drive over a pothole or other object or if you strike the curb when parking
- With radial tires, it is usually not possible to determine under-inflation by visual inspection

For convenience, purchase a tire pressure gauge to keep in your vehicle. Gauges can be purchased at tire dealerships, auto supply stores, and other retail outlets.

The recommended tire inflation pressure that vehicle manufacturers provide reflects the proper psi when a tire is cold. The term cold does not relate to the outside temperature. Rather, a cold tire is one that has not been driven on for at least three hours. When you drive, your tires get warmer, causing the air pressure within them to increase. Therefore, to get an accurate tire pressure reading, you must measure tire pressure when the tires are cold or compensate for the extra pressure in warm tires.

Steps for Maintaining Proper Tire Pressure

- Step 1: Locate the recommended tire pressure on the vehicle's tire information placard, certification label, or in the owner's manual
- Step 2: Record the tire pressure of all tires
- Step 3: If the tire pressure is too high in any of the tires, slowly release air by gently pressing on the tire valve stem with the edge of your tire gauge until you get to the correct pressure
- Step 4: If the tire pressure is too low, note the difference between the measured tire pressure and correct tire pressure. These "missing" pounds of pressure are what you will need to add
- Step 5: At a service station, add the missing pounds of air pressure to each tire that is under-inflated
- Step 6: Check all the tires to make sure they have the same air pressure (except in cases in which the front and rear tires are supposed to have different amounts of pressure)

If you have been driving your vehicle and think that a tire is under-inflated, fill it to the recommended cold inflation pressure indicated on your vehicle's tire information placard or certification label. While your tire may still be slightly under-inflated due to the extra pounds of pressure in the warm tire, it is safer to drive with air pressure that is slightly lower than the vehicle manufacturer's recommended cold inflation pressure than to drive with a significantly under-inflated tire. Since this is a temporary fix, don't forget to recheck and adjust the tire's pressure when you can obtain a cold reading.

Tire Size

To maintain tire safety, purchase new tires that are the same size as the vehicle's original tires or another size recommended by the manufacturer. Look at the tire information placard, the owner's manual, or the sidewall of the tire you are replacing to find this information. If you have any doubt about the correct size to choose, consult with the tire dealer.

Tire Tread

The tire tread provides the gripping action and traction that prevent your vehicle from slipping or sliding, especially when the road is wet or icy. In general, tires are not safe and should be replaced when the tread

is worn down to 1/16 of an inch. Tires have built-in tread-wear indicators that let you know when it is time to replace your tires. These indicators are raised sections spaced intermittently in the bottom of the tread grooves. When they appear “even” with the outside of the tread, it is time to replace your tires. Another method for checking tread depth is to place a penny in the tread with Lincoln’s head upside down and facing you. If you can see the top of Lincoln’s head, you are ready for new tires.

Tire Balance and Wheel Alignment

To avoid vibration or shaking of the vehicle when a tire rotates, the tire must be properly balanced. This balance is achieved by positioning weights on the wheel to counterbalance heavy spots on the wheel-and-tire assembly. A wheel alignment adjusts the angles of the wheels so that they are positioned correctly relative to the vehicle’s frame. This adjustment maximizes the life of your tires. These adjustments require special equipment and should be performed by a qualified technician.

Tire Rotation

Rotating tires from front to back and from side to side can reduce irregular wear (for vehicles that have tires that are all the same size). Look in your owner’s manual for information on how frequently the tires on your vehicle should be rotated and the best pattern for rotation.

A Tire Rotation Example

For maximum mileage, rotate your tires every 5,000 miles. Follow correct rotation patterns.

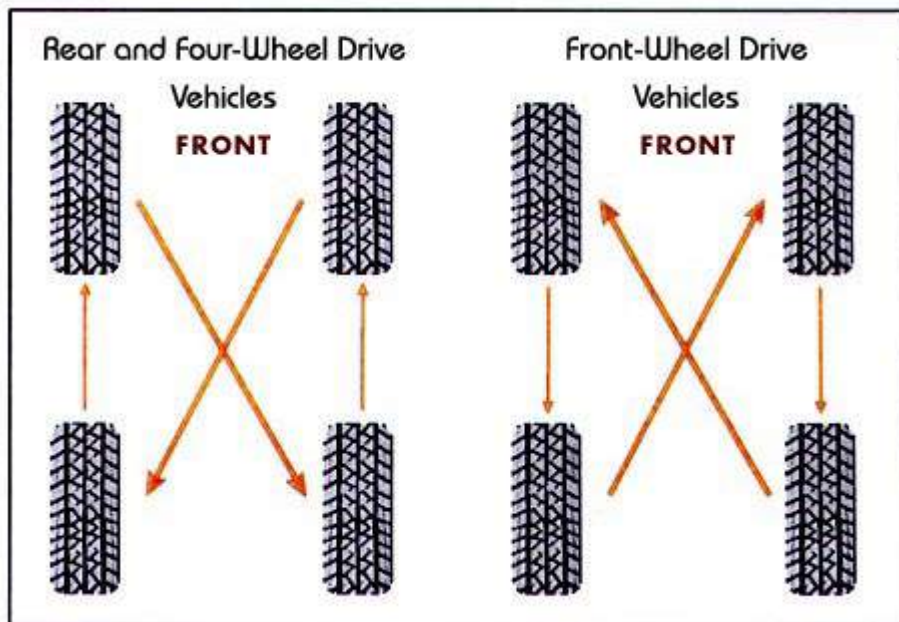

Tire Repair

The proper repair of a punctured tire requires a plug for the hole and a patch for the area inside the tire surrounds the puncture hole. Punctures through the tread can be repaired if they are not too large, but

punctures to the sidewall should not be repaired. Tires must be removed from the rim to be properly inspected before being plugged and patched.

Tire Fundamentals

Federal law requires tire manufacturers to place standardized information on the sidewall of all tires. This information identifies and describes the fundamental characteristics of the tire and also provides a tire identification number for safety standard certification and in case of a recall.

Information on Passenger Vehicle Tires

Please refer to the diagram below.

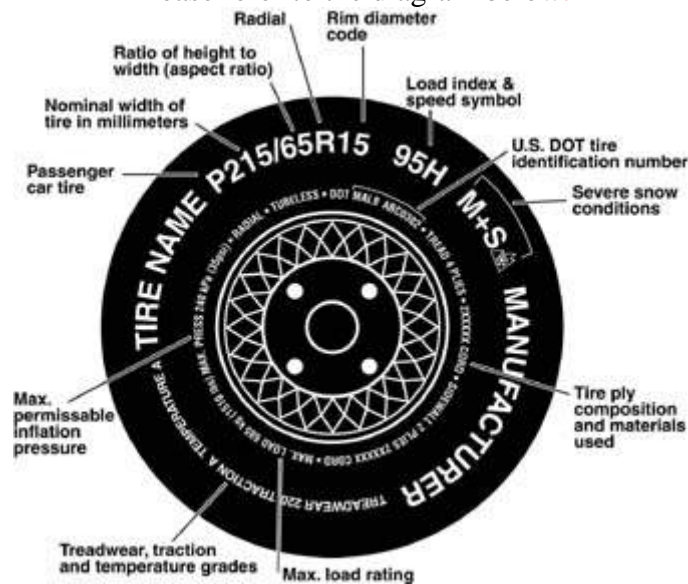

P—The “P” indicates the tire is for passenger vehicles. **NOTE:** Passenger car tires are not recommended for use on trailers, because the capacity ratings are not marked on the side walls of these tires. In the event a passenger car tire is used, the capacity must be de-rated by 10%.

Next number—This three-digit number gives the width in millimeters of the tire from sidewall edge to sidewall edge. In general, the larger the number, the wider the tire.

Next number—This two-digit number, known as the aspect ratio, gives the tire’s ratio of height to width. Numbers of 70 or lower indicate a short sidewall for improved steering response and better overall handling on dry pavement.

R—The “R” stands for radial. Radial ply construction of tires has been the industry standard for the past 20 years.

Next number—This two-digit number is the wheel or rim diameter in inches. If you change your wheel size, you will have to purchase new tires to match the new wheel number.

Next number—This two- or three-digit number is the tire’s load index. It is a measurement of how much weight each tire can support. You may find this information in your owner’s manual. If not, contact a local tire dealer. **NOTE:** You may not find this information on all tires because it is not required by law.

M+S—The “M+S” or “M/S” indicates that the tire has some mud and snow capability. Most radial tires have these markings.

Speed Rating—The speed rating denotes the speed at which a tire is designed to be driven for extended periods of time. The ratings range from 99 miles per hour (mph) to 186 mph. These ratings are listed below. **NOTE:** You may not find this information on all tires because it is not required by law.

Letter Rating	Speed Rating
Q	99 mph
R	106 mph
S	112 mph
T	118 mph
U	124 mph
H	130 mph
V	149 mph
W	168* mph
Y	186* mph

*For tires with a maximum speed capability over 149 mph, tire manufacturers sometimes use the letters ZR. For those with a maximum speed capability over 186 mph, tire manufacturers always use the letters ZR.

U.S. DOT Tire Identification Number—This begins with the letters “DOT” and indicated that the tire meets all federal standards. The next two numbers or letters are the plant code where it was manufactured, and the last four numbers represent the week and year the tire was built. For example, the numbers 3197 means the 31st week of 1997. The other numbers are marketing codes used at the manufacturer’s discretion. This information is used to contact customers if a tire defect requires a recall.

Tire Ply Composition and Materials Used—The number of plies indicates the number of layers of rubber-coated fabric in the tire. In general, the greater the number of plies, the more weight a tire can support. Tire manufacturers also must indicate the materials in the tire, which include steel, nylon, polyester, and others.

Maximum Load Rating—This number indicates the maximum load in kilograms and pounds that can be carried by the tire.

Maximum Permissible Inflation Pressure—This number is the greatest amount of air pressure that should ever be put in the tire under normal driving conditions.

Additional Information on Light Truck Tires

Please refer to diagram below.

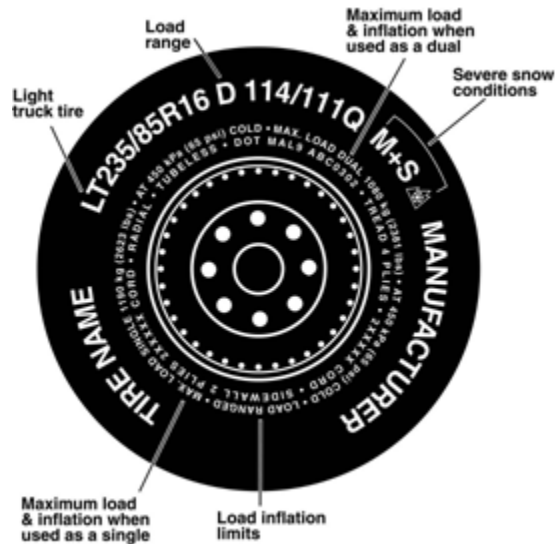

Tires for light trucks have other markings besides those found on the sidewalls of passenger tires.

LT—The “LT” indicates the tire is for light trucks or trailers.

ST—An “ST” is an indication the tire is for trailer use only.

Max. Load Dual kg (lbs) at kPa (psi) Cold—This information indicates the maximum load and tire pressure when the tire is used as a dual; that is, when four tires are put on each rear axle (a total of six or more tires on the vehicle).

Max. Load Single kg (lbs) at kPa (psi) Cold—This information indicates the maximum load and tire pressure when the tire is used as a single.

Load Range—This information identifies the tire’s load-carrying capabilities and its inflation limits.

Vehicle Load Limits

Determining the load limits of a vehicle includes more than understanding the load limits of the tires alone.

On a motor home, there is a Federal certification label that is affixed to either the hinge pillar, door-latch post, or the door edge that meets the door-latch post, next to the driver's seating position. If none of these locations is practicable, this label will be located to the left side of the instrument panel, or affixed to the inward-facing surface of the door next to the driver's seating position.

The certification label will indicate the vehicle's gross vehicle weight rating (GVWR). This is the most weight the fully loaded vehicle can weigh. It will also provide the gross axle weight rating (GAWR). This is the most a particular axle can weigh. If there are multiple axles, the GAWR of each axle will be provided.

For motor homes, in the same location as the certification label described above, there is a vehicle placard. This placard provides tire and loading information. In addition, this placard will show the vehicle's seating capacity for people and a statement regarding maximum cargo capacity.

Cargo Capacities

For motor homes, cargo can be added to the vehicle, up to the maximum weight specified on the placard. For motorized vehicles, the combined weight of passengers and cargo is provided as a single number. If fewer people are traveling, more cargo can be added. If more people are involved, the weight of cargo must be reduced. In any case, remember: the total weight of a fully loaded vehicle, including passengers, can not exceed the stated GVWR.

For motor homes, the water and propane also need to be considered. The weight of fully filled propane containers is considered part of the weight of the RV before it is loaded with people or cargo and is not considered part of the disposable cargo load. Water, however, is a cargo weight and is treated as such. If there is a fresh water storage tank of 100 gallons, this tank when filled would weigh about 800 pounds. If more cargo or people are being transported, water can be off-loaded to keep the total amount of cargo added to the vehicle within the limits of the GVWR so as not to overload the vehicle. Understanding this flexibility will allow you, the owner, to make choices that fit your travel and camping needs.

When loading your cargo, be sure it is distributed evenly to prevent overloading front to back and side to side. Heavy items should be placed low and as close to the axle positions as reasonable. Too many items on one side may overload a tire. The best way to know the actual weight of the vehicle is to weigh it at a public scale. Talk to your RV dealer to discuss the weighing methods needed to capture the various weights related to the RV. This would include weights for the following: axles, wheels, hitch and total weight.

How Overloading Affects Your RV and Tires

The results of overloading can have serious consequences for passenger safety. Too much weight on your vehicle's suspension system can cause spring, shock absorber, or brake failure, handling or steering problems, irregular tire wear, tire failure or other damage.

An overloaded vehicle is hard to drive and hard to stop. In cases of serious overloading, brakes can fail completely, particularly on steep hills. The load a tire will carry safely is a combination of the size of tire, its load range, and corresponding inflation pressure.

Excessive loads and/or under-inflation cause tire overloading and, as a result, abnormal tire flexing occurs. This situation can generate an excessive amount of heat within the tire. Excessive heat may lead to tire failure.

It is the air pressure that enables a tire to support the load, so proper inflation is critical. Since RVs can be configured and loaded in many ways, air pressures must be determined from actual loads (determined by weighing) and taken from the load and inflation tables provided by the tire manufacturer. These air pressures may differ from those found on the certification label. However, they should never exceed the tire limitation for load or air pressure. If you discover that your tires cannot support the actual weights, the load will need to be lightened.

Tire Safety Tips

Preventing Tire Damage

- Slow down if you have to go over a pothole or other object in the road.
- Do not run over curbs or other foreign objects in the roadway, and try not to strike the curb when parking.

Tire Safety Checklist

- Check tire pressure regularly (at least once a month), including the spare.
- Inspect tires for uneven wear patterns on the tread, cracks, foreign objects, or other signs of wear or trauma.
- Remove bits of glass and foreign objects wedged in the tread.
- Make sure your tire valves have valve caps.
- Check tire pressure before going on a long trip.
- Do not overload your vehicle. Check the Tire Information and Loading Placard or User's Manual for the maximum recommended load for the vehicle.

Section Two:

Steps for Determining Correct Load Limit

1. Locate the statement “The combined weight of occupants and cargo should never exceed XXX lbs” on your vehicles placard.
2. Determine the combined weight of the driver and passengers that will be riding in your vehicle.
3. Subtract the combined weight of the driver and passengers from XXX kilograms or XXX pounds.
4. The resulting figure equals the available amount of cargo and luggage capacity. For example, if the “XXX” equals 1400 lbs. and there will be five 150 lb. passengers in your vehicle, the amount of available cargo and luggage capacity is 650 lbs. (1400-750 (5 x 150) = 650 lbs.)
5. Determine the combined weight of luggage and cargo being loaded on the vehicle. That weight may not safely exceed the available cargo and luggage capacity calculated in Step #4.
6. If your vehicle will be towing a trailer, load from your trailer will be transferred to your vehicle. Consult this section to determine how this reduces the available cargo and luggage capacity of your vehicle.

Section Three:

Glossary of Tire Terminology

Accessory weight—The combined weight (in excess of those standard items which may be replaced) of automatic transmission, power steering, power brakes, power windows, power seats, radio and heater, to the extent that these items are available as factory-installed equipment (whether installed or not).

Bead—The part of the tire that is made of steel wires, wrapped or reinforced by ply cords and that is shaped to fit the rim.

Bead separation—This is the breakdown of the bond between components in the bead.

Bias ply tire—A pneumatic tire in which the ply cords that extend to the beads are laid at alternate angles substantially less than 90 degrees to the centerline of the tread.

Carcass—The tire structure, except tread and sidewall rubber which, when inflated, bears the load.

Chunking—The breaking away of pieces of the tread or sidewall.

Cold inflation pressure—The pressure in the tire before you drive.

Cord—The strands forming the plies in the tire.

Cord separation—The parting of cords from adjacent rubber compounds.

Cracking—Any parting within the tread, sidewall, or inner liner of the tire extending to cord material.

CT—A pneumatic tire with an inverted flange tire and rim system in which the rim is designed with rim flanges pointed radially inward and the tire is designed to fit on the underside of the rim in a manner that encloses the rim flanges inside the air cavity of the tire.

Curb weight—The weight of a motor vehicle with standard equipment including the maximum capacity of fuel, oil, and coolant, and, if so equipped, air conditioning and additional weight optional engine.

Extra load tire—A tire designed to operate at higher loads and at higher inflation pressures than the corresponding standard tire.

Groove—The space between two adjacent tread ribs.

Gross Vehicle Weight Rating (GVWR)—The maximum permissible weight of this fully loaded motorhome.

Gross Axle Weight Rating ((GAWR)—The value specified as the load carrying capacity of a single axle system, as measured at the tire-ground interfaces.

Hitch Weight—The vertical trailer load supported by the hitch ball.

Innerliner separation—The parting of the innerliner from cord material in the carcass.

Intended outboard sidewall—The sidewall that contains a white-wall, bears white lettering or bears manufacturer, brand, and /or model name molding that is higher or deeper than the same molding on the other sidewall of the tire or the outward facing sidewall of an asymmetrical tire that has a particular side that must always face outward when mounted on a vehicle.

Light truck (LT) tire—A tire designated by its manufacturer as primarily intended for use on lightweight trucks or multipurpose passenger vehicles.

Load rating—The maximum load that a tire is rated to carry for a given inflation pressure.

Maximum load rating—The load rating for a tire at the maximum permissible inflation pressure for that tire.

Maximum permissible inflation pressure—The maximum cold inflation pressure to which a tire may be inflated.

Maximum loaded vehicle weight—The sum of curb weight, accessory weight, vehicle capacity weight, and production options weight.

Measuring rim—The rim on which a tire is fitted for physical dimension requirements.

Non-pneumatic rim—A mechanical device which, when a non-pneumatic tire assembly incorporates a wheel, supports the tire, and attaches, either integrally or separably, to the wheel center member and upon which the tire is attached.

Non-pneumatic tire assembly—A non-pneumatic tire, alone or in combination with a wheel or wheel center member, which can be mounted on a vehicle.

Normal occupant weight—This means 68 kilograms (150 lbs.) times the number of occupants specified in the second column of Table I of 49 CFR 571.110.

Occupant distribution—The distribution of occupants in a vehicle as specified in the third column of Table I of 49 CFR 571.110.

Open splice—Any parting at any junction of tread, sidewall, or innerliner that extends to cord material.

Outer diameter—The overall diameter of an inflated new tire.

Overall width—The linear distance between the exteriors of the sidewalls of an inflated tire, including elevations due to labeling, decorations, or protective bands or ribs.

Pin Weight—The vertical trailer load supported by the king pin of a fifth wheel hitch.

Ply—A layer of rubber-coated parallel cords.

Ply separation—A parting of rubber compound between adjacent plies.

Pneumatic tire—A mechanical device made of rubber, chemicals, fabric and steel or other materials, that, when mounted on an automotive wheel, provides the traction and contains the gas or fluid that sustains the load.

Production options weight—The combined weight of those installed regular production options weighing over 2.3 kilograms (5 lbs.) in excess of those standard items which they replace, not previously considered in curb weight or accessory weight, including heavy duty brakes, ride levelers, roof rack, heavy duty battery, and special trim.

Radial ply tire—A pneumatic tire in which the ply cords that extend to the beads are laid at substantially 90 degrees to the centerline of the tread.

Recommended inflation pressure—This is the inflation pressure provided by the vehicle manufacturer on the Tire Information label and on the Certification/ VIN tag.

Reinforced tire—A tire designed to operate at higher loads and at higher inflation pressures than the corresponding standard tire.

Rim—A metal support for a tire or a tire and tube assembly upon which the tire beads are seated.

Rim diameter—This means the nominal diameter of the bead seat.

Rim size designation—This means the rim diameter and width.

Rim type designation—This means the industry of manufacturer's designation for a rim by style or code.

Rim width—This means the nominal distance between rim flanges.

Section width—The linear distance between the exteriors of the sidewalls of an inflated tire, excluding elevations due to labeling, decoration, or protective bands.

Sidewall—That portion of a tire between the tread and bead.

Sidewall separation—The parting of the rubber compound from the cord material in the sidewall.

Test rim—The rim on which a tire is fitted for testing, and may be any rim listed as appropriate for use with that tire.

Tread—That portion of a tire that comes into contact with the road.

Tread rib—A tread section running circumferentially around a tire.

Tread separation—Pulling away of the tread from the tire carcass.

Treadwear indicators (TWI)—The projections within the principal grooves designed to give a visual indication of the degrees of wear of the tread.

Vehicle capacity weight—The rated cargo and luggage load plus 68 kilograms (150 lbs.) times the vehicle's designated seating capacity.

Vehicle maximum load on the tire—The load on an individual tire that is determined by distributing to each axle its share of the maximum loaded vehicle weight and dividing by two.

Vehicle normal load on the tire—The load on an individual tire that is determined by distributing to each axle its share of the curb weight, accessory weight, and normal occupant weight (distributed in accordance with Table I of CFR 49 571.110) and dividing by 2.

Weather side—The surface area of the rim not covered by the inflated tire.

Wheel center member—In the case of a non-pneumatic tire assembly incorporating a wheel, a mechanical device which attached, either integrally or separably, to the non-pneumatic rim and provides the connection between the non-pneumatic rim and the vehicle; or, in the case of a non-pneumatic tire assembly not incorporating a wheel, a mechanical device which attaches, either integrally or separably, to the non-pneumatic tire and provides the connection between tire and the vehicle.

Wheel-holding fixture—The fixture used to hold the wheel and tire assembly securely during testing

Tire Pressure

Correct tire inflation pressure is essential to maximizing the life of the tires and assuring the safety of the vehicle and its occupants. Driving with tires that are not correctly inflated for the load of the motor home is dangerous and may cause premature wear, tire damage, and/or loss of control of the motor home.



Figure 14-6. Front Tire

An underinflated tire will build up excessive heat that may actually approach the vulcanization temperature of the rubber and lead to tread separation and/or disintegration of the tire (Figures 14-6,7). Additionally, underinflated tires will also cause poor handling of the motor home, rapid and/or irregular tire wear, and an increase in rolling resistance of the motor home which, in turn, produces a decrease in fuel economy of operation.



Figure 14-7. Rear Tire

An overinflated tire will reduce the tire's "footprint" (i.e., its actual contact with the road); thus, reducing the traction, braking capacity, and handling of the motor home.

A tire that is overinflated for the load that it is carrying will also contribute to a harsh ride, uneven tire wear, and the tire itself will be more susceptible to impact damage.

Maintaining correct tire pressure for each loaded wheel position on the motor home is critically important and must be a part of regular vehicle maintenance.

Tire Maximum Load Rating

Federal law requires that the maximum load rating be molded into the sidewall of the tire. If one looks at a tire sidewall, one may see some "typical" information, such as:

Max. Load Single 3640 Lbs at 85 psi cold

Max. Load Dual 3415 Lbs at 85 psi cold

The maximum load allowed for the size tire and load rating and the minimum cold air-inflation pressure needed to carry that stated maximum load are noted on the tire. Using less air pressure would reduce the load-carrying capacity of the tire.

The amount of air pressure one needs depends on the weight of the fully loaded motor home. Consequently, one cannot determine the correct air-inflation pressure, unless one knows the actual weights of the motor home.

Weighing the Motor Home

Earlier, in Chapter 1, the procedures for weighing the motor home were presented (see pp. 1-7 and 1-8). These procedures provided the weighing of a “nonloaded” (i.e., not stocked with the possessions and provisions the user would normally have onboard for travel) motor home. Obviously, any additional weight stored onboard (inside and underneath) the motor home will contribute to the overall weight of the motor home.

If not stored uniformly throughout the motor home, additional weight of the possessions and provisions of the motor-home user will load each axle and each tire differently (front-to-rear and side-to-side distribution of that additional weight). Accordingly, **it is necessary to weigh the motor home fully loaded as the user would have it for travel, including occupants.** Moreover, **it is necessary to weigh each tire position individually.**

Overloading the motor home can produce problems with the tires, wheels, springs, brakes, drive train, and other motor-home assemblies. In addition, an overloaded motor home uses more fuel, is more difficult to handle properly, and can lead to driver fatigue more quickly. In a worst-case condition, if any component should fail, this could result in loss of control of the motor home and subsequent damage.







In certain states, the Highway Patrol routinely weighs motor homes to check for overloaded axle weights. Therefore, there are many good reasons for assuring that the motor home is properly loaded and not overloaded—this can be accomplished through a proper weighing of the fully loaded motor home.

One can find various places that have certified public scales where one’s motor home can be weighed. For example, moving and storage company lots, farm suppliers with grain elevators, gravel pits, recycling companies, and large-scale commercial-truck stops are some of the possible locations for weighing the motor home. One can also check the Yellow Pages of the telephone book for “scales – public” or “weighers” to determine other locations for weighing the motor home.

A brief overview of the procedure for weighing the motor home is shown in the accompanying figure.

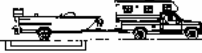
WEIGHING YOUR SINGLE AXLE RECREATIONAL VEHICLE

RV: To Obtain Individual Axle and Gross Vehicle Weights:

	STEP 1a	STEP 1b	STEP 1c	STEP 1d
				
				
Scale Weight	_____ lbs. (Step 1a = GAW)	_____ lbs. (Step 1b = GVW)	_____ lbs. (Step 1c = GAW)	_____ lbs. (Step 1d)
From Owner's Manual	_____ lbs. GAWR	_____ lbs. GVWR	_____ lbs. GAWR	_____ lbs. Vehicle Weight (GCWR - GVW)

To Obtain Individual Wheel Position Weights:

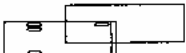
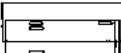
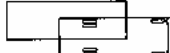
	STEP 2a	STEP 2b	STEP 2c
			
One Side Scale Weight	_____ lbs. (Step 2a)	_____ lbs. (Step 2b)	_____ lbs. (Step 2c)
Calculate Other Side Weight	_____ lbs. (Step 1a-2a)	_____ lbs. (Step 1b-2b)	_____ lbs. (Step 1c-2c)
Tire Load (lbs.)	_____ lbs. (See Note #1)	_____ lbs. (See Note #1)	_____ lbs. (See Notes #1 & 2)
Inflation	_____ psi (See Note #1)	_____ psi (See Note #1)	_____ psi (See Note #1)

Note 1: From the tire manufacturer's load and inflation tables or the sidewall of the tires mounted on the motor home.

Note 2: If the motor home has duals, read dual capacity from the tire D and multiply by 2 (two) to obtain dual-assembly load-carrying capacity.

More detailed information can be found in the manufacturer's literature (Figure 14-8) associated with the chassis and/or the tires provided with the motor home. For example, the following table illustrates the inflation pressures for Michelin tires as a function of the loads per position for a specified speed of the motor home. In this manner, one can determine the appropriate inflation pressures for each of the tires on the motor home, as a function of the loads they are to carry on the trip(s) the motor home is to take. Whenever there is a significant change in the loading regimen of the motor home, it would be wise to re-calculate the load weights of the tires to assure optimal use of the motor home.

INFLATION PRESSURES FOR MICHELIN TIRES

Size/Model	Load Range	Inflation Pressures (PSI)							
		Loads Per Position (in lbs.) at Different Pressures (1 Tire=Single (S) 2 Tires=Dual (D))							
7.50R-16 XPS Rib	D (LRD)	PSI	35	40	45	50	55	60	65
		Lbs.	1620	1770	1920	2060	2190	2310	2440
	F (LRF)	PSI	55	60	65	70	75	80	85
		Lbs.	2475	2650	2815	3040	3230	3405	3640
2.35/70R-19.5 Pilot XZA	F (LRF)	PSI	47	52	57	62	67	72	77
		Lbs.	4760	5120	5510	5820	6170	6560	6930
	G (LRG)	PSI	55	60	65	70	75	80	85
		Lbs.	2475	2615	2755	2895	3040	3195	3315
245/70R-19.5 XRV	F (LRF)	PSI	65	70	75	80	85	90	95
		Lbs.	4140	4440	4740	5040	5340	5640	5940
	G (LRG)	PSI	65	70	75	80	85	90	95
		Lbs.	4140	4440	4740	5040	5340	5640	5940
245/70R-19.5 XRV	G (LRG)	PSI	75	80	85	90	95	100	110
		Lbs.	5190	5460	5740	6040	6340	6640	7140
	H (LRH)	PSI	75	80	85	90	95	100	110
		Lbs.	5190	5460	5740	6040	6340	6640	7140
235/80R-22.5 XRV	G (LRG)	PSI	75	80	85	90	95	100	110
		Lbs.	5190	5460	5740	6040	6340	6640	7140
	H (LRH)	PSI	85	90	95	100	105	110	115
		Lbs.	6190	6540	6890	7240	7590	7940	8290

Figure 14-8. Typical Motor-Home Tire Inflation Pressures

Frequency of Checking Tire Inflation Pressures

When one has determined the “correct” tire inflation pressures for each of the motor-home tires (as a function of the “fully loaded” condition, of course) and inflated the tires under “cold” (i.e., tires haven’t been driven for more than one mile) conditions; then the air pressures in the tires should be periodically checked to make sure that they retain their proper pressures.

It is recommended that tire pressures be checked at least once a month (every two weeks would be better) and before any major trip. On long trips, the tires should be checked every “drive” morning. On short trips (a day or less), the tires should be checked before one departs on the trip and again before one returns home.

Check tire pressures when they are “cold”; that is, the tires haven’t been driven at all or, at most, less than one mile before being measured. In this manner, the tire pressure has not been increased by the heating associated with both tire sidewall and tread flexure associated with traveling. If one must check tires that are warm or hot, remember that they will necessarily read higher than normal.

Do not “bleed” these tires down to the “cold pressure” readings, as they will probably then be underinflated when they are actually cool. Don’t make any adjustments to tire pressures when the tires are warm or hot, if such can be avoided.

To make these tire-pressure measurements, it is recommended that one purchase a quality, truck-tire air gauge which has an angled dual head. This type of gauge allows one to check inflation pressures of both the inner dual wheel which has the valve stem pointing towards one and on the outer wheel which has the valve stem pointing away from one. Pressure-sealing valve caps should always be used to protect the valve stems and prevent air from escaping from the valve stems.

Tire Wear, Balance, and Wheel Alignment

In addition to tire inflation considerations, the tires should also be periodically examined for other types of normal “wear and tear.” If installed and maintained properly, all tires mounted on the motor home should wear in a smooth, even pattern. If the tires begin to show irregular wear patterns and the motor-home alignment is still correct, then sometimes just rotating the tires by changing wheel position and rotation of the tires will allow the tires to wear evenly.

Check with the chassis manufacturer (Ford or Workhorse) and its literature (in the Owner’s Information Package) for particulars on maintaining proper wheel alignment. Tire rotation should include the spare tire (optional on some models) in the rotation pattern and changing the direction of rotation of the tires. Tires can be rotated front-to-rear and side-to-side.

Tire Cleaning

Proper cleaning of the tires will assure maximum years of service. A soft brush and the normal mild soap should be used to clean the tires. Use care in applying any tire “dressing” product as these contain

petroleum derivatives, alcohol, or silicones which may cause deterioration of the rubber, possibly leading to cracking, and accelerate the aging process. In many instances it isn't the actual dressing itself, but the reaction of that product with the antioxidant in the tire. Heat can compound this problem also.

INTERIOR CARE

Important

The fading of upholstery, carpet, and other interior fabrics is generally caused by excessive sunlight. The drapes, blinds, or other shades should be kept closed when the vehicle is parked for an extended period of time to minimize the fading. Normal deterioration of the appearance of such items caused by wear and/or exposure to strong lighting is not covered by the Tiffin Motorhomes Limited Warranty.

Carpet

A weekly routine of vacuuming the carpet and fabrics throughout the vehicle is recommended; the vacuum system (Figure 14-10) has a central connection (Figure 14-9) within the motor home wherein a vacuum hose can be connected and the necessary vacuuming performed, as desired. Doing such will prevent an undue accumulation of dirt which can detract



Figure 14-10.
Vacuum Cleaner
System

from the appearance of the carpeting and, thus, shorten its expected life. Remember to empty or replace vacuum bags before they become overly full—this practice will assure that sufficient vacuuming capability is readily available to handle any and all cleaning situations that may arise. In carpet areas that receive the most sunlight, keeping the curtains closed whenever possible will minimize

fading. Also act quickly when anything is spilled or dropped onto the carpet to prevent or minimize staining.



Figure 14-9.
Vacuum Hose
Coupling

To connect the cleaning hose, raise the wall remote inlet valve door, (Figure 14-9) and align hose end coupling with slots on each side of intake opening. Firmly push into intake opening. Make sure hose end coupling is connected and is locked in place. To disconnect the hose, simply push in the slots on each side of the hose coupling and pull hose end straight out.

To start the vacuum cleaner:

1. Push the on/off switch on the main vacuum to the “on” position. Indicator light in switch will come on. Now the vacuum will come on and off by using the wall remote inlet valve.
2. To turn on, raise the door up.
3. To turn off, lower the inlet valve door down and the vacuum will turn off. The main vacuum on/off switch should stay in the “on” position all the time, except when traveling.
4. To turn completely off, return main vacuum on/off switch to the “off” position. The switch light will go off.

Warning

This appliance has a THERMAL PROTECTOR built in the motor to prevent overheating. If motor will not operate or shuts down while in operation wait 30 minutes; it will reset automatically. Turn unit off while it resets. If the motor does not come on, or Thermal Protector trips off again after a short period, service may be needed. A qualified service technician should perform service.

The vacuum cleaning system comes with an array of attachments that can be connected to the hose ends for extensive cleaning purposes. Make sure they are firmly pushed in and twist to hold in place.

For further instructions to change the dust bag, use the attachments, and proper cleaning technique, refer to the specific Owner’s Manual located in your motor home.

Fabrics

The fabrics (Figure 14-11) used in this Tiffin motor home for the bedspread, draperies, headboard, and valances contain fire-retardant additives that may be damaged by use of improper cleaning products. Cleaning instructions for these items are DRY CLEAN ONLY.

Water-based products are not recommended for cleaning the fabrics in your new vehicle. Most water-based, household-cleaning products are not formulated for use



Figure 14-11. Typical Fabrics in the Bedroom

on these fabrics and may cause excessive shrinkage or fading. For best results, the fabrics in this vehicle should be cleaned by a professional carpet and upholstery cleaner.

Spills, spots, or stains should be treated as soon as possible to avoid permanent damage to the fabrics. If a spill occurs, blot the fluid with a dry towel; do not rub the spill as rubbing may cause the liquid to “set” in the fabric and cause a stain.

When attempting to clean a spot or stain, always start from the outside and work inward to avoid spreading the stain further. Some stains or soils are extremely difficult or impossible to be removed completely. These stains should receive immediate, professional attention. Spills, spots, stains, or soiled areas are the responsibility of the owner and are not covered by Tiffin Motorhomes Limited Warranty.

Warning

When cleaning the upholstery and fabric of the motor home, do not use lacquer thinner, nail polish remover, laundry soaps, or bleach. Never use carbon tetrachloride or gasoline for cleaning purposes. These substances may cause damage to the materials being cleaned and most are high flammable.

Walls and Ceiling

The wall and ceiling coverings should be cleaned periodically to maintain a new appearance. Use a non-abrasive cleaner with a soft cloth on the walls. Do not use solvents of any kind, as those solvents may damage the surfaces being so cleaned.

Dashboard

To keep the dashboard (Figure 14-12) in like-new condition, follow these guidelines:

DO:

- Dust and clean the dashboard with a soft, damp cloth or chamois, wiping the service gently.
- Use a mild detergent and lukewarm water.



Figure 14-12. Dashboard of the Motor Home

- Dry the surface, after washing and rinsing, by blotting with a damp cloth or chamois

DO NOT:

- Use harsh chemicals that may damage the dashboard.
- Use cloths containing grit or abrasive particles or kitchen-scouring compounds to clean or dust the dashboard.
- Subject the dashboard to hard, direct blows.
- Use boiling water, strong solvents, or other such materials to clean the dashboard as they will soften the plastic.

Woodwork & Floors

The wood cabinetry should be cared for with furniture polish to sustain the natural beauty and luster of the wood. This procedure will also keep the cabinetry looking new, prevent the wood from drying, and reduce chances of accidental staining or aging.

Use area rugs and floor mats by the entrance door to trap dirt. Use water and damp mop to clean the laminate flooring, begin by vacuuming the floor to remove loose dust and dirt. Then, damp mop the floor with any standard laminate cleaning solution available through retail sales outlets (e.g., Wal-Mart, Kmart, Target) or grocery stores. The mop should be damp, but not dripping.

To remove candle wax or chewing gum, carefully scrape off when the material has hardened. For further tips, please see the manufacturer’s information sheet in your Tiffin Motorhomes Owners Information Package. Don’t use any abrasives or abrasive cleaners on the laminate flooring.

Countertops

To care properly for the countertops (Figure 14-13) in your new motor home, always use a heat pad or trivet to protect the surface from hot objects that may mar or damage the countertop surface. Hot pans and heat-producing appliances (such as electric skillets), when set directly on top of the countertop, can possibly mar the beauty and finish of the product.

Additionally, since heat-producing appliances can also damage countertop seams, it is essential to check with Tiffin Motorhomes to identify seam locations to avoid them during subsequent use of the motor home. Although surfacing may be repaired, certain steps should be taken to protect it.

Be sure to use a cutting board, rather than cutting directly on the countertop surfaces. Although minor scratches and cuts can be repaired, a little care will assure that the countertop surfaces will keep looking new for years.



Figure 14-13. Countertop in the Kitchen

Avoid using harsh chemicals on the countertop. Wipe the countertop with a damp cloth to remove water spots. For most dirt and stains, wipe with a damp cloth and use soapy water or glass cleaner (e.g., Windex).

Do not expose the surface to harsh chemicals, such as paint remover, turpentine, nail polish remover, or any stove and drain cleansers. If these chemicals should come into contact with the countertop surfaces, immediately wash off these chemicals, using appropriate safety measures to avoid injury.

Accessories

The various metallic light fixtures (Figure 14-14), bath accessories, and faucets can be cleaned by wiping with a soft, damp cloth. Washing with warm water will remove dry water spots.

Do not use cleaners that contain harsh or abrasive chemicals. Alcohol or other similar solvents should never be used.



Figure 14-14. Lighting Fixtures

Detectors

The CO/LP gas detectors are self-contained and DO NOT require any maintenance other than normal cleaning and periodic testing. The smoke detector installed in the motor home is a nine-volt, battery-operated detector. The CO/LP gas detector uses three AA batteries for its operation.

The batteries in the smoke and CO/LP gas detectors need to be tested periodically and replaced when necessary (usually semiannually). When cleaning the case on any of the detectors, use a damp cloth or paper towel. Do not spray cleaners or wax directly into the case as this action may cause false alarms or hinder the normal operation of the detectors.

An inexpensive battery tester, available from any local electronics retailer, would be a good investment to make. This tester would allow checking of the batteries in the various alarms, any flashlights used in the motor home, and batteries in other appliances (e.g., portable radios, MP3 players, CD players, PDAs, and various electronic games) which may be in the motor home during travels.

Condensation

Important

Since surface condensation within the motor home cannot be controlled by the manufacturer, damage caused by condensation is not covered by the Tiffin

Motorhomes Limited Warranty.

Damage may occur to your vehicle if excessive condensation exists. Accumulation of condensation on surfaces within your motor home occurs when warm, moist air contacts a cool surface. It is most evident on the inside of windows, but this problem can be controlled by the following procedure:

1. Slightly open a window or roof vent to allow the moisture to escape from the motor home.
2. Use a small dehumidifier which is also very effective in removing moisture from the air.

Condensation levels are highest during times when a person is cooking or taking a shower in the motor home, but these occasions are not the only times condensation is present. Walls and ceiling panels may become wet when the moisture accumulates on these surfaces. Tiffin Motorhomes does not recommend the use of any catalytic heaters because of resulting extensive condensation.

ROUTINE MAINTENANCE SCHEDULES

Important

Always follow the chassis maintenance guidelines found in the chassis manufacturer's owner's manual.

All routine maintenance is the responsibility of the owner and is not covered by the Tiffin Motorhomes Limited Warranty. Use the maintenance record found in Chapter 15 to record all performed maintenance as required.

Please note that any damage caused by improper or unperformed maintenance is not covered by the Tiffin Motorhomes Limited Warranty. Items supplied by other manufacturers may require specific individual maintenance not listed herein. Please refer to the manufacturers' suggested maintenance guidelines in the Owners Information Package.

Important

Cosmetic adjustments and alignments must be performed within the first three months from date of original purchase for warranty consideration. Thereafter,

these items are considered routine maintenance.

Monthly

- Check the water levels of the batteries.
- Visually inspect the fire extinguisher(s).

Every Three Months

- Check LP gas lines for leaks with soap solution or leak detector.
- Clean the microwave hood exhaust fan filter and blades.
- Test smoke alarm, carbon monoxide detector, and CO/LP gas detector.
- Check operation of windows, latches, and hinges.
- Clean the roof; clean the roof-ducted air conditioner filter or filters.
- Clean and inspect door and window seals; reseal where necessary.
- Inspect and reseal around the tub and shower area where necessary.
- Lubricate the exterior door hinges and latches with a graphite (silicone) lubricant.
- Check, clean, and tighten battery cables and inspect batteries for proper fluid levels.

Every Six Months

- Inspect the slide-out for proper seal. If realignment is necessary, please contact an authorized Tiffin Motorhomes Service Center.
- Inspect all exterior rubber seals; apply a UV inhibitor (e.g., 303 Protectant), as needed.
- Change the battery in the smoke detector.
- Rotate tires as recommended by the tire manufacturer.
- Check all gas appliances for proper operation.
- Have the LP system inspected by a qualified technician.
- Lubricate the movable parts on the entrance step.
- Change the batteries in both the smoke detector and the CO/LP gas detector.

Annually

- Inspection of roof seams and joints should be performed by an authorized Motorhomes Service Center. If resealing is necessary, it is the owner's responsibility and is not covered by the Tiffin Motorhomes Limited Warranty.
- Sanitize the fresh water system.
- Wax and buff all gel-coat surfaces on the vehicle as described previously in this chapter.

Winterizing

To store your vehicle for the winter months, it is necessary to winterize the water system to help prevent freezing of this system. To do this, follow these instructions:

1. Drain all the water from the water system including the holding tank(s), the hot water heater, and the water tank; also drain the *optional* water filter, if installed. For the holding tank(s), open the gate valve(s) to drain the tanks. (NOTE: This procedure is to be performed **only** at a wastewater pumping station to prevent dumping of contaminated water elsewhere). For the hot water heater, remove the outside cover and then remove the drain plug. When this tank is drained, replace the drain plug and then replace the cover. For the water tank, open the green-handled valve to drain the tank; then close the green-handled valve. If an *optional* water filter is installed, remove the filter cartridge and store it in a clean environment (e.g., resealable plastic bag); empty any excess water from the filter housing and replace the housing.
2. Turn the hot water heater by-pass valve located in the water service compartment to the “by-pass” position to prevent filling the water heater tank with antifreeze.
3. Disconnect the inlet connection to the water pump [in the sanitary service compartment under the motor home] (see Figure 14-15). Attach the supplied, vinyl hose (via the plastic coupling on the hose) to the inlet connection and hand-tighten that connection; do not over-tighten.
4. Place the other end of the hose into a gallon of freshwater system antifreeze (one can refer to the local Tiffin Motorhomes dealer or representative for the freshwater antifreeze formulation for your specific area). NOTE: Do not use automotive antifreeze; use only antifreeze approved for RV applications; otherwise, damage to the systems being protected may result.
5. Turn “on” the water pump to start the flow of antifreeze. Turn “on” each faucet, one at a time, and allow pure antifreeze to run through that piping. Let about one cup drop into the drains to protect the traps.
6. When all the antifreeze is withdrawn from the bottle, disconnect the clear vinyl hose from the water-pump inlet connection and reconnect the inlet line to the water pump. (This may require more than one gallon of antifreeze).
7. When the winterizing process is completed, turn the water pump “off” and then reconnect the water line. Store the vinyl hose for future use.



Figure 14-15. Winterizing Process

ROUTINE MAINTENANCE

8. Open the water supply valve that controls flow from the pump to the tank to help prevent freezing on that water line.

Note: Remember, the motor home also has an exterior shower; therefore, this system must be winterized, as well.

If the motor home is equipped an *optional* ice maker and/or an *optional* washer/dryer, the following additional steps should be taken:

Washer/Dryer (optional)

1. With the washer/dryer power in the “off” position, put ½ quart of RV-type antifreeze in the drum; then close the door.
2. Turn the Program Selector knob to “spin.” Then turn the power “on” and let the machine go through the spin cycle for one or two minutes.
3. Turn the power “off” and then unplug the washer/dryer or disconnect the power cord.
4. Shut off both water faucets and then disconnect the water-inlet hoses from the faucets and drain them. This completes the process.

Alternative Washer/Dryer Winterization through the Freshwater System

1. If one is currently pumping antifreeze through the freshwater system, follow these steps to winterize the washer/dryer:
2. With the washer/dryer power “off,” turn the Wash Temperature knob to “Warm.”
3. Turn the Program Selector knob to “Regular Wash” (located in the “Cotton Heavy Duty” section of the knob). Then turn the power “on.”
4. When you see antifreeze in the drum, turn the power “off.” Then advance the Program Selector knob to “Spin.”
5. Turn the power “on” and allow the drum to spin for about 30 seconds.
6. Turn the power “off.” This completes the process.

Depending on whether your particular motor home has a Dometic refrigerator with an *optional* ice maker or not, there are some steps to be taken in winterizing the *optional* ice maker associated with that refrigerator. For the *optional* ice maker, the proper steps to be taken are these:

Dometic Refrigerator Ice Maker (optional)

1. Shut off the water supply to the ice maker.
2. Place a shallow pan under the water solenoid valve.
3. Remove the inlet fitting to the ice-maker water solenoid valve. Then drain the water from the supply line.
4. Remove the plastic nut and water line from the outlet side of the water solenoid valve. Then drain the water from that line. **Note:** Do not lose the metal insert from the plastic water line. One recommended way to secure this insert is to place it into a “zip lock” bag, seal the bag, punch a small hole through the top of the bag above the zip-lock, insert any type of “twist-tie” (i.e., paper-coated, flexible metal wire) through the hole, and then secure that bag to the outlet line for safekeeping.
5. Connect a source of compressed air (up to 20 psig, maximum) onto the inlet fitting of the water solenoid valve. Apply AC power to the solenoid valve for forcing the ice-maker mold assembly through several harvest cycles.
6. Remove the plastic cover from the mold assembly. The bail arm must be in the “down” (or “on”) position.
7. Start the harvest cycle with a flat-blade screwdriver inserted into the center of the small gear.
8. Turn the gear counterclockwise (CCW), when the hold switch closes, the mold assembly will continue to operate through the harvest cycle. During the water-fill sequence of the harvest cycle, the compressed air will blow out the water trapped in the solenoid valve.
9. Repeat the harvest cycle operation (i.e., steps 7 and 8) several times. Note: Damage to the solenoid valve can occur if the AC power is applied for more than 20 seconds.
10. Reconnect and tighten the lines on the water solenoid valve. The metal insert must be installed in the plastic water line going to the outlet side of the water solenoid. Leave the water supply turned “off” until temperatures are above 0° F (-18° C).
11. Dry out the ice-maker mold assembly with a soft cloth. Place the bail arm in the “up” (“off”) position.

De-Winterizing

1. To de-winterize your motor home, open both of the low-point drains to allow the antifreeze solution to drain from the water system.

ROUTINE MAINTENANCE

2. Next, close the low-point drains and connect your motor home to the city water system. Put water in the freshwater tank and pump at least one gallon through the water pump to remove the antifreeze from the water pump. Keep the water heater supply valve closed and the water heater bypass valves open. The supply valve for the freshwater tank from the pump must remain closed.
3. As in winterizing, open the kitchen faucet, bath faucet, inside and outside showers, turning “on” both the hot- and the cold-water valves and flushing the toilet until the antifreeze solution is flushed out of the system and the water flow is clear.
4. Once the system has been flushed, open the water heater supply valve and close the water heater bypass valve. Open the freshwater tank supply valve from the pump and the icemaker valve.
5. Reinstall the *optional* water filter, if used.
6. Be sure to close the fresh water tank drain valves to allow the tank to fill.

Washer/Dryer (Optional)

1. Flush the water pipes.
2. Reconnect the water inlet hoses to the corresponding hot and cold faucets; then turn “on” both water faucets.
3. Plug in the washer/dryer and/or reconnect the power.
4. Run the washer through the “Express” cycle with $\frac{1}{2}$ tablespoon of powder detergent (or liquid equivalent) to clean out the antifreeze. This completes the process.

Maintenance & Data Charts
